

# M9104-AGx-2N Electric Non-Spring-Return Actuators

## Description

The M9104-AGA-2N synchronous motor-driven actuator provides floating (three-wire) control and is easily installed on a VAV box or a small- to medium-sized damper with a round shaft up to 1/2 in. (13 mm) in diameter or a 3/8 in. (10 mm) square shaft. This compact, non-spring-return actuator has a 35 lb-in (4 N-m) running torque and 40 lb-in (4.5 N-m) minimum stall torque in a compact, easy-to-install package. It has a nominal 90-second travel time for 90° of rotation at 60 Hz (108 seconds at 50 Hz) for 90° of rotation.

The M9104-AGS-2N Actuator/Transmitter combines an M9104-AGA-2N with a pre-wired DPT-2015 Differential Pressure Transmitter that has a 0 to 1.5 in. water column (W.C.) (0 to 374 Pa) differential pressure range.

Refer to the *M9104-AGx-2N Electric Non-Spring-Return Actuators Product Bulletin (LIT-2681121)* for important product application information.

## Features

- 30 dBA rating meets audible noise requirements for open ceilings
- synchronous drive provides constant rotation time that is independent of load
- 100,000 cycle rating extends actuator life due to improved technology
- direct shaft mount with single-screw coupler simplifies installation and provides 3-point shaft gripping
- magnetic clutch provides torque protection for the actuator gear train and damper

- adjustable rotation stops allow application versatility with 30 to 90° clockwise (CW) or counterclockwise (CCW) rotation
- manual gear release simplifies setup and field adjustments
- screw terminal connection makes wiring easy

## Applications

The M9104-AGx-2N actuator is used to position balancing, control, round, and zone dampers in typical HVAC applications. It is also used to position the blades in a VAV box.

The actuator mounts directly to the surface of a VAV box, round damper, or small rectangular damper with a single No. 10 self-drilling sheet metal screw (included). There are no additional linkages or couplers required. Clearly labeled electrical terminals simplify installation. Refer to the damper or VAV box manufacturer's information to select the proper timing for the actuator.

When combined with a VAV controller, the actuator provides reliable, integrated damper control. Refer to the *M9104-AGx-2N Series Electric Non-Spring-Return Actuators Application Note (LIT-2681110)* for various configurations with and without the DPT-2015 differential pressure transmitter.

For more information, refer to the *M9104-AGx-2N Electric Non-Spring-Return Actuators Installation Instructions (Part No. 34-636-631)*.



**M9104-AGA-2N  
Electric Non-Spring-Return Actuator**

## Repair Information

If the M9104-AGx-2N Electric Actuator fails to operate within its specifications, replace the unit. For a replacement actuator, contact the nearest Johnson Controls® representative.

## Selection Chart

Code Number	Control Type	Torque / Timing / Voltage	Auxiliary Switches	Comments
M9104-AGA-2N	Floating	35 lb-in (4 N-m) 90 seconds at 60 Hz AC 24 V 50/60 Hz	None	Actuator only
M9104-AGS-2N		35 lb-in (4 N-m) 90 seconds at 60 Hz AC 24 V 50/60 Hz		Actuator includes a DPT-2015 and CBL-2000-1

## Accessories

Code Number	Description
CBL-2000-1	20 in. (0.5 m) wiring harness (Underwriters Laboratories, Inc.® [UL] accepted for plenum use) supplied with the M9104-AGS-2N and may be ordered separately; connects the M9104 and DPT-2015 to the VAV controller
CBL-2000-2	20 in. (0.5 m) plenum rated wiring harness
CBL-2000-3	72 in. (1.8 m) plenum rated wiring harness
DPT-2015-0	0 to 1.5 in. W.C. (0 to 374 Pa) differential pressure transmitter supplied with the M9104-AGS-2N and may be ordered separately
DMPR-KC003	Blade pin extension without bracket supplied with CD-1300 dampers and may be ordered separately

(Continued)

Dimensions

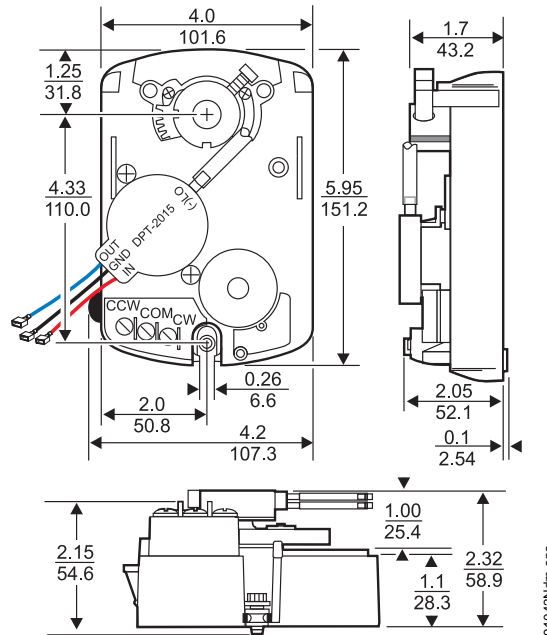

Note: All dimensions are nominal unless otherwise specified.

Dimensions, in. (mm)

Technical Specifications

M9104-AGx-2N Electric Non-Spring-Return Actuators		
<b>Power Requirements</b>	M9104-AGx-2N: 20 to 30 VAC at 50 or 60 Hz, 2.1 VA maximum, Class 2 DPT-2015: 15 VDC (14.5 to 17 VDC, unregulated); 15 mA maximum	
<b>Input Signal</b>	M9104-AGx-2N: 24 VAC (20 to 30 VAC) at 50 or 60 Hz	
<b>Motor Input Impedance</b>	M9104-AGx-2N: 250 ohms, nominal	
<b>DPT-2015-0</b>	Pressure range: 0 to 1.5 in. W.C. (0 to 374 Pa) Over pressure limit: 15 in. W.C. (3.74 kPa) Output voltage: 0.5 to 4.5 VDC with 25,000 ohm minimum load impedance	
<b>Audible Noise Rating</b>	30 dBA maximum at 1 m	
<b>Mechanical Output</b>	Running torque: 35 lb-in (4 N-m)	
<b>Rotation Range</b>	Adjustable from 30 to 90°, CW or CCW	
<b>Rotation Time</b>	Nominal 90 seconds at 60 Hz for 90°; nominal 108 seconds at 50 Hz for 90°	
<b>Cycles</b>	100,000 full cycles, 2,500,000 repositions rated at 35 lb-in (4 N-m)	
<b>Electrical Connection</b>	No. 6-32 screw terminals on the M9104 actuator; 1/4 in. spade terminals on the DPT-2015	
<b>Pressure Connection</b>	6 in. (152 mm) length of silicone tubing with barbed fittings for 1/4 in. (6.35 mm) O.D. tubing	
<b>Enclosure</b>	NEMA 1, IP30	
<b>Ambient Operating Conditions</b>	M9104-AGA-2N: 32 to 125°F (0 to 52°C); 90% RH maximum, noncondensing M9104-AGS-2N: 32 to 125°F (0 to 52°C); 90% RH maximum, noncondensing 60 to 100°F (16 to 38°C); 90% RH maximum, noncondensing for DPT rated accuracy (Refer to the <i>DPT-2015 Differential Pressure Transmitter for VAV Box Applications Installation Instructions</i> [Part No. 24-7547-18].)	
<b>Ambient Storage Conditions</b>	-20 to 150°F (-29 to 66°C); 90% RH maximum, noncondensing	
<b>Dimensions (H x W x D)</b>	M9104-AGA-2N: 5.95 x 4.2 x 2.15 in. (151.2 x 107.3 x 54.6 mm) M9104-AGS-2N: 5.95 x 4.2 x 2.32 in. (151.2 x 107.3 x 58.9 mm) with the DPT-2015	
<b>Shipping Weight</b>	M9104-AGA-2N: 2.0 lb (0.91 kg) M9104-AGS-2N: 2.2 lb (0.99 kg) with the DPT-2015	
<b>Compliance</b>	<b>United States</b>	UL 873 Listed, File E27734, CCN XAPX
	<b>Canada</b>	CSA Certified C22.2 No. 139, File LR85083, Class 3221 02
	<b>Europe</b>	CE Mark - Johnson Controls declares that this product is in compliance with the essential requirements and other relevant provisions of the EMC Directive 2004/108/EC.