

UNIQUE[®]

OFF-GRID APPLIANCES

UGP-24 CT1
23.25" (59.1 cm)

UGP-30 CT1
30" (76.2 cm)

UGP-36 CT1
35.5" (90.2 cm)

**ON-GRID/OFF GRID
GAS COOKTOP** (LPG & NG convertible)

**INSTALLATION
AND OWNERS MANUAL**



READ AND SAVE THESE INSTRUCTIONS

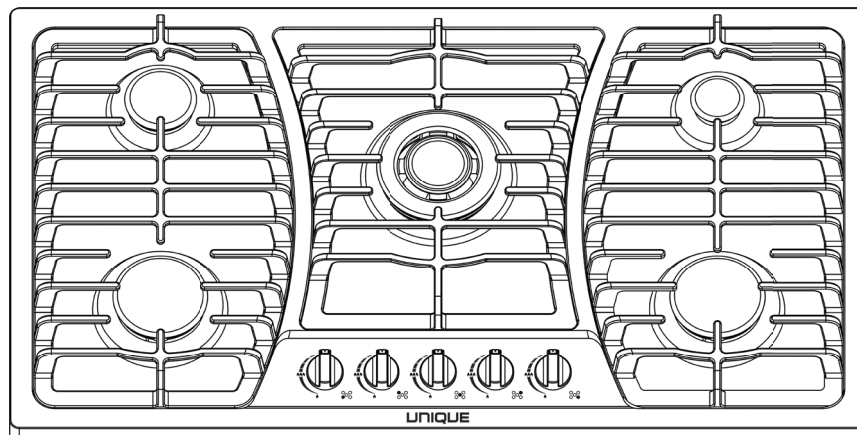
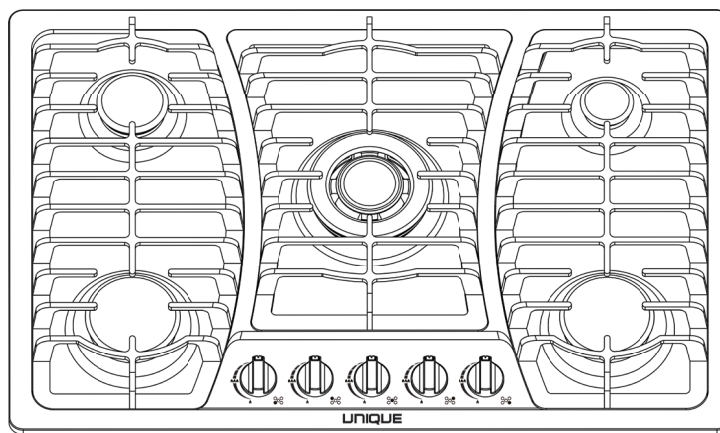
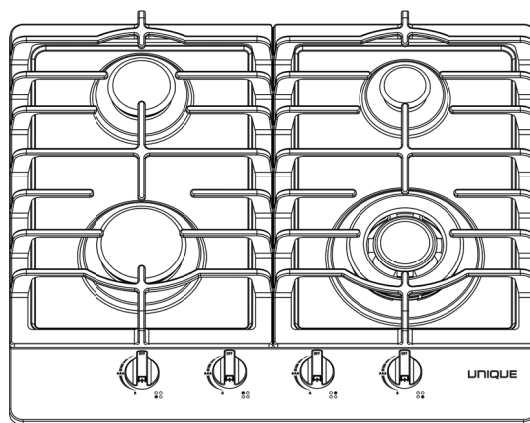

UNIQUE 24CT/30CT/36CT MODELS

ON/OFF GRID GAS COOKTOP – LPG & NG CONVERTIBLE

Installation and Owners Manual

This manual contains information for:

- Important Safeguards
- Installation
- Use and Care

Certain cooktops come equipped with special features. Determine from a study of your cooktop which of the instructions given in this booklet pertain to your cooktop. This booklet gives valuable instructions covering the installation and adjustment and use of your cooktop.

How to Obtain Service and/or Parts

When your cooktop does not operate in accordance with the instructions in the manual, you should contact the dealer in your immediate vicinity for service. Or, the purchaser may contact the service organization noted on the warranty.

Important

TO THE OWNER OF THE COOKTOP: Retain this owners manual for future reference.

TO THE INSTALLER: Leave this owner's manual with the cooktop.

Read and Save These Instructions



The installation of the appliance must conform with local codes ANSI Z21.1a-2010, in the absence of local national Fuel Gas Code, ANSI Z233.1, and in Canada B149.2 Propane Storage and Handling Code





MANUFACTURED AND CERTIFIED BY

Unique Gas Products Ltd

WARNING: If the information in this manual is not followed exactly, a fire or explosion may result causing property damage, personal injury or death.

- Do not store or use gasoline or other flammable vapors and liquids in the vicinity of this or any other appliance.
- **WHAT TO DO IF YOU SMELL GAS**
 - Do not try to light any appliance.
 - Do not touch any electrical switch.
 - Do not use any phone in your building.
 - Immediately call your gas supplier from a neighbor's phone. Follow the gas supplier's instructions.
 - If you cannot reach your gas supplier, call the fire department.
- Installation and service must be performed by a qualified installer, service agency or the gas supplier.

2245 Wyecroft Road #5
Oakville, Ontario Canada L6L 5L7
Ph: 905-827-6154 Toll Free: 1-877-427-2266 Fax: 905-827-2027
www.UniqueOffGrid.com

Table of Contents

Contents

Important Safeguards	Page 1 - 5
Energy Saving Ideas	Page 6
Installation Instructions	Page 7-8
Wall Clearances	Page 9
Alignments and Adjustments	Page 10 - 14
Operation of Cooktop	Page 15 - 16
Cleaning the Cooktop	Page 17
How to Gain Access to the Battery	Page 18
Gas Cooktop Conversion and Adjustment Guide	Page 19-21
Wiring Diagram	Page 22-24
Parts Lists	Page 25-33
Warranty	Page 34

Note: For warranty and service information, please see attachments packaged with cooktop.

Welcome & Congratulations

Congratulations on your purchase of a UNIQUE cooktop! We are very proud of our products and are completely committed to providing you with the best service possible. Your satisfaction is our #1 priority. Please read this manual very carefully, it contains valuable information on how to properly maintain your new gas cooktop.

Thank You for choosing one of our Unique appliances - we hope you will consider Unique for future purchases.

PLEASE READ AND SAVE THESE INSTRUCTIONS

This manual provides specific operation instructions for your model. Use your cooktop only as instructed in this manual. These instructions are not meant to cover every possible condition and situation that may occur. Common sense and caution must be practiced when installing, operating and maintaining the appliance

Record in the space provided below the Model No. and Serial No. of this appliance. These numbers are found on the serial plate located underneath the cooktop.

Model No. _____ Type Number _____

Serial No. _____ Purchase Date _____

Record these numbers for future use.

IMPORTANT: Keep a copy of your bill of sale. The date on the bill establishes the warranty period should service be required. If service is performed, it is in your best interest to obtain and keep all receipts.

PLEASE DO THIS NOW!

The **PRODUCT REGISTRATION CARD** should be filled in completely, signed and returned. This information will register your product and help us to serve you quickly in the future if necessary.



READ ALL IMPORTANT SAFEGUARDS AND ALL INSTRUCTIONS BEFORE USING THE APPLIANCE.

If you smell gas

- Open windows
- Don't touch electrical switches
- Extinguish any open flame
- Immediately call your gas supplier



FOR YOUR SAFETY

- Keep appliance area clear and free from combustible materials, gasoline and other flammable vapors and liquids.

Warnings

Destroy the carton and plastic bags after the cooktop is unpacked. Children should not use packaging material for play, cartons covered with rugs, bedspreads, or plastic sheets can become air-tight chambers. Remove all staples from the carton. Staples can cause severe cuts and destroy finishes if they come in contact with other appliances or furniture.

Be safety conscious. The preparation of food on a cooktop requires temperatures that could cause severe burns. Before using this new appliance, carefully read and follow all instructions.



The California Safe Drinking Water and Toxic Enforcement Act of 1986 (Proposition 65) requires the Governor of California to publish a list of substances known to the State of California to cause cancer or reproductive harm. In addition, businesses must warn customers of potential exposure to such substances.

Users of this appliance are hereby warned that the burning of gas can result in low level exposure to some of the listed substances, including formaldehyde, benzene, soot and carbon monoxide. This is caused primarily from the incomplete combustion of natural gas or LP fuel. Properly adjusted burners will minimize incomplete combustion. Exposure to these substances can also be minimized by properly venting the burners by opening a window or using a ventilating hood or fan.

Do not use water or flour on grease fires. Smother the fire with a pan lid, baking soda or use a dry chemical or foam-type extinguisher.

Operation of the Surface Burners. When the burners are operated for the first time, a small amount of smoke may be generated due to tape residue or manufacturing lubrication. **THIS IS NOT DANGEROUS.** Operate the burners for about five minutes to rid the burners of this material before cooking.

Use only dry potholders. Wet or damp potholders on hot surfaces can result in burns from steam. Do not let the potholder touch hot heating areas. Do not use a towel or other bulky cloth instead of a potholder.

Use proper flame size. Adjust flame size that so it does not extend beyond the edge of the utensil. The use of undersized cookware will expose a portion of the burner flame and may result in severe burns or direct contact and ignition of clothing. Also, proper relationship of utensil to burner will improve efficiency.

Know which knob controls each burner. Place a pan of food on the burner before turning it on, and turn the burner off before removing the pan. Always turn to the full LITE position ⚡ when igniting top burners. Then adjust the flame size so it does not extend beyond the edge of the utensil.

Utensil handles should be turned inward and not extend over adjacent surface burners. To reduce the risk of burns, ignition of flammable materials, and spillage due to unintentional contact with the utensil, the handle of a utensil should be positioned so that it is turned inward, and does not extend over adjacent surface burners.

Never leave the surface burners unattended. Boilovers can leave greasy spills that can create excess smoke or a fire hazard, and cookware that has boiled dry may warp or melt.

Allow parts to cool to room temperature before touching or removing them from the cooktop. When a surface burner is first turned off, the burner and grate are hot enough to cause burns.

Clean the cooktop regularly to keep all parts clean of grease or residue which could catch fire. Pay particular attention to the area underneath each surface burner. Do not allow fat or grease to accumulate. If a hood has been installed for use with the cooktop, ensure that it is kept clean and in good working order. Greasy deposits in the fan could catch fire. Refer to the hood manufacturer's instructions for cleaning.

Do not use a "cyclonic" cooktop hood with this product. Some cooktop hoods circulate air by blowing downward toward the cooktop then drawing the air back up into the hood. This creates a "cyclonic" air wash that is designed for electric cooktops only. A "cyclonic" hood may cause the burners of a gas cooktop to operate improperly.

Glazed cooking utensils: Only certain types of glass, glass/ceramic, ceramic, earthenware, or other glazed utensils are suitable for cooking due to the sudden change in temperature. Check the manufacturer's recommendations for cooktop use.

Do not place plastic salt and pepper shakers, spoon holders or plastic wrappings on top of the cooktop. These items could melt or ignite. Potholders, towels or wooden spoons could catch fire if placed too close to the flame.

Do not use a wok equipped with a metal ring that extends beyond the burner. Because this ring traps heat, the burner and grate could be damaged. Also, the burner may not work properly, creating a carbon monoxide level above current health standards.

Flexible Connectors: If the gas cooktop is connected to a gas supply with a metal flexible connector, disconnect the cooktop with CAUTION for service or cleaning.

Flexible connectors are not intended for repeated bending. Do not allow cleaners to make contact with flexible connectors.

The connector and its fittings are designed for use only on the original installation and are not to be reused for another appliance or at another location. Connectors must comply with ANSI Z21.24.

It is good practice for each household to have an appropriate fire extinguisher for use in the event of a house fire.

Disconnect the cooktop from electrical supply if connected before attempting to service or move it.

NOTE: The instructions appearing in this owner's guide are not meant to cover every possible condition and situation that may occur. Common sense and caution must be practiced when operating and maintaining any appliance.

 **WARNING** On sealed burner models never attempt to operate the surface burners without the cooktop, burner caps, and ignition wires firmly in place. There is a risk of fire and/or explosion which could result in personal injury or property loss.

ENERGY-SAVING IDEAS

Surface Cooking

Use lids when surface cooking. A lid traps steam and uses it to speed up the cooking process. If you have a pressure cooker or vegetable steamer, use it. You'll waste fewer vitamins, save time and cut energy costs.

Use medium-weight, flat bottomed pans that match the flame size. Choose pans made of metals that conduct heat well.

Installation Instructions

Be sure the cooktop is properly installed and grounded by a qualified technician. It is the responsibility of the technician to make certain that your cooktop is properly installed. Situations cause by improper installation are not covered under the warranty. Any expenses incurred due to such situations will not be paid by the manufacturer of the cooktop.

GAS CONNECTIONS (All Units)

NOTICE TO MASSACHUSETTS APPLIANCE DEALERS:

Be sure this document is included in all gas cooktop appliances sold to consumers in the State of Massachusetts.

NOTICE: Massachusetts law requires the following:

- Appliances must be installed by a licensed plumber or gas fitter.
- Appliances must be connected with a three (3) foot (36" maximum length) flexible gas connector and
- A "T" handle type manual gas valve in the gas supply line to the appliance.

Have the dealer where you purchase your new cooktop install it or have them recommend a qualified installer. Installation must conform with local codes. In the absence of local codes, the installation must conform with the National Fuel Gas Code, ANSI Z223.1-Latest Edition in the U.S.A. or the CAN/CGA B149.1 or .2 Installation Codes in Canada.

The cooktop should be connected to the supply line with 1/2-inch black iron pipe or a certified flexible type stove connector. To prevent gas leaks, put an approved sealing compound which is resistant to liquefied petroleum gases on all threaded connections.

Important: Do not apply pressure directly to the cooktop manifold pipe when tightening supply connections. The manifold pipe should be held securely at the pressure regulator to prevent twisting. Hold the pressure regulator with a wrench during the tightening of the connection, or the manifold pipe may be twisted and split and cause a dangerous leak.

The installation of cooktops designed for manufactured (mobile) home installation must conform with the Manufactured Construction and Safety, Title 24 CFR, Part 3280, [formerly the Federal standard for Mobile Home Construction and Safety, Title 24, HUD (Part 280)] in the U.S.A. or C.S.A. Standard CAN/CGA Z240.4.2 in Canada or, when such standards are not applicable, with local codes.

The installation of cooktops designed for recreational vehicle installation must conform with state or other codes or, in the absence of such codes, with the standard for recreational vehicles. ANSI A119.2.2-1982 in the U.S.A. or CAN/CGA Z240.4.2 in Canada.

The installation of appliances designed for recreational park trailers must conform with state or other codes or, in the absence of such codes, with the standard for recreational park trailers, ANSI A119.5.

Note: Check all piping connections in the unit for leaks. Never use an open flame to check for gas leaks. Use a soap solution, 75% water, 25% dish washing soap. It is possible for connections made at the factory to leak, due to vibration encountered in transportation. Make certain you have checked them all, and repair any connections that leak.

The appliance and its individual shut-off valve must be disconnected from the gas supply piping system during any pressure testing of that system at test pressures in excess of 1/2 psig.

The appliance must be isolated from the gas supply piping system by closing its individual manual shut-off valve during any pressure testing of the gas supply piping system at test pressures equal to or less than 1/2 psig.

TOOLS YOU WILL NEED

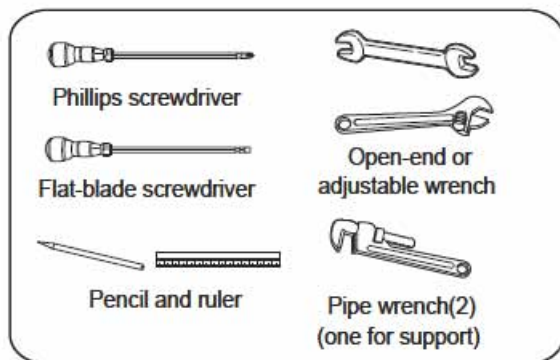

MATERIALS YOU MAY NEED

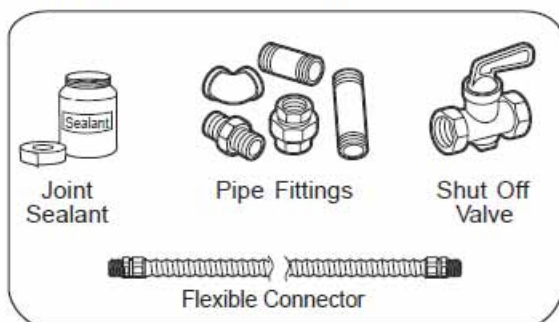

- Gas line shut-off valve
To reduce the possibility of gas leaks, apply Teflon tape or a thread compound approved for use with LP or Natural gases to all threaded connections.
- A flexible metal appliance connector (5/8" I.D., 3-foot length)
Recommended for ease of installation but other lengths are acceptable. Never use an old connector when installing a new cooktop.
- Liquid leak detector or soapy water, 75% water, 25% dish washing soap.

CLEARANCES

Minimum Clearances

- From rear wall to back edge of cooktop: 3"/7.6 cm for the 24" model and 2.5"/6.4 cm for the 30" & 36" Unique models.
- Front edge of cooktop to front edge of vertical face of cabinets – 1.5"/3.8 cm for the 24" model and 2"/5.1 cm for the 30" & 36" Unique models.
- Left side to edge of cooktop: 36"/91.4 cm.
- Right side to edge of cooktop: 8"/20.3 cm.
- Vertical clearance: 30"/76.2 cm.

All units must be installed in accordance to minimum rear and side wall clearances and clearances extended vertically above cooking top which are stated on the serial plate (the serial plate is located underneath the cooktop.)

Make sure that the wall coverings, countertops and cabinets around the cooktop can withstand temperatures of up to 200° F/93° C generated by the cooktop.

If a range hood is installed above the cooktop, maintain a 30" (76.2 cm) minimum clearance between the cooktop and the bottom of the range hood. The range hood must exhaust outside.

A range hood with a minimum 350 CFM that projects at least 5" (12.7 cm) beyond the front edge of cabinets can reduce the risk of burns caused by reaching over heated surface units.

Do not install with a downdraft ventilation system.

If a 30"/76.2 cm clearance between cooking surface and overhead combustible material or metal cabinets cannot be maintained, protect the underside of the cabinets above the cooktop with not less than 1/4"/0.64 cm insulating millboard covered with sheet metal not less than 0.0122"/0.03 cm thick. Clearance between the cooking surface and protected cabinets **MUST NEVER BE LESS THAN 24 INCHES/61 CM.**

IN THE EVENT OVERHEAD CABINETS ARE INSTALLED, THE MAXIMUM DEPTH OF CABINETS INSTALLED ABOVE COOKING TOPS SHOULD BE 30"/76.2 CM.

The vertical distance from the plane of the cooking surface to the bottom of adjacent overhead cabinets extending closer than 1"/2.5 cm to the plane of the cooktop sides must not be less than 18"/45.8 cms.

ALIGNMENTS AND ADJUSTMENTS

Installation

It is the responsibility of the installer to make certain that the cooktop is properly adjusted at the time of installation. Situations caused by improper adjustments or improper installation are not covered under the warranty. Any expenses incurred due to such situations will not be paid by the manufacturer of the appliance.

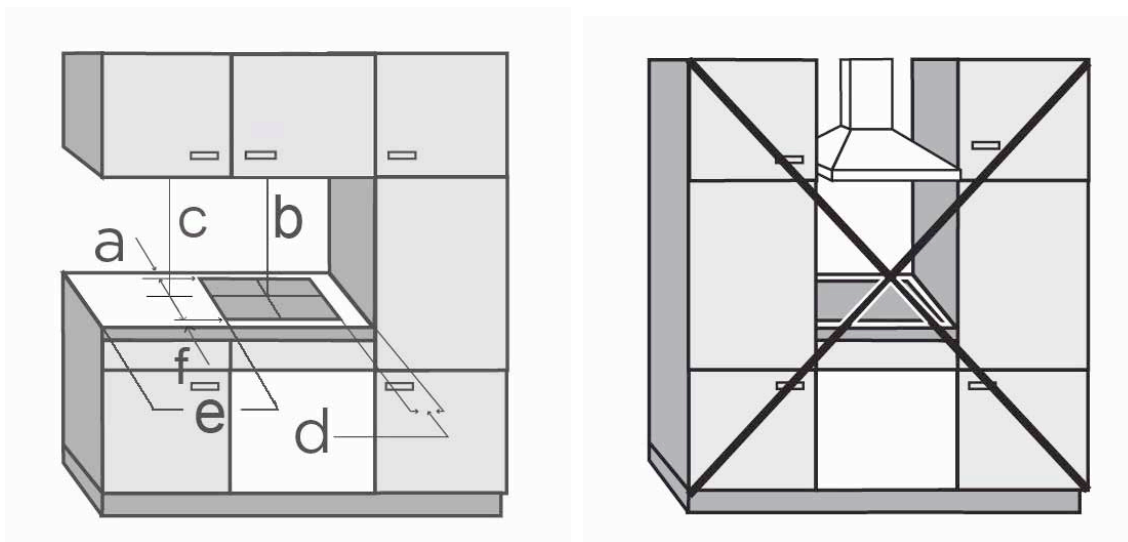

Clearances						
Model	A – to back wall	B – above cooktop	C – side and above countertop	D – to any side wall	E - to left or right of cooktop adjacent opposite wall	F – to front of countertop/front vertical face of overhead countertop
24 CT	3"/7.6 cm	30"/76.2 cm	18"/45.7 cm	8"/20.3 cm	36"/91.4 cm	1.5"/3.8 cm
30 CT	3"/7.6 cm	30"/76.2 cm	18"/45.7 cm	8"/20.3 cm	36"/91.4 cm	2"/5.1 cm
36 CT	3"/7.6 cm	30"/76.2 cm	18"/45.7 cm	8"/20.3 cm	36"/91.4 cm	2"/5.1 cm

Cut Out Details

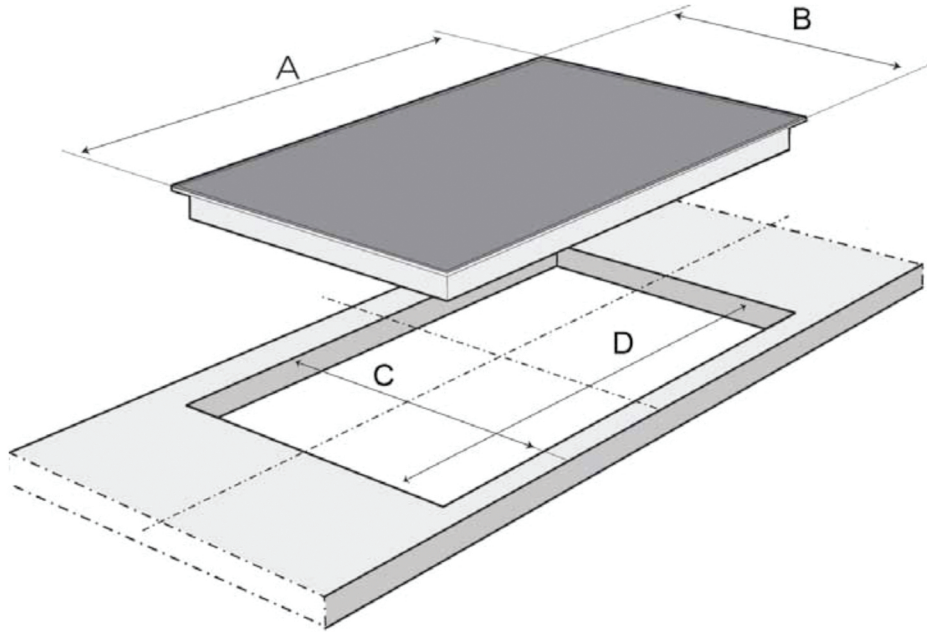

	Dimensions			
Model	A – Width of cooktop	B – depth of cooktop	C – depth of cooktop base	D – Width of cooktop base
24 CT	59 cm/23.2”	51 cm/20.1”	46.3 cm/18.2”	54.8 cm/21.6”
30 CT	76 cm/29.9”	51 cm/20.1”	46.3 cm/18.5”	71.9 cm/28.3”
36 CT	90 cm/35.4”	51 cm/20.1”	46.3 cm/18.2”	85.8 cm/33.8”

- Make the countertop cut-out following the dimensions given in the illustration above pertaining to each model size. Use template provided to ensure an accurate cut.
- Remember to maintain a minimum stated distance between the rear wall and the back of the cooktop.
- If cabinets are located above the cooktop, allow a minimum clearance of 30”/76.2 cm between the cooking surface and the bottom of unprotected cabinets.
- Seal the cut surfaces with a suitable heat-resistant sealant to avoid swelling caused by moisture.

- If during installation the seal around the frame does not sit flush within the countertop at the corners, the corner radius (maximum 3/16" (4 mm)) can be carefully filed down to fit. The cooktop has a seal underneath to keep it securely in position and water/debris from getting underneath cooktop base.
- Use the clips that are included to hold the base securely in place.

Installing the cooktop

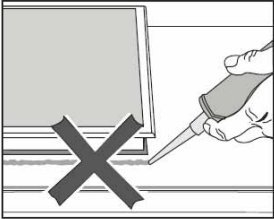
- Remove the cooktop from its package and set aside all burners, burner caps and grates.
- Before placing the cooktop into the cut-out, flip the cooktop upside down and install the gasket provided. Then flip the cooktop back over and lower it centrally into the cut-out. When doing so, make sure that the seal under the cooktop sits flush with the countertop on all sides. This is important to ensure an effective seal. Do not use sealant. 

- Use the 4 supplied clips to secure the base with the underside of the countertop.
- Take each clip and slide it into each slot on the cooktop base, then loosely fasten the clips to the cooktop with a Philips screwdriver with the screws provided. Once this is done you're now ready to secure the cooktop to the underside of the cabinet.

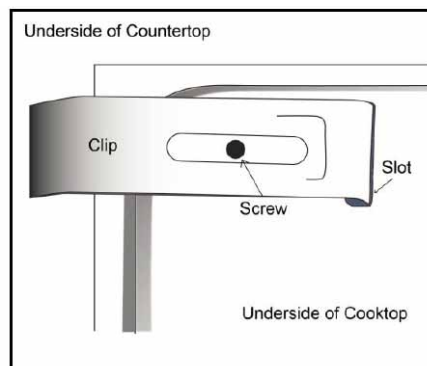

- Tighten the cooktop to the underside of the counter until secure.

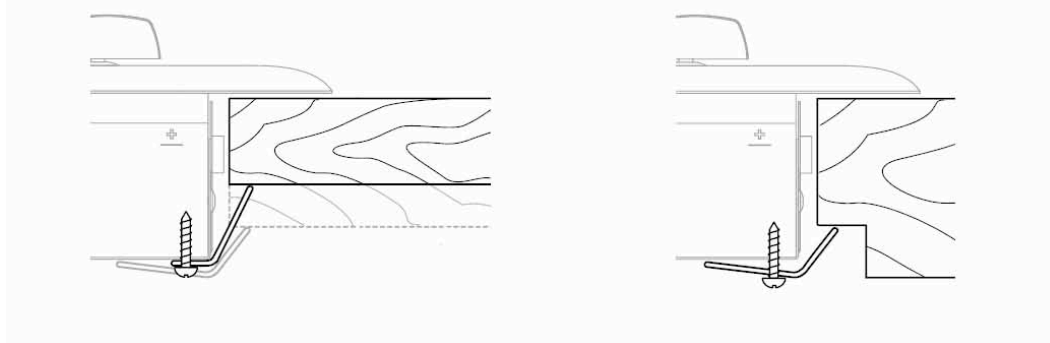

- Install all burners and burner caps
- Install all grates. Please be aware of the grate positioning on some models - the holes in the grates must align over top of the burners.

Connecting gas to cooktop

This cooktop is designed to operate at a pressure of 4" of water column on natural gas or 10" of water column on propane gas (LPG).

Make sure you are supplying your cooktop with the type of gas for which it is designed. It's shipped for use with LPG. This cooktop is convertible for use on natural gas (NG) also. When using this cooktop on NG gas, conversion must be made by a qualified NG installer before attempting to operate the cooktop on that gas.

For correct operation, the pressure of natural gas supplied to the regulator should be between 4" and 5" of water column. For LP gas, the pressure supplied must be between 10" and 12" of water column.

When checking for correct operation of the regulator, the inlet pressure must be at least 1" more than the operating manifold pressure as given above.

The pressure regulator located at the inlet of the cooktop manifold must remain in the supply line regardless of whether natural or LP gas is being used.

Regulator is only good for ½ psi (14" w.c.) so test pressure must not exceed ½" psi.

A flexible metal appliance connector used to connect the cooktop to the gas supply line must have an internal diameter of 5/8" / 1.6 cm and should be 3 feet / 91.4 cm max. in length for easy installation. In Canada, flexible connectors should be single wall metal connectors less than 6 feet / 182.9 cm in length.

Shut off the main gas supply valve before removing the old cooktop and leave it off until the new hook-up has been completed. Don't forget to relight the pilots on other gas appliances when you turn the gas back on.

Because hard piping restricts movement of the cooktop, the use of a CSA certified flexible metal appliance connector is recommended unless local codes require a hard-piped connection. Never reuse an old connector when installing a new cooktop. If the hard piping method is used, you must carefully align the pipe; the cooktop cannot be moved after the connection is made.

To prevent gas leaks, use pipe joint compound resistant to L.P. gases on all male external pipe threads.

1. In an easily accessible location, install a service manual gas shut off valve. Be sure everyone operating the cooktop knows where and how to shut off the gas supply to the cook top.
2. Use a flexible gas line to connect to the 1/2" fitting, located on the bottom of the cook top
3. When all connections have been made, be sure all cooktop controls are in the off position and turn on the main gas supply valve. Check for gas leaks by using a 75% water, 25% dish washing soap solution. If a gas leak is present, shut off gas immediately, tighten all connections, and retest for leaks.
4. Any opening in the wall behind the appliance and in the floor under the appliance shall be sealed.

Correct Flame Appearance

Incorrect: flame lifting off the burner

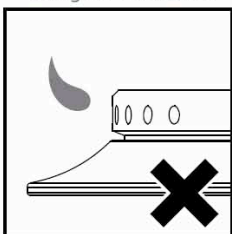

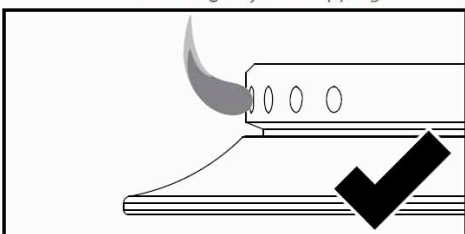

Good flame: well-defined blue flame with slight yellow tipping



Incorrect and good flame patterns

QUALITY OF FLAMES

The combustion quality of burner flames needs to be confirmed visually.

	A Yellow flames — Call for service
	B Yellow tips on outer cones — It is normal for LP gas
	C Soft blue flames — It is normal for natural gas

If burner flames look like A, call for service. B or C is normal burner flames, depending on the type of gas you use. With LP gas, some yellow tipping on outer cones is normal.

OPERATION OF COOKTOP

Top Burner Operation

Note: When boiling food, the highest temperature that can be reached is the boiling point. When the liquid starts to boil, decrease the size of the flame until you reach the minimum flame that will hold the boil. This will save gas. It will also lessen the possibility of burning food or boil overs, and help to keep your kitchen cooler. Use stable cookware with flat bottoms and always place the cookware on the burner grate before lighting the burner. Unstable or rounded bottom cookware will not contact properly with the grate and will affect the cooking efficiency. Select cookware large enough to avoid spillovers. Over-sized cookware (diameters exceeding 8 1/2") can cause the cooktop finish to discolor, craze or chip. Damage caused by oversized cookware, such as those sometimes used in canning, are not covered by the warranty. The finish has been manufactured to a commercially acceptable standard and its condition is dependent upon the care of the user.

Top Burner Valves

The top burner flame size should be adjusted so that it does not extend beyond the edge of the cookware. As a matter of safety, it's recommended that you comply with these instructions.

A high flame on a surface burner is both inefficient and unsafe. The flame should always be adjusted so that it is no larger than the bottom of the cookware. Fluctuations in flame size could be caused by pressure variations, improperly positioned burners, damage or debris.

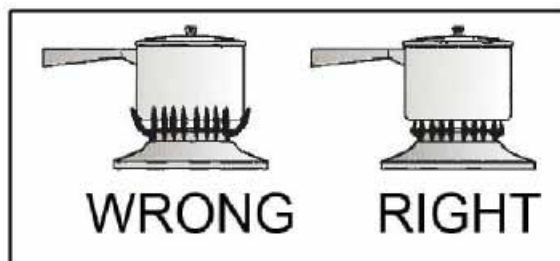

NEVER LEAVE THE CONTROL KNOBS IN ANY POSITION OTHER THAN "OFF" IF THE IGNITORS OR BURNERS AREN'T WORKING PROPERLY.

To Operate the Surface Burners

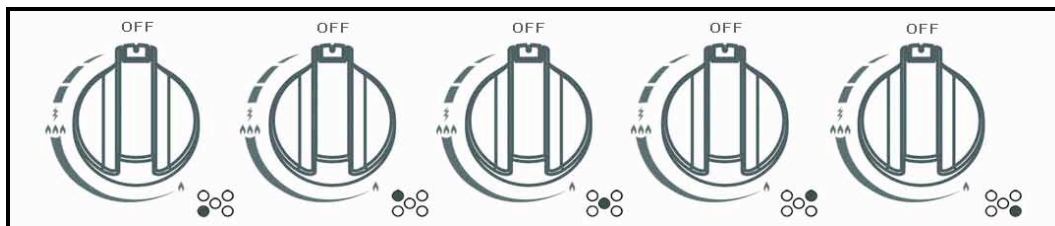

Knob Symbols

Off	Off
High Flame	🔥🔥🔥
Low Flame	🔥
Ignition	⚡
Burner Position	•

Lighting the burners

1. To obtain a flame more easily, light the burner before placing cookware on the burner grate.
2. Decide which burner you're igniting first using the screened diagram below each burner knob. The black dot indicates the position of the burner you will be igniting.
3. To light a burner, press the burner knob in and turn counter clockwise within the dashed area. You will hear the electronic ignition clicking as you continue to hold the knob down until the flame lights. Once the burner is lit you can then release the knob.
4. After lighting the flame, turn the control knob to adjust the flame size as required.
5. In the instance of a power outage when using the 110V electronic ignition option, one can still use the cooktop by placing a lit match next to the desired burner and proceed as already described. If using the battery ignition, check that your batteries have adequate voltage by replacing them. If the burner still does not light after a few attempts, check that the "burner cap" and "flame cap" are correctly positioned and that there are no spider webs in the burner cavity.

CLEANING THE COOKTOP

Always keep cleaning materials and chemicals in a safe place and away from children. Know what you are using. Make sure all parts of the cooktop are COOL before cleaning. Be sure to replace the parts correctly.

Knobs

Wash in a water solution with a mild detergent mix. Do not use an abrasive cleaner or any abrasive action.

Grates and burner caps

Clean burner grates in a water solution with a mild detergent mix.

Burners Heads

The holes in the burners of your cooktop MUST be kept clean at all times for proper ignition and a complete, even flame. Remove any food from between the burner slots using a small nonabrasive brush like a soft toothbrush and afterwards wipe using a damp cloth. To remove deposits from the burner cavities, remove the cap and separate the two parts. Clean the burner holes routinely with a small gauge wire or needle (especially after bad spillovers which could clog these holes). After cleaning, put the two parts back together and return them correctly to their position, making sure they are seated and level. DO NOT put burner units in the dishwasher.

Stainless Steel Top

Clean stainless steel with hot, soapy water and a dishcloth. Rinse with clean water and a cloth. Do not use cleaners with high concentrations of chlorides or chlorines. Do not use harsh scrubbing cleaners. Only use kitchen cleaners that are especially made for cleaning stainless steel.

Repair Parts

When repair parts are needed, contact the dealer from whom the cooktop was purchased. In case your cooktop was purchased from a source other than an appliance dealer, you may prefer to contact the manufacturer at the address shown in this manual.

HOW TO GAIN ACCESS TO THE BATTERY COMPARTMENT

Locating and Replacing Batteries

Gaining access to the battery compartment:

1. Location of the battery box in on the left underside of the cooktop.
2. Using a Philips screwdriver, remove the screw allowing for the access door to open.
3. Replace the D size battery with the positive connection facing the back of the cooktop.
4. Secure the battery and then reverse step 2.

Gas Cooktop Conversion and Adjustment Guide

The cooktop is set for use with Liquefied Petroleum (LP). The factory setting is indicated on the serial plate. When set for Natural Gas (NG) operation, the pressure regulator will regulate the pressure to 4 inches water column. When set for LP Gas operation, the pressure regulator will regulate the gas to 10 inches water column pressure.

LPG to NG Conversion

Convertible Pressure Regulator

The cooktops are shipped to operate on LPG. NG orifices are shipped with the unit in a separate envelope with the manual. The inlet pressure of the gas supply shall be in accordance with the nominal inlet pressure of the regulator used on the cooktop or 1/2 psig maximum. The cooktop should be tested by pressurizing the regulator with an inlet pressure at least 1 inch water column above the manufacturer's specified manifold pressure shown on the serial plate.

1. Shut off gas leading to appliance.
2. Unplug any electrical connections if you are using the 110V option, usually located under the cooktop.
3. Locate convertible regulator under the cooktop, remove cap and pop out the pin that's attached.
4. Below you will see the pin position for use with LPG.



5. Pull out pin and flip it to the NG position – see below.



6. Below is an example of both positions.

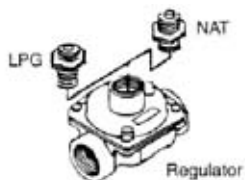

7. Replace the cap back on the regulator.
8. Next you will remove the grates, burners and burner caps from the cooktop to access the orifices.
9. You will need a 7mm wrench to remove the orifices. Each orifice can be accessed easily - the larger burner orifice is located on the burner wall.

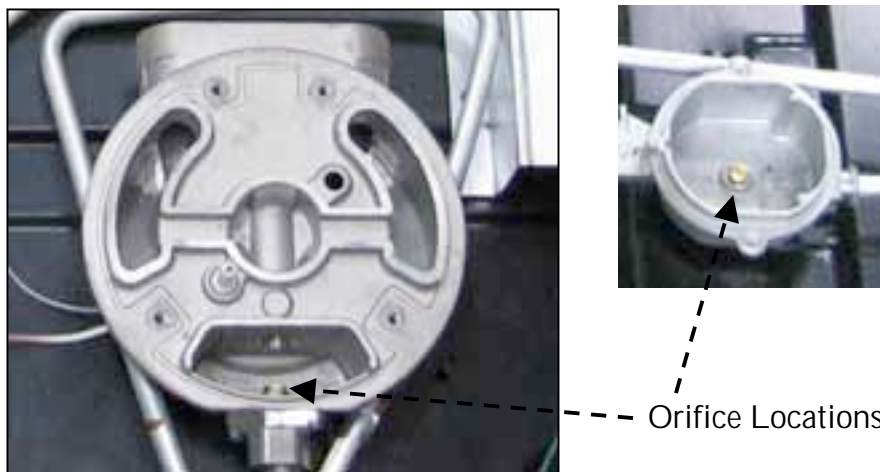

10. Remove all LPG orifices: place in the bag and store in a safe place.
11. Take the NG orifices provided and install them as shown below.

See below for rating of orifice for each model

NG	LF	LR	Middle/Center	RF	RR
24"	1.65 mm	1.17 mm	N/A	2.40mm	0.90mm
30"	1.50 mm	1.12 mm	2.10 mm	1.50 mm	0.80 mm
36"	1.50 mm	1.12 mm	2.11 mm	1.52 mm	0.86 mm

12. Once all the orifices are installed, replace all burners and burner caps, then fire up the burners to check the minimum flame height.
13. Minimum flame height should be approx. 1/4" tall. You will want a small minimum flame for simmering (especially on the small burners). There is a small adjustment screw located on the valve itself, the lid must be removed in order to make the adjustment. Once the lid is off, pop off the black square cap and make the adjustment (counter clockwise for a smaller flame and clockwise for a larger

flame adjustment). If you have a small enough screwdriver, you will not need to pop off the black cap.

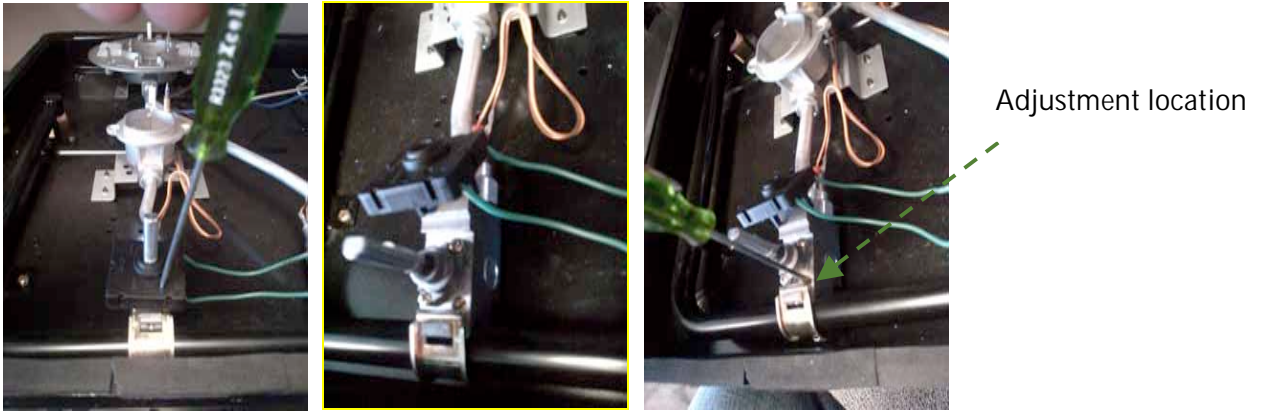

14. Replace the lid, burners, burner caps and grates and recheck the flame.

Wiring diagrams - all models

UGP 24 CT

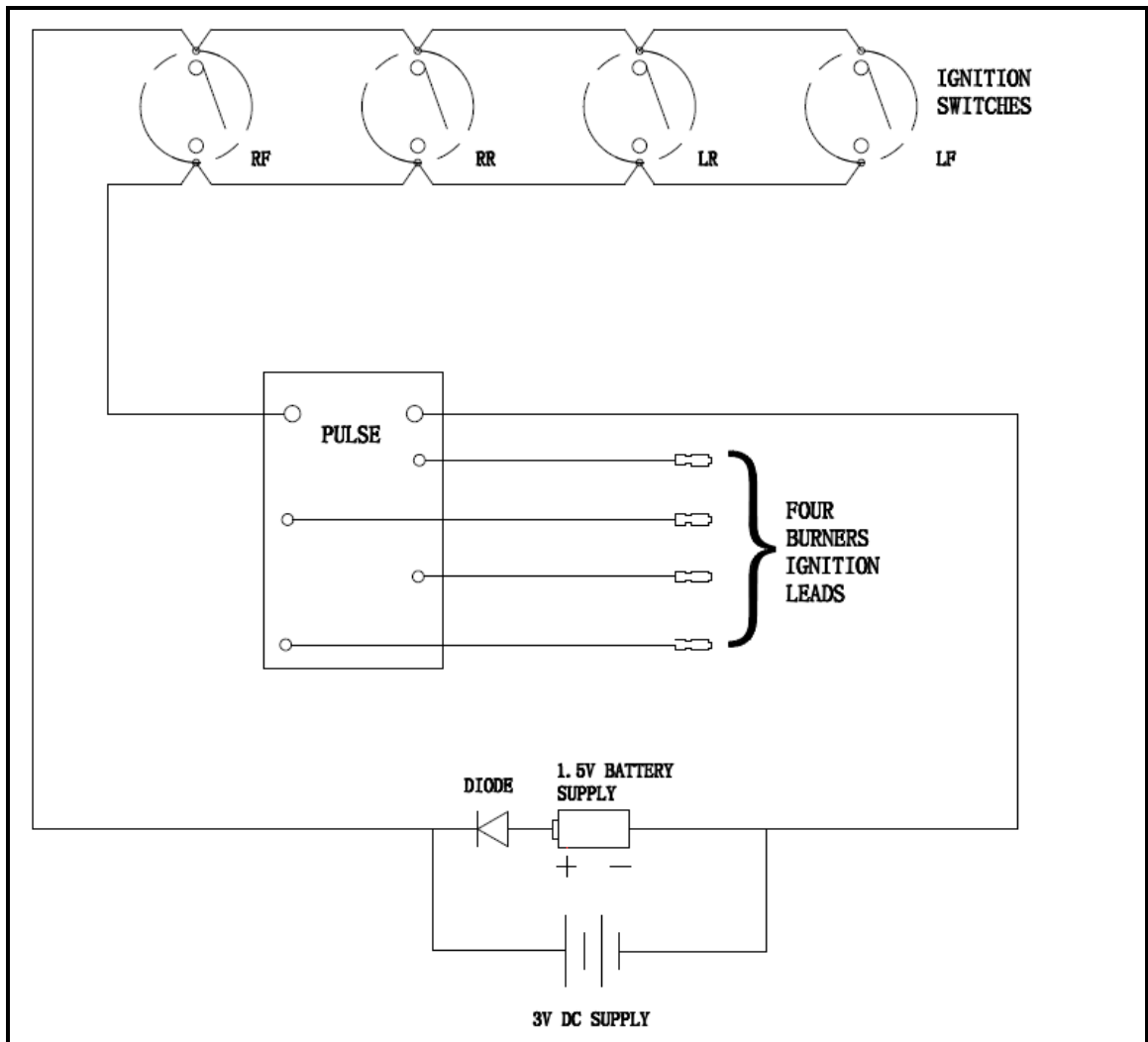

UGP 30 CT

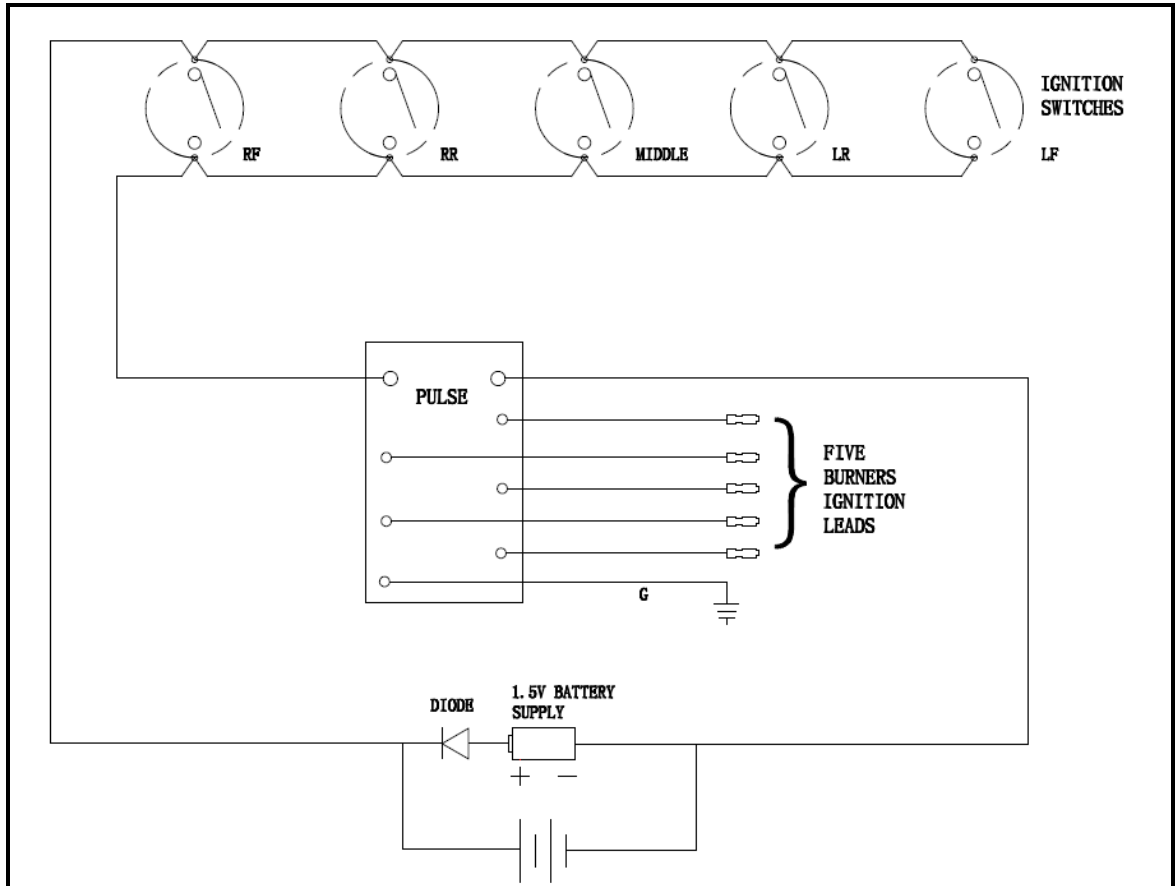

UGP 36 CT

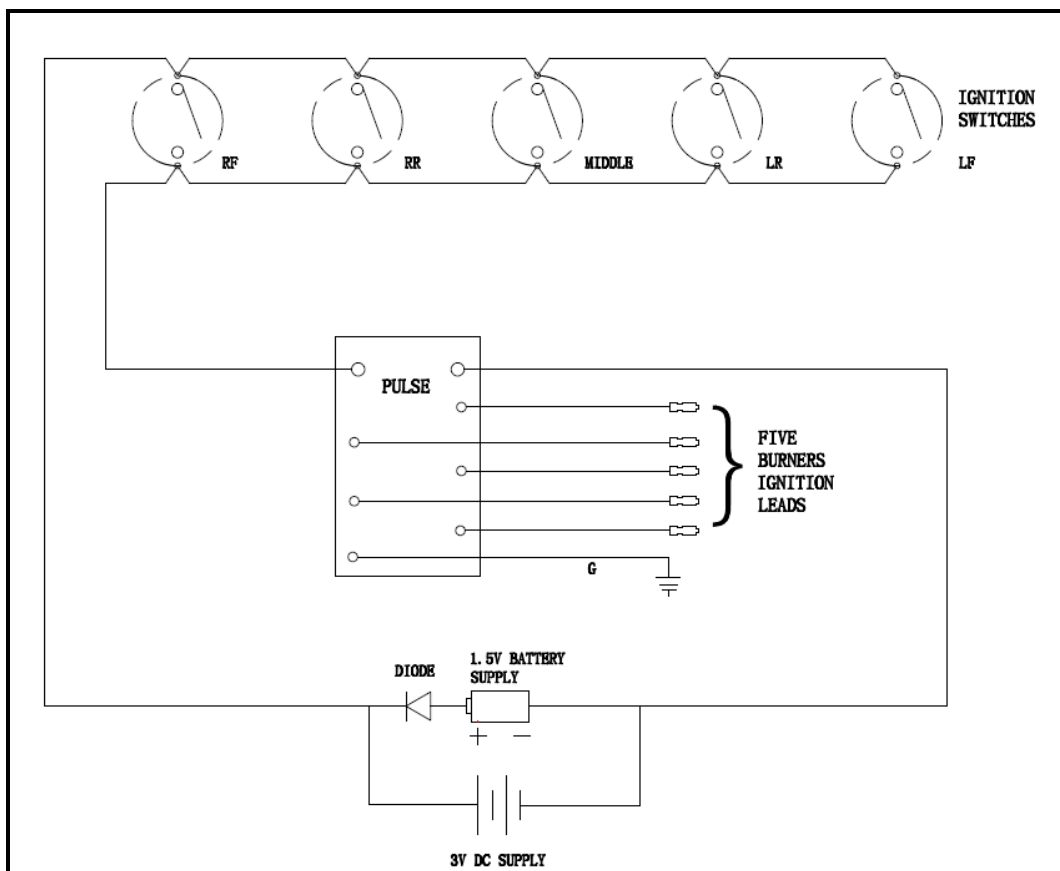

Parts Lists - all models

UGP 24 CT - drawing

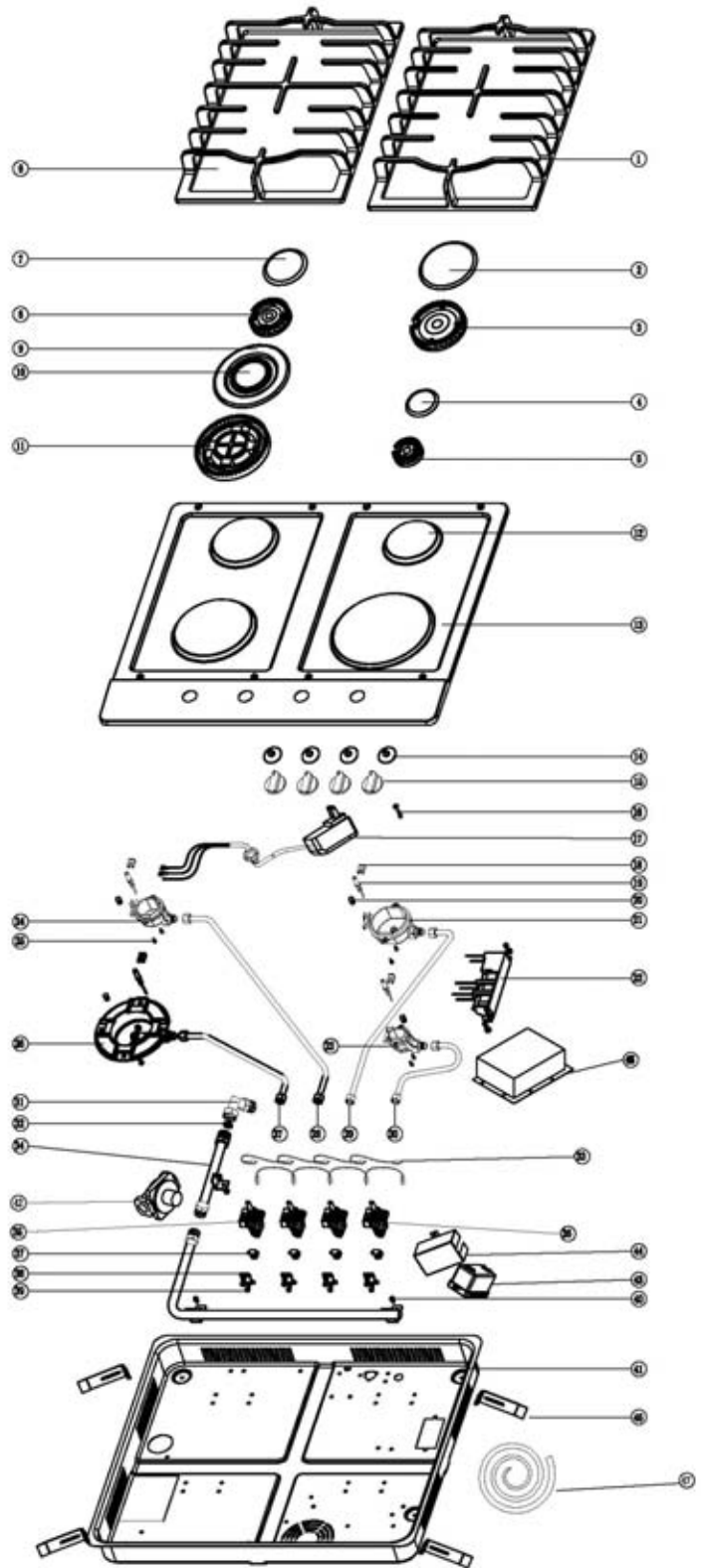

UGP 30 CT- Drawing

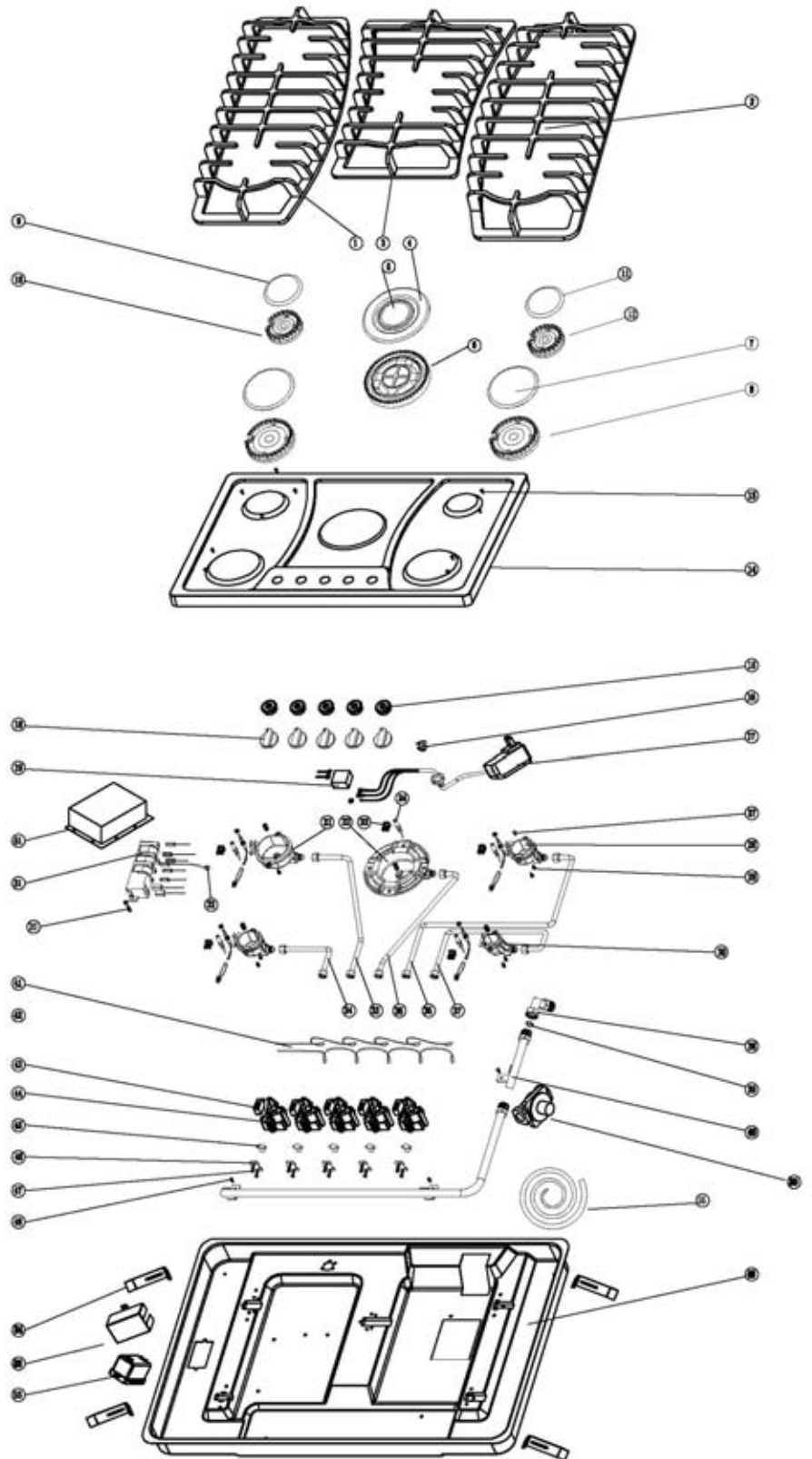

UGP 36 CT - Drawing

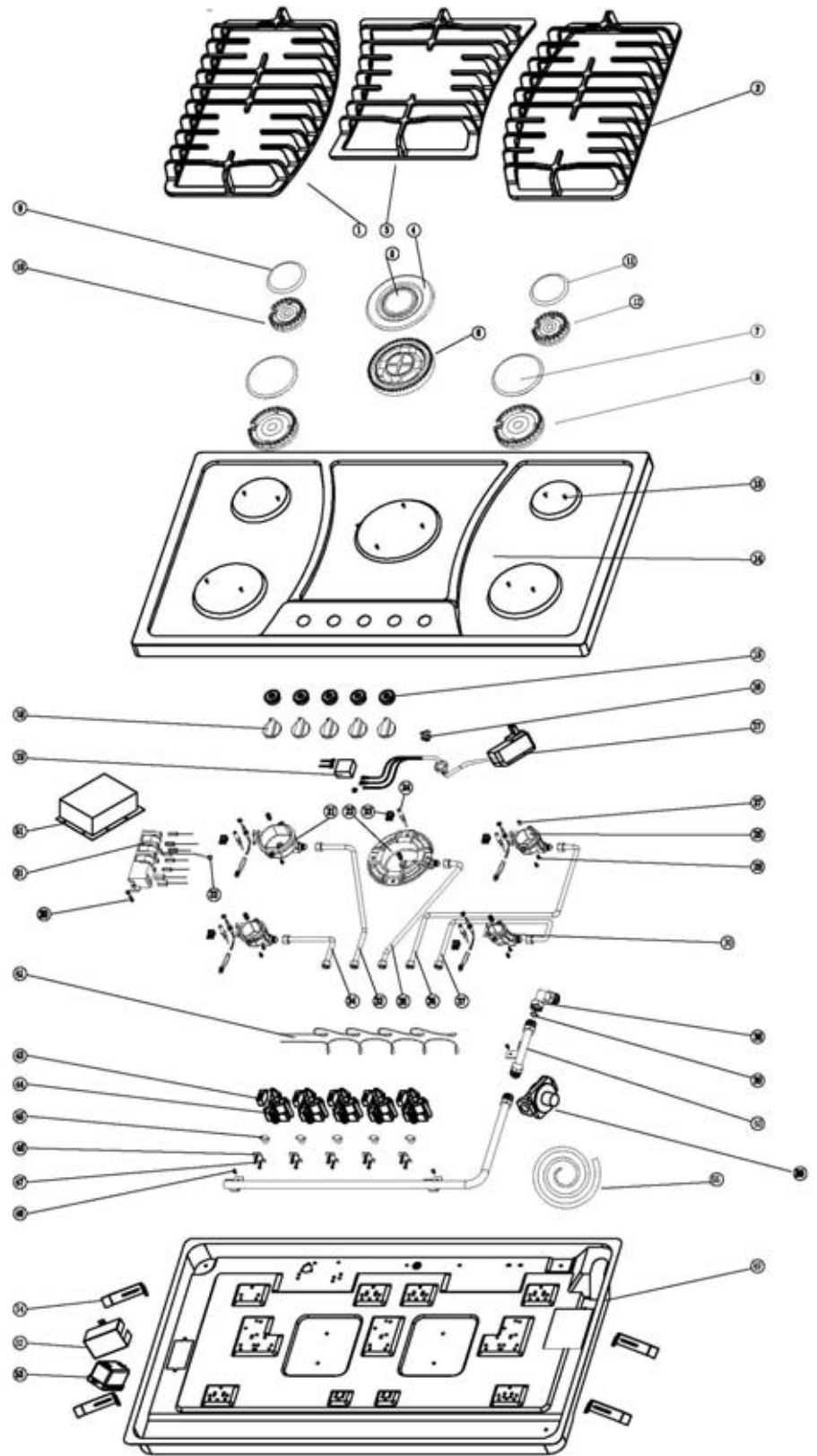

UGP24CT		
#	Description	Part #
1	Cast Iron Grates - Same for both sides	UGP-Z10001
2	#2 Burner cap	UGP-Z10002
3	#2 Aluminum burner	UGP-Z10003
4	#4 Burner cap	UGP-Z10004
5	#4 Aluminum burner	UGP-Z10005
6	Same as #1	UGP-Z10006
7	#3 Burner cap	UGP-Z10007
8	#3 Aluminum burner	UGP-Z10008
9	#1 Big burner cap	UGP-Z10009
10	#1 Small burner cap	UGP-Z10010
11	#1 Aluminum burner	UGP-Z10011
12	Set screws for panel	UGP-Z10012
13	Stainless steel panel	UGP-Z10013
14	Waterproof silicone seal	UGP-Z10014
15	Knobs	UGP-Z10015
16	Power cord clamp	UGP-Z10016
17	Plug in	UGP-Z10017
18	Ignition stator	UGP-Z10018
19	Ignition electrode	UGP-Z10019
20	Orifice	UGP-Z10020
21	#2 Aluminum burner bottom	UGP-Z10021
22	Pulse Module	UGP-Z10022
23	#4 Aluminum burner bottom	UGP-Z10023
24	#3 Aluminum burner bottom	UGP-Z10024
25	Screws for aluminum burner bottom	UGP-Z10025
26	#1 Aluminum burner bottom	UGP-Z10026
27	#1 Aluminum burner pipe	UGP-Z10027
28	#3 Aluminum pipe	UGP-Z10028
29	#2 Aluminum Pipe	UGP-Z10029
30	#4 Aluminum pipe	UGP-Z10030
31	Inlet pipe connection	UGP-Z10031
32	Silicone Seal	UGP-Z10032
33	Connecting wire	UGP-Z10033
34	Inlet pipe	UGP-Z10034
35	Microswitch	UGP-Z10035
36	Valve body	UGP-Z10036
37	Silicone seal	UGP-Z10037
38	Valve Body clip	UGP-Z10038
39	Screws for valve body clip	UGP-Z10039
40	Screws for air inlet pipe	UGP-Z10040

#	Description	Part #
41	Cooktop base	UGP-Z10041
42	Regulator	UGP-Z10042
43	Battery house	UGP-Z10043
44	Heat shield battery module	UGP-Z10044
45	Heat shield Electronic ignition	UGP-Z10045
46	Support Clips	UGP-Z10046
47	Foam	UGP-Z10047

UGP30CT		
#	Description	Part #
1	Cast Iron Grate - Left	UGP-Z100048
2	Cast Iron Grate - Right	UGP-Z100049
3	Cast iron Grate - Middle	UGP-Z100050
4	#1 Big burner cap	UGP-Z10009
5	#1 Small burner cap	UGP-Z10010
6	#1 Big burner	UGP-Z10011
7	#2 Burner cap	UGP-Z10002
8	#2 Aluminum burner	UGP-Z10003
9	#3 Burner cap	UGP-Z10007
10	#3 Aluminum burner	UGP-Z10008
11	#4 Burner cap	UGP-Z10004
12	#4 Aluminum burner	UGP-Z10005
13	Set screws for panel	UGP-Z10012
14	Stainless steel panel	UGP-Z100051
15	Waterproof silicone seal	UGP-Z10014
16	Power cord clamp	UGP-Z10016
17	Plug in	UGP-Z10017
18	Knobs	UGP-Z10015
19	Power junction box	UGP-Z100052
20	Screw	UGP-Z100053
21	#2 Aluminum burner bottom	UGP-Z10021
22	#1 Aluminum burner bottom	UGP-Z10026
23	Ignition stator	UGP-Z10018
24	Ignition electrode	UGP-Z10019
25	Nut	UGP-Z100054
26	N/A	
27	Orifice	UGP-Z10020
28	#3 Aluminum burner bottom	UGP-Z10024
29	Screws for aluminum burner bottom	UGP-Z10025
30	#4 Aluminum burner bottom	UGP-Z10023
31	Pulse module	UGP-Z10022
32	Pulse Ground wire	UGP-Z100055
33	#3 Aluminum Pipe	UGP-Z10028
34	#2 Aluminum pipe	UGP-Z10029
35	#1 Aluminum pipe	UGP-Z10027
36	#4 Aluminum pipe	UGP-Z10030
37	#2 aluminum pipe	UGP-Z10029
38	Inlet pipe connection	UGP-Z10034
39	Silicone seal	UGP-Z10037

#	Description	Part #
40	Inlet pipe	UGP-Z10034
41	Connecting wire	UGP-Z10033
42	N/A	
43	Microswitch	UGP-Z10035
44	Valve body	UGP-Z10036
45	Silicone seal	UGP-Z10037
46	Valve body clip	UGP-Z10038
47	Screws for valve body clip	UGP-Z10039
48	Screws for air inlet pipe	UGP-Z10040
49	Cooktop base	UGP-Z100056
50	Regulator	UGP-Z10042
51	Heat shield pulse ignition	UGP-Z10045
52	Heat shield battery box	UGP-Z10044
53	Battery Box	UGP-Z10043
54	Retaining clip	UGP-Z10046
55	Foam	UGP-Z100057

UGP306CT		
#	Description	Part #
1	Cast Iron Grate - Left	UGP-Z100058
2	Cast Iron Grate - Right	UGP-Z100059
3	Cast iron Grate - Middle	UGP-Z100060
4	#1 Big burner cap	UGP-Z10009
5	#1 Small burner cap	UGP-Z10010
6	#1 Big burner	UGP-Z10011
7	#2 Burner cap	UGP-Z10002
8	#2 Aluminum burner	UGP-Z10003
9	#3 Burner cap	UGP-Z10007
10	#3 Aluminum burner	UGP-Z10008
11	#4 Burner cap	UGP-Z10004
12	#4 Aluminum burner	UGP-Z10005
13	Set screws for panel	UGP-Z10012
14	Stainless steel panel	UGP-Z100061
15	Waterproof silicone seal	UGP-Z10014
16	Power cord clamp	UGP-Z10016
17	Battery and plug in	UGP-Z10017
18	Knobs	UGP-Z10015
19	Power junction box	UGP-Z100051
20	Screw	UGP-Z100052
21	#2 Aluminum burner bottom	UGP-Z10021
22	#1 Aluminum burner bottom	UGP-Z10026
23	Ignition stator	UGP-Z10018
24	Ignition electrode	UGP-Z10019
25	Nut	UGP-Z100053
26	N/A	
27	Orifice	UGP-Z10020
28	#3 Aluminum burner bottom	UGP-Z10024
29	Screws for aluminum burner bottom	UGP-Z10025
30	#4 Aluminum burner bottom	UGP-Z10023
31	Pulse module	UGP-Z10022
32	Pulse Ground wire	UGP-Z100054
33	#3 Aluminum Pipe	UGP-Z10028
34	#2 Aluminum pipe	UGP-Z10029
35	#1 Aluminum pipe	UGP-Z10027
36	#4 Aluminum pipe	UGP-Z10030
37	#2 aluminum pipe	UGP-Z10029
38	Inlet pipe connection	UGP-Z10034

#	Description	Part #
39	Silicone seal	UGP-Z10037
40	Inlet pipe	UGP-Z10034
41	Connecting wire	UGP-Z10033
42	N/A	
43	Microswitch	UGP-Z10035
44	Valve body	UGP-Z10036
45	Silicone seal	UGP-Z10037
46	Valve body clip	UGP-Z10038
47	Screws for valve body clip	UGP-Z10039
48	Screws for air inlet pipe	UGP-Z10040
49	Cooktop base	UGP-Z100062
50	Regulator	UGP-Z10042
51	Heat shield pulse ignition	UGP-Z10045
52	Heat shield battery box	UGP-Z10044
53	Battery Box	UGP-Z10043
54	Retaining clip	UGP-Z10046
55	Foam	UGP-Z100063

UNIQUE UGP 24CT/30CT/36CT Cooktops 1 YEAR LIMITED WARRANTY*

Unique Gas Products Ltd. warrants that this UNIQUE cooktop is free from defects in material and workmanship under normal usage and service under the following terms:

Parts Warranty

This appliance has been designed for domestic household use. If properly installed, adjusted and operated under normal conditions (in accordance with the printed instructions), it will satisfactorily perform the functions that are generally expected of this type of appliance.

If the appliance fails to do so because of a defect in material or workmanship (note - within one year from the original date of purchase):

Unique will at our option, repair, exchange, or correct by other means Unique considers appropriate, any part(s) we find to be defective except for the surface finish. ***Due to remote locations, it is the customer's responsibility to bring items to the dealer for review.** ("Carry in" warranty) Any part(s) replaced or repaired will be warranted only for the balance of the original year. **Customer is responsible for labor.**

Ownership

This Warranty is made only to the first purchaser ("original purchaser") who acquires this cooktop for his/her own use and will be honored by **Unique Gas Products Ltd.** and by the Seller. Purchaser must retain their original receipt as proof of purchase date.

Warranty Conditions

This warranty does not apply to any appliance that has been subjected to alterations, misuse, abuse (including damage by foreign agents or chemicals), accident, improper installation or service, delivery damage, or other than normal household use and service.

This UNIQUE appliance **must** be serviced regularly as outlined in the Owners Manual.

Neither Unique Gas Products Ltd. nor the selling dealer will be liable for direct or indirect loss of foods caused by failure in operation. In case of damage, the owner must provide proof of purchase, Model, and Serial Number to the selling dealer or **Unique Gas Products Ltd.**

This warranty is LIMITED STRICTLY to the terms indicated herein, and no other expressed warranties or remedies thereunder shall be binding on Unique.

Purchaser's Responsibilities

The purchaser will be responsible for the costs of any service calls requested to demonstrate or confirm the proper operation of the appliance, the installation, or to correct malfunctions in the appearance created by the operation of the appliance in a manner not prescribed by or cautioned against in the use and care instructions.

Model and Serial Number

The appliance model number and serial number can be found on a rating plate attached underneath the appliance. The purchaser should always refer to the model and serial number when talking to or contacting the dealer from whom the appliance was purchased.

Factory Assistance

If the purchaser is unable to locate an authorized dealer/service agent, or receive satisfaction from the dealer, they may contact Unique Gas Products - Customer Service directly at Toll Free 1-877-427-2266 or 905-827-6154

Unique Gas Products Ltd, 2245 Wycroft Road #5, Oakville, Ontario, Canada, L6L 5L7

Ph: 905-827-6154 Toll Free: 1-877-427-2266 Fax: 905-827-2027

www.UniqueOffGrid.com

e-mail: info@UniqueOffGrid.com