

502 1/8"-3"

Bronze Globe Valve
125 SWP - 200 WOG †
Bronze Disc
Threaded Bonnet • Threaded Ends
Conforms to: MSS SP-80

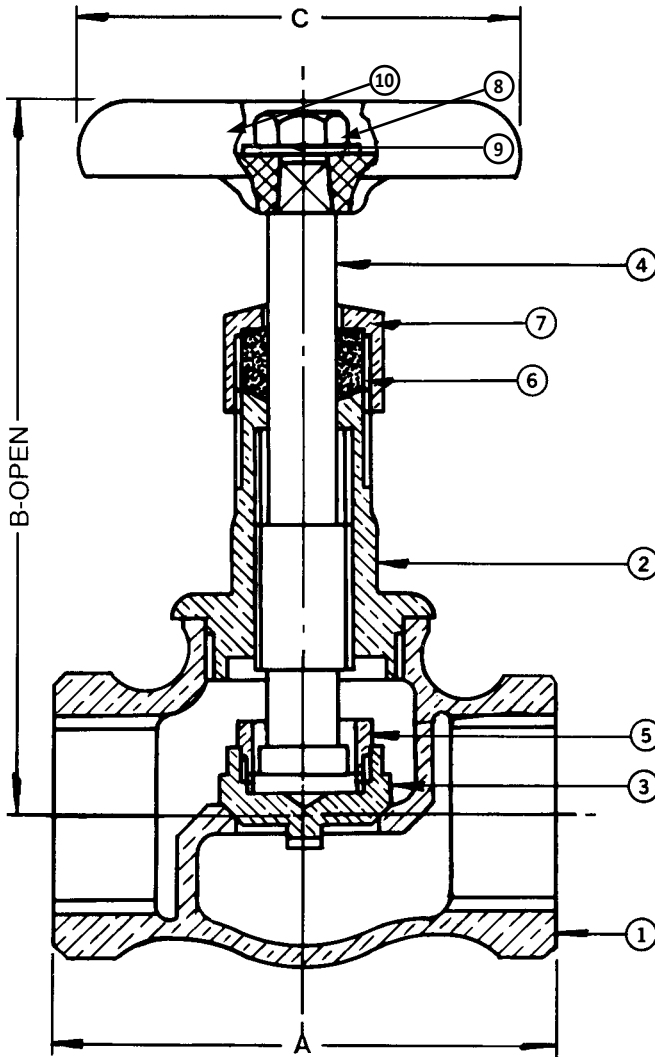

Note: Not intended for use in potable water.

MATERIAL LIST			
No.	PART	MATERIAL	SPECIFICATION
1	Body	Bronze	ASTM B62
2	Bonnet	Bronze	ASTM B62
3	Disc	Bronze	ASTM B62
4	Stem	Bronze	ASTM B16
5	Disc Ring	Brass	ASTM B16 3/4" to 2" ASTM B62 2 1/2" and 3"
6	Packing	Graphite	Commercial
7	Packing Nut	Brass	ASTM B16
8	Handwheel	Mall. Iron	Commercial
9	Name Plate	Aluminum	Commercial
10	Handwheel Nut	Brass	Commercial
11	Gland (not shown)	Brass	ASTM B16 2 1/2" and 3" only

1/8" to 1/2" sizes have the disc integral with the stem and have no disc ring.

DIMENSIONS - INCHES/MILLIMETERS					
Units	Size	A	B	C	C _v
Inches mm	1/8	1.63 41	3.06 78	2.00 51	0.61
Inches mm	1/4	1.63 41	3.06 78	2.00 51	1.16
Inches mm	3/8	1.81 46	3.19 81	2.00 51	2.21
Inches mm	1/2	2.31 59	3.63 92	2.25 57	3.64
Inches mm	3/4	2.56 65	3.94 100	2.50 64	6.65
Inches mm	1	2.94 75	4.38 111	2.75 70	11.10
Inches mm	1 1/4	3.38 86	5.19 132	3.13 79	20.00
Inches mm	1 1/2	3.69 94	5.75 146	3.50 89	28.00
Inches mm	2	4.44 113	6.75 172	4.00 102	48.00
Inches mm	2 1/2	5.75 146	8.63 219	4.75 121	70.00
Inches mm	3	6.88 175	9.25 235	5.50 140	111.00

† Non-Shock

INNOVATION IN EVERY VALVE

The information presented on this sheet is correct at time of publication. Milwaukee Valve reserves the right to change design and/or materials without notice. For our Installation, Operation and Maintenance Manual and the most current product information go to www.milwaukeevalve.com. State of California Prop 65
WARNING: Cancer and Reproductive Harm. For more information visit www.p65warnings.ca.gov.

MILWAUKEE VALVE