

130 ERVD

ENERGY RECOVERY VENTILATOR

Cold weather certified for year-round ventilation

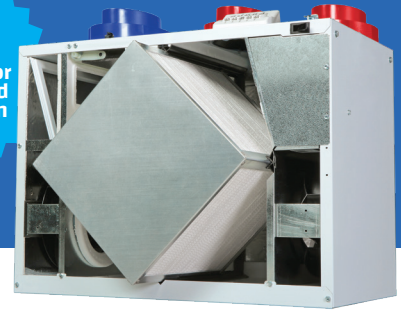

SUPERIOR PERFORMANCE TOP CHOICE ERV

The compact design of the 130 ERVD model combined with superior performance, makes Lifebreath the top choice. Three units in one by the way of the high-speed select feature allows for maximum control of airflow and comfort. Features a top port design, door port balancing, 5 in. duct connections and our ERV core.

- HVI Cold weather certified ERV
- Enthalpy energy exchange core
- Top port design with built-in balancing dampers
- Intelligent defrost damper motor
 - Smart damper with integrated circuit board
 - Energy-efficient DC motor
 - Power-saving standby mode
 - Integrated Ice Breaker technology
- Energy Star rated

ENGINEERING DATA:

TOTAL RECOVERY CORE

Cross-flow energy recover core transfers heat and water vapor between two airstreams. Easily removed for cleaning or service.

MOTORS AND BLOWERS

Each airstream has an independent motorized impeller with multiple fan speed operation.

FILTERS

Washable MERV-6 air filters in exhaust and supply airstreams. Upgrade to MERV-13 option available.

MOUNTING

Adjustable hanging straps supplied.

DEFROST

Recirculating damper defrost system.

CASE

20 gauge prepainted galvanized steel for superior corrosion resistance, insulated to prevent exterior condensation.

INSTALLER SELECTABLE HIGH SPEED SETTINGS

Adjustable DIP switches are located on the circuit board, Hi3 is the factory setting. Refer to the installation manual for the adjustment instructions.

ELECTRONICS

Main control can be wall mounted in a central location. 3 wire 20 gauge (min.) 100 ft. length (max.)

OPTIONAL ACCESSORIES:

Dual Hood
99-190
99-194



Weather Hood
99-185
99-186
99-187



TechGrille
99-EAG4
99-EAG5
99-EAG6
99-EAG8



Terminator Fitting
99-TM4
99-TM5
99-TM6



LIFEBREATH CONTROL OPTIONS

FEATURES	99-DXPLO2	99-BC02	99-BC03	99-BC04
5 speed fan operation on each mode	✓			
2 speed fan operation (Low/High)		✓		✓
Continuous low speed fan operation	✓	✓	✓	✓
Humidity control through adjustable Dehumid-istat	✓	✓	✓	
Large digital LCD screen	✓			
LED status indicator lights		✓	✓	✓
Continuous Ventilation	✓	✓	✓	✓
Continuous Recirculation*	✓		✓	
20 ON/40 OFF	✓		✓	✓
10 ON/50 OFF	✓			
20 ON/40 Recirculation*	✓		✓	✓
20/40/60 min. High speed override button	✓			
Compatible with 99-DET02 Wireless Timer	✓	✓	✓	✓
3 wire connection	✓	✓	✓	✓

*Recirculation features not available on fan defrost models.

130 ERVD - 1122

TIMER OPTIONS

99-DET01 - 20/40/60 Minute Timer

Initiates high speed ventilation for 20, 40 or 60 minutes. 3 wire connection.

99-DET02 - 20/40/60 Minute Timer

Initiates high speed ventilation for 20, 40 or 60 minutes. Wirelessly connects to main control for ease of installation. 40 ft approximate range.

99-RX02 - Wireless Repeater

Extends range of 99-DET02 Wireless Timers. Plugs into 120V power outlet. Wirelessly connects to main control and 99-DET02. Install at halfway point between timer and main wall control if timer is out of range.



99-BC02

99-BC03

99-BC04

99-DET02

99-DET01

LIFEBREATH
Indoor Air Systems

www.lifebreath.com

130 ERVD

ENERGY RECOVERY VENTILATOR

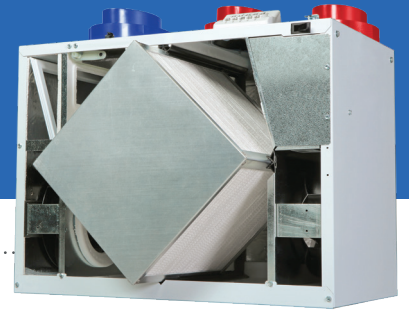

PERFORMANCE (HVI CERTIFIED)

IN. W.G. (PA)	0.2 (50) CFM (L/s)	0.3 (75) CFM (L/s)	0.4 (100) CFM (L/s)	0.5 (125) CFM (L/s)	0.6 (150) CFM (L/s)	0.7 (175) CFM (L/s)	0.8 (200) CFM (L/s)	0.9 (225) CFM (L/s)
Net Supply Airflow	155 (73)	146 (69)	138 (65)	127 (60)	117 (55)	104 (49)	93 (44)	83 (39)
Gross Supply Airflow	157 (74)	148 (70)	140 (66)	129 (61)	117 (55)	106 (50)	95 (45)	85 (40)
Gross Exhaust Airflow	140 (66)	131 (62)	123 (58)	114 (54)	106 (50)	97 (46)	89 (42)	81 (38)

ELECTRICAL SPECIFICATIONS	
VAC @ 60Hz	120
Watts / Low Speed	66
Watts / High Speed	102
Amp Rating	1.7

Sensible Effectiveness (ASE) @ 64 CFM (30 L/s)	32°F (0°C)	86%
Sensible Efficiency (SRE) @ 102 CFM (48 L/s)	32°F (0°C)	70%
Sensible Efficiency (SRE) @ 64 CFM (30 L/s)	32°F (0°C)	75%
Sensible Efficiency (SRE) @ 70 CFM (33 L/s)	-13°F (-25°C)	60%
Total Efficiency (TRE) @ 66 CFM (31 L/s)	95°F (35°C)	48%

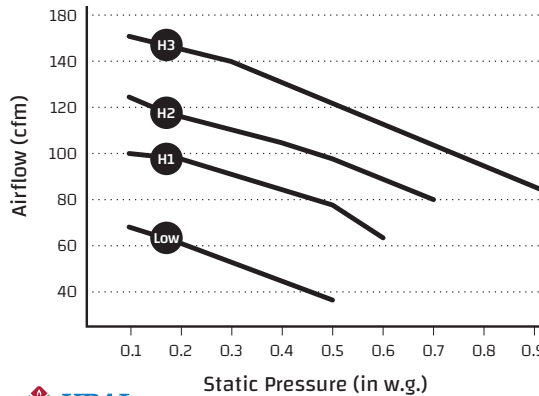

WEIGHT:
51 LBS (23 KG)

SHIPPING WEIGHT:
54 LBS (25 KG)

NOTE:
Front clearance of 25 in. (635 mm) is recommended for servicing unit. All ducts use 5 in. (125 mm) round collars. Balancing dampers are located on all collars.

MERV 13 Upgrade: 65-195-6R



This product earned the ENERGY STAR® by meeting strict energy efficiency guidelines set by Natural Resources Canada and the US EPA. It meets ENERGY STAR® requirements only when used in Canada.

DIMENSIONS

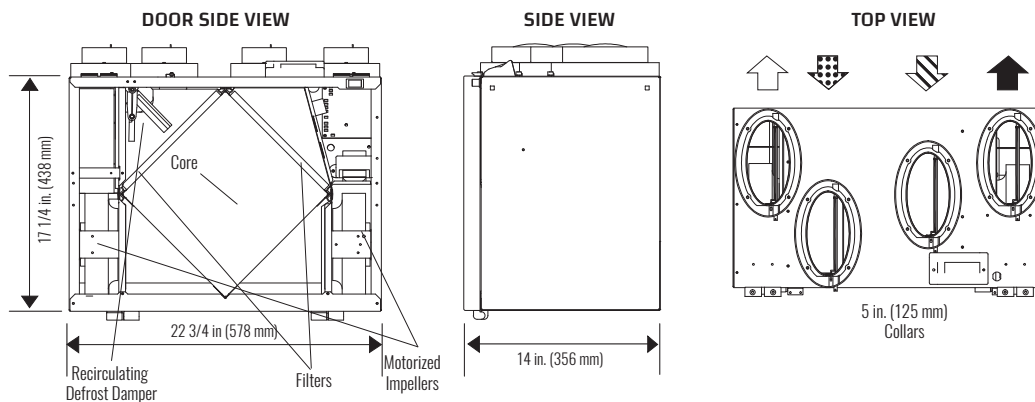

Date: _____

Contractor: _____

Tag: _____

Supplier: _____

Project: _____ Qty: _____

Quote #: _____

Engineer: _____

Submitted By: _____

Control: _____

Timer: _____ Timer Qty: _____

WARRANTY

Units carry a 5 year warranty on the enthalpic (ERV) core and a 5 year replacement parts warranty.

All units conform to CSA and UL standards

