



ENERGY RECOVERY VENTILATORS

ERV

**30 ERV
130 ERVD
170 ERVD
267MAX ERV**

Installation Manual

Pre-Installation Notes



Note

- Due to ongoing research and product development, specifications, ratings, and dimensions are subject to change without notice. Refer to www.lifebreath.com for the latest product information.



Attention

- Do not apply electrical power to the unit until after the completion of the installation (including installation of low voltage control wiring).
- Ensure the installation and wiring is in accordance with CEC, NEC, and local electrical codes.
- Plug the unit into a standard designated (120 VAC) electrical outlet with ground.
- The use of an extension cord with this unit is not recommended. If the installation requires further wiring, have a licensed electrician make all the electrical connections. The recommended circuit is a separate 15 A/120 V circuit.



Caution

- Before installation, careful consideration must be given to how this system will operate if connected to any other piece of mechanical equipment, i.e. a forced air furnace or air handler, operating at a higher static. After installation, the compatibility of the two pieces of equipment must be confirmed, by measuring the airflows of the ERV, by using the balancing procedure found in this manual. Never install a ventilator in a situation where its normal operation, lack of operation or partial failure may result in the back drafting or improper functioning of vented combustion equipment
- Unit must be installed level to ensure proper condensate drainage. Due to the broad range of installation and operational conditions, consider the possibility of condensation forming on either the unit or connecting ducting. Objects below the installation may be exposed to condensate.
- Do not install control wiring alongside electrical wire.



Warning

- Disconnect the power from the unit before cleaning or servicing.
- To prevent electrical shock, it is extremely important to confirm the polarity of the power line that is switched by the safety (disconnect) switch. The hot line (black) is the proper line for switching. Use either a voltmeter or test lamp to confirm the absence of a voltage between the disconnect switch and ground (on the cabinet) while the door is open. This procedure must be followed, as dwellings are occasionally wired improperly. Always ensure the proper grounding of the unit.
- Improper installation, adjustment, alteration, service or maintenance can cause property damage, personal injury or loss of life. Installation and service must be performed by a qualified installer or service agency.

Table of Contents

1	Location Notes	4
2	Simplified Installation (Return/Return Method).....	5
3	Partially Dedicated System Installation	6
4	Fully Dedicated System Installation	7
5	Mounting (30ERV) and Plugs	8
6	Hanging Straps	9
7	Drain Connection	11
8	Grilles	12
9	Grille Fittings	13
10	Lifebreath Weather Hoods.....	14
11	Lifebreath Dual Hood	15
12	Main Control Installation (99-DXPL02)	16
13	Main Control Installation (99-BC02, -BC03, -BC04)	17
14	Interlocking the ERV	18
15	Additional Controls	19
16	Timers.....	20
16	Timers.....	21
17	Repeaters	22
18	Installer Selectable HIGH-SPEED Settings	23
19	Dimensional Drawings	24
20	Dimensional Drawings	25
21	Balancing the Airflows	26
22	Balancing the Airflows	27
23	Balancing the Airflows – Pitot Tube	28
24	Balancing the Airflows – Door Ports	29
25	Door Port Locations	30
26	Airflow Charts (130ERV Model).....	31
26	Airflow Charts (130ERV Model).....	32
27	Airflow Charts (170ERV Model).....	33
27	Airflow Charts (170ERV Model).....	34
28	Auto Balancing	35
29	Fault Indicator Display Board (FID)	36
30	Troubleshooting.....	37
30	Troubleshooting.....	38

Homeowners Warranty Information

After the installation is complete, fill out the Warranty Information page in the Homeowner’s manual.



1 LOCATION NOTES

Install the unit in a heated space that provides clearance for service access. A typical location is in either a mechanical room or an area close to the outside wall within proximity to where the weather hoods are mounted. If a basement area is inconvenient or non-existent, install the unit in a utility room or laundry room.

Leave enough clearance at the front of the access door for servicing the air filters and core. The recommended clearance is a minimum of 25 in. (635 mm) for opening and closing the door. Four straps are provided with the unit for hanging it from the basement floor joists.

Attic installations are not recommended due to:

- The complexity of work to install
- Difficulty of access for servicing and cleaning
- Freezing conditions in the attic

If attic installation is necessary, the unit must be situated in a conditioned space.

Note: ENERGY STAR®

If the unit is certified ENERGY STAR®, the following applies:

- This product earned the ENERGY STAR® by meeting strict energy efficiency guidelines set by Natural Resources Canada and the US EPA. This product meets ENERGY STAR® requirements only when used in Canada.
- To ensure quiet operation of the ENERGY STAR® certified H/ERV, each product model must be installed using sound attenuation techniques appropriate for the installation.
- The way your heat/energy-recovery ventilator is installed can make a significant difference to the electrical energy you use. To minimize the electricity, use of the heat/energy-recovery ventilator, a stand-alone fully ducted installation is recommended. If you choose a simplified installation that operates your furnace air handler for room-to-room ventilation, an electrically efficient furnace that has an electronically commutated (EC) variable speed blower motor will minimize your electrical energy consumption and operating cost.
- Installation of a user-accessible control with your product model will improve comfort and may significantly reduce the product model's energy use.

S

2 SIMPLIFIED INSTALLATION (RETURN/RETURN METHOD)

Installation Notes:

- The ERV must be balanced.
- Unit should be balanced on high speed with the furnace blower on.
- It is mandatory that the furnace blower run continuously or ERV operation be interlocked with the furnace blower.
- The duct configuration may change depending on the ERV model.
- A backdraft damper is recommended in the exhaust air duct to prevent outdoor air from entering the unit.
- The airflow must be confirmed on site using the balancing procedures found in this guide.

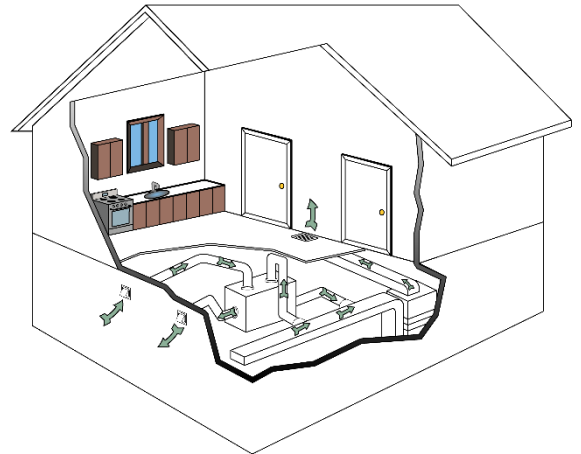

Spring-Loaded Backdraft Damper (recommended):

Install the Backdraft Damper with the leaf hinge vertical. The damper is installed on the "Stale Air to Outside Collar"

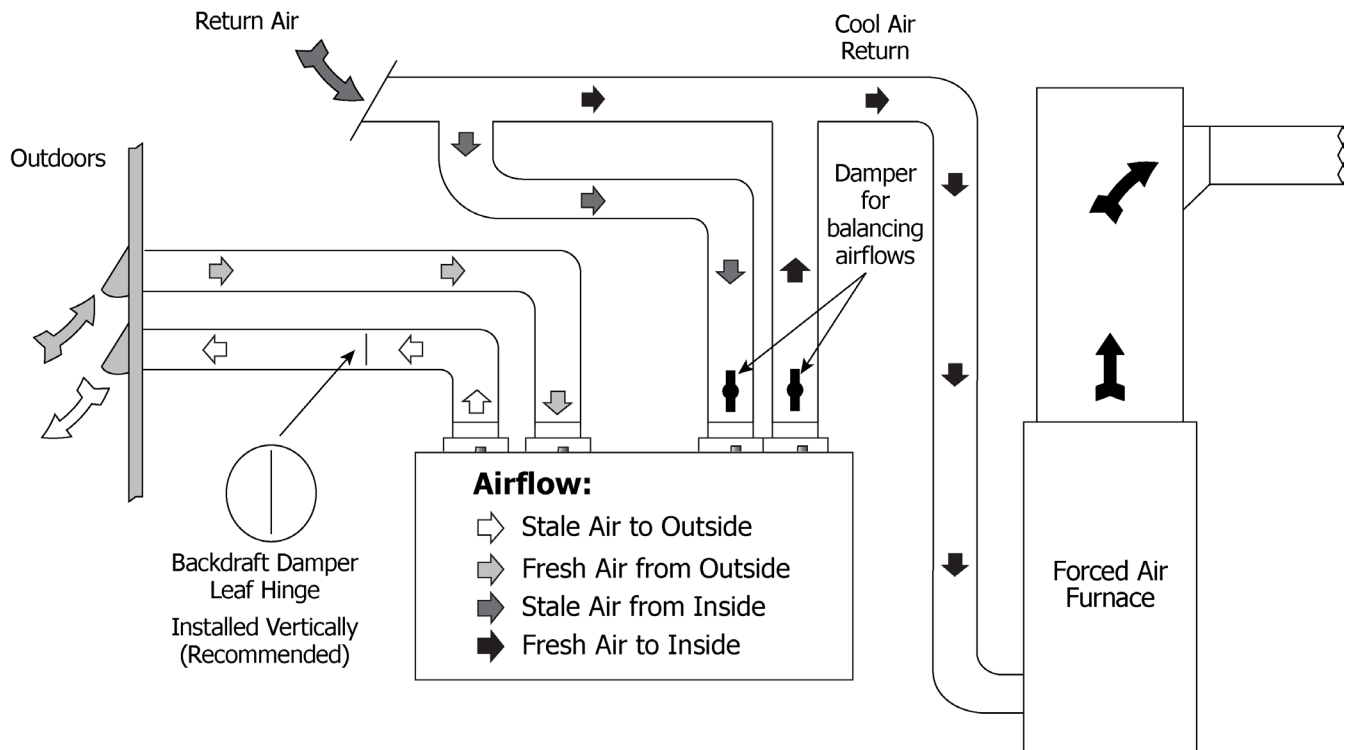

Warning

- Check local codes/authority having jurisdiction for acceptance.
- Applications such as greenhouses, atriums, swimming pools, saunas, etc. have unique ventilation requirements which should be addressed with an isolated ventilation system.
- Weatherhood arrangement is for drawing purposes only. Check local codes/authority having jurisdiction for acceptance.
- Backdraft dampers are recommended for the stale air to outside air duct. This damper prevents outdoor air from entering the ERV during the operation of the furnace/air handler while the ERV is in standby, off, or recirculating.

3 PARTIALLY DEDICATED SYSTEM INSTALLATION

Installation Notes:

- The ERV must be balanced.
- Unit should be balanced on high speed with the furnace blower on.
- It is recommended that the furnace blower run continuously or ERV operation be interlocked with the furnace blower. Refer to building code.
- The duct configuration may change depending on the ERV model.
- A backdraft damper is recommended in the exhaust air duct to prevent outdoor air from entering the unit.
- The airflow must be confirmed on site using the balancing procedures found in this guide.

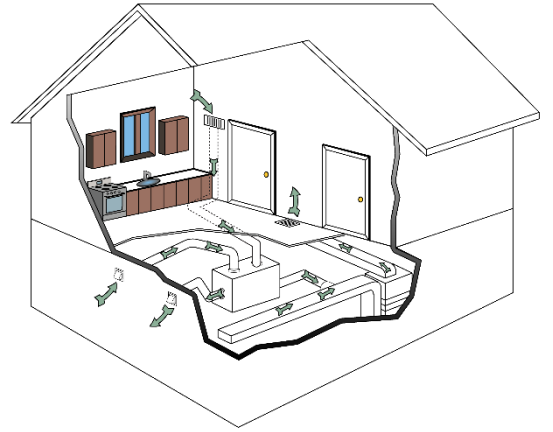

Spring-Loaded Backdraft Damper (recommended):

Install the Backdraft Damper with the leaf hinge vertical. The damper is installed on the "Stale Air to Outside Collar"

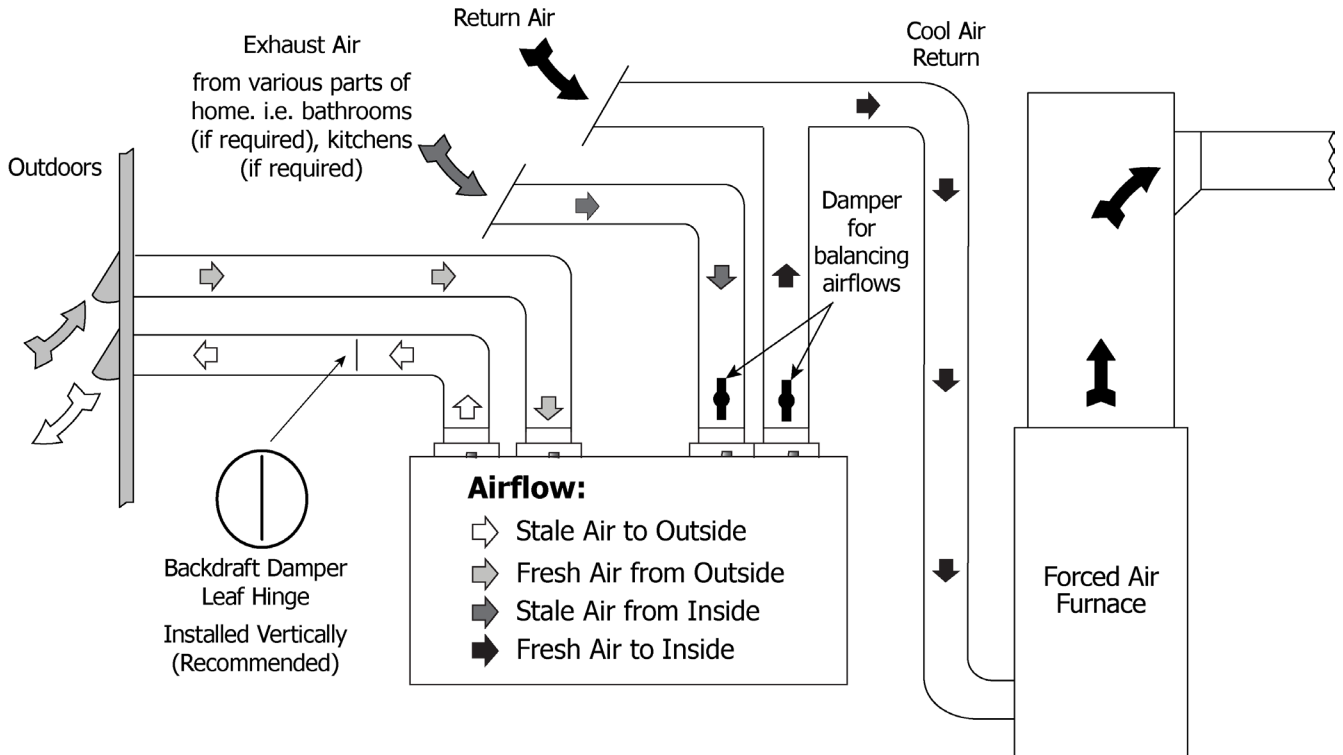

Warning

- Check local codes/authority having jurisdiction for acceptance.
- Applications such as greenhouses, atriums, swimming pools, saunas, etc. have unique ventilation requirements which should be addressed with an isolated ventilation system.
- Weatherhood arrangement is for drawing purposes only. Check local codes/authority having jurisdiction for acceptance.
- Backdraft dampers are recommended for the stale air to outside air duct. This damper prevents outdoor air from entering the ERV during the operation of the furnace/air handler while the ERV is in standby, off, or recirculating.

4 FULLY DEDICATED SYSTEM INSTALLATION

Installation Notes:

- The ERV must be balanced.
- When balancing, all external exhaust systems should be turned off (i.e. range hood, exhaust, bathroom vents).
- All exhausting appliances should have their own make-up air, as this is not an intended use for the ERV system.
- The duct configuration may change depending on the ERV model.
- The airflow must be confirmed on site using the balancing procedures found in this guide.

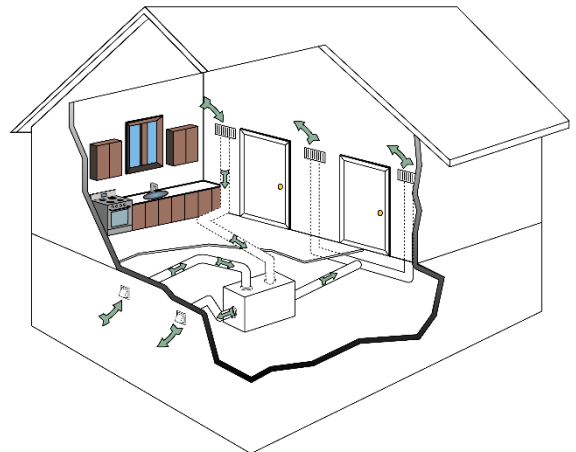

Spring-Loaded Backdraft Damper (recommended):

There is a location for an optional Backdraft Damper with the leaf hinge vertical. The damper is installed on the "Stale Air to Outside Collar"

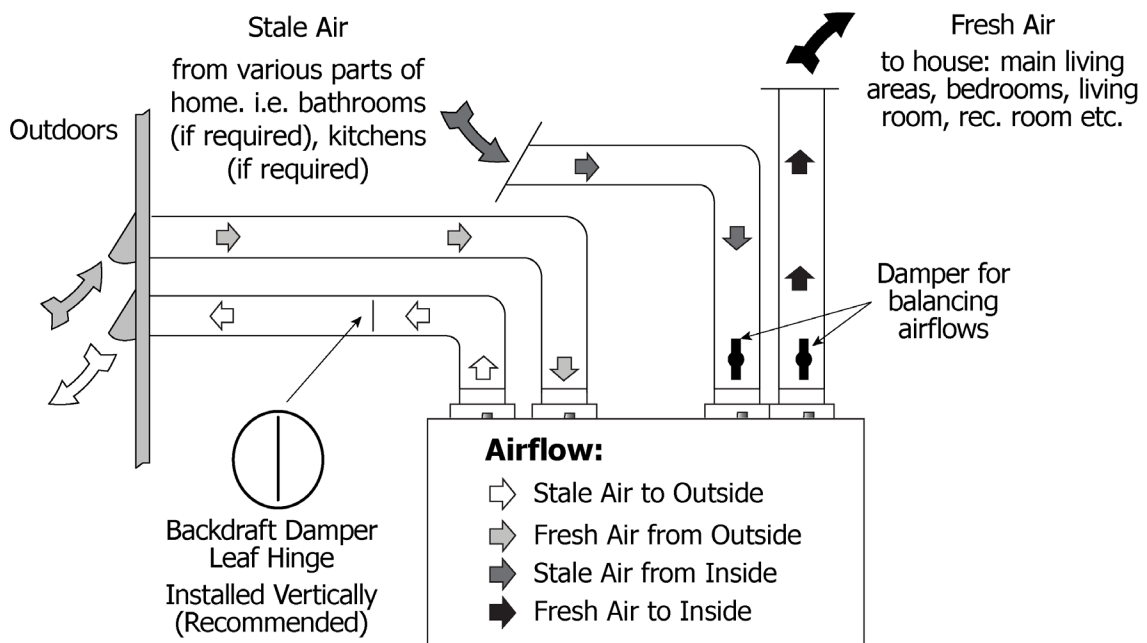

Warning

- Check local codes/authority having jurisdiction for acceptance.
- Applications such as greenhouses, atriums, swimming pools, saunas, etc. have unique ventilation requirements which should be addressed with an isolated ventilation system.
- Weatherhood arrangement is for drawing purposes only. Check local codes/authority having jurisdiction for acceptance.
- Backdraft dampers are recommended for the stale air to outside air duct. This damper prevents outdoor air from entering the ERV during the operation of the furnace/air handler while the ERV is in standby, off, or recirculating.

5 MOUNTING (30ERV) AND PLUGS

Mounting the 30ERV

(1) Mounting Points

1. Locate the four mounting tabs on the left and right sides of the unit, at the front and back.
2. Using a flat/pan head screwdriver, bend out the four tabs to approximately 45 degrees.
3. Once the tabs have all been bent outwards, insert the "S" hooks through the four holes on the tabs.
4. Install the unit to the structure. Refer to [Hanging Straps](#).

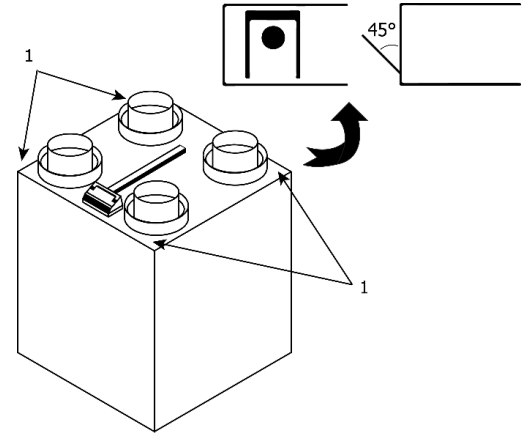

Optional Plug Installation

(1) Plugs

1. Install the plugs (from the ERV manual bag) into the 2 holes located in the bottom tray of the ERV. They must be inserted from the inside of the unit to ensure the holes are fully sealed.

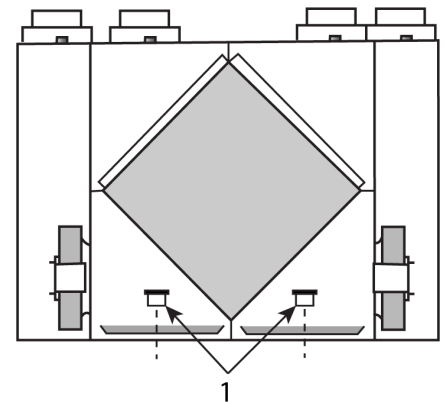

Caution

- A drain is required; however, the use of a drain is optional in climates where the outdoor temperature remains above -25°C (-13°F) combined with an indoor humidity less than 30%.



Attention

- Do not drill additional holes in the ERV

6 HANGING STRAPS

The hanging straps are designed to reduce the possibility of noise, resonance and harmonics.

Figure Callouts:

- (1) Screws (not included)
- (2) Washers (not included)
- (3) Hanging Strap Grommets
- (4) Structure
- (5) Machine Screws
- (6) "S" Hooks
- (7) Hand Loops

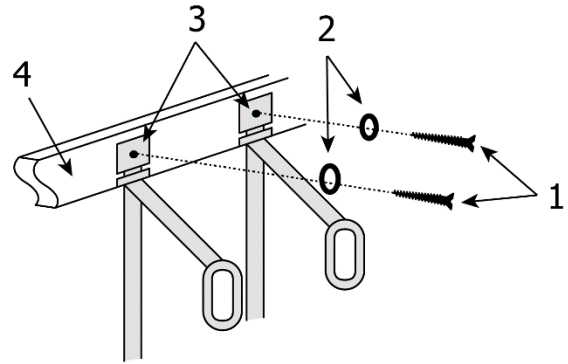

Installation Steps:

1. Insert 4 screws and 4 washers (not included) through the hanging strap grommets. Fasten to the structure.
2. Remove the 4 machine screws located on the upper side of the unit. Attach the "S" hooks and reinsert the machine screws.
3. Hook the bottom grommets of the straps through the "S" hooks. Pull down vertically on the hand loops while lifting the bottom of the unit.
4. Level the unit from right to left to right and front to back. Adjust the unit up by pulling down vertically on the hand loops while lifting on the bottom of the cabinet.
5. Fold the excess strap of the hand loops and secure with a nylon tie.

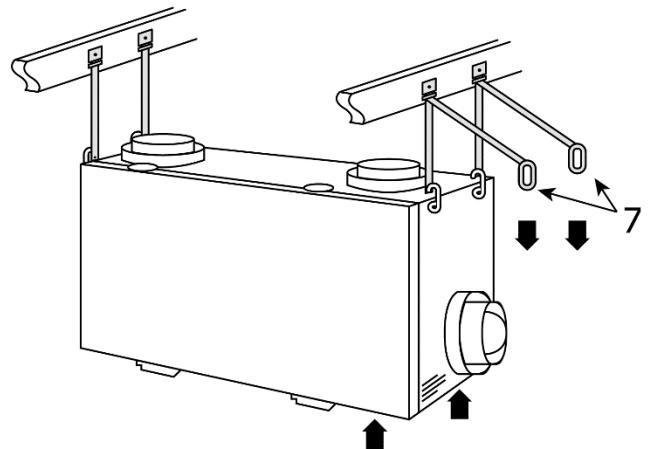
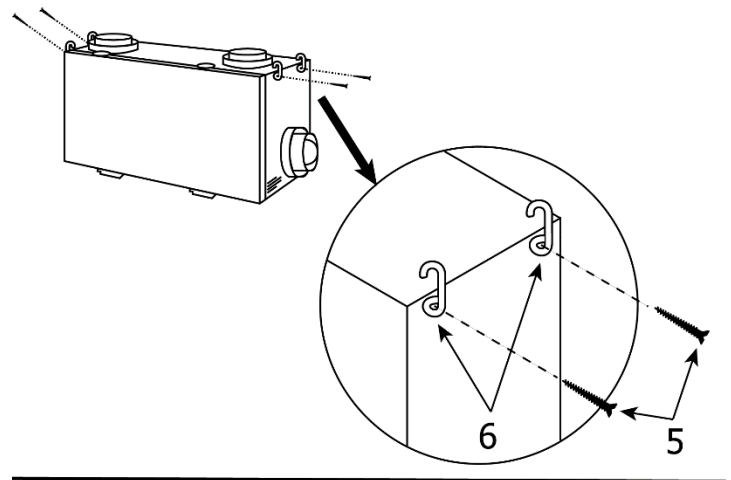

Attention

- The washer must be wider than the eyelet of the grommet on the hanging strap.
- Must push up on the bottom of the ERV when pulling the hanging straps.
- The unit must be mounted level for proper drainage of the condensate pans.

7 DRAIN CONNECTION

The ERV cabinet has pre-punched holes for the drain. The ERV may produce some condensation during a defrost cycle. This water should flow into a nearby drain or be taken away by a condensate pump.

Figure Callouts:

- (1) Drain Spout
- (2) Drain Pan
- (3) Drain Spout Nut
- (4) Tee Connector
- (5) 1/2 in. Drain Hose
- (6) Drain Line
- (7) Zip Tie

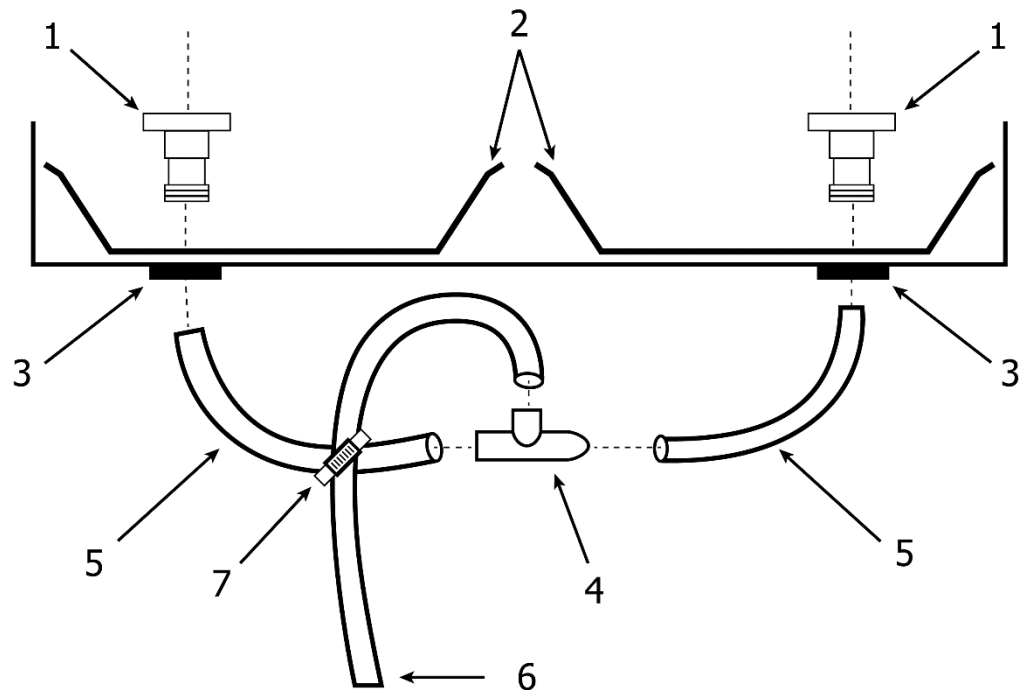

Installation Steps:

1. Insert the drain spout through the hole in the drain pan.
2. Install nut and washer on the drain spout.
3. Construct a P-trap using the plastic tee connector. Tighten the nut.
4. Cut two lengths of 1/2 in. drain hose (not included) and connect the ends to the two drain spouts and the other ends to the plastic tee connector.
5. Position the tee connector to point upward and connect the drain line. Use a zip tie to secure the drain line to one of the 1/2 in. drain hoses.
6. Tape or fasten base to avoid any kinks.
7. Pour a cup of water into the drain pan of the ERV after the drain connection is complete. This creates a water seal which will prevent odours from being drawn up the hose and into the fresh air supply of the ERV.



Caution

- A drain is required. However, the climates where the outdoor temperature remains above -25°C (-13°F) combined with an indoor humidity less than 30%, the use of a drain is optional.
- The ERV and all condensate lines must be installed in a space where the temperature is maintained above the freezing point or freeze protection must be provided.
- Drain trap and tubing must be below bottom of door with 1/4 in. per foot downwards slope away from unit.
- Under certain conditions, a secondary drain pan may be required to protect from condensate leakage.

8 GRILLES

Installation Notes:

Adjustable grilles should be used to balance the flow rates into and out of various rooms. The grilles should not be adjusted after balancing the unit.

Grilles or diffusers should be positioned high on the wall or in the ceiling. Kitchen exhaust should never be connected to the range hood. They should be installed at least 4 ft (1.2 m) horizontally away from the stove.

Field supplied balancing dampers should be installed external to the unit to balance the amount of stale air being exhausted with the amount of fresh air being brought into the house. Refer to airflow balancing section.

The Kitchen Grille

The Kitchen Grille includes a removable grease filter. Most building codes require that kitchen grilles are equipped with washable filters.

- Part# 99-10-002, 6 in x 10 in

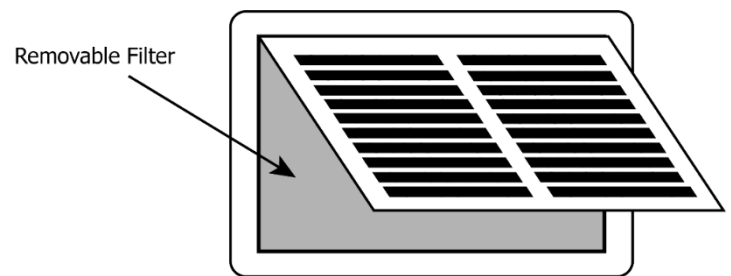

The TechGrille

The TechGrille is a round, fully adjustable grille, which provides quiet air distribution.

- Part # 99-EAG4, 4 in (100 mm)
- Part # 99-EAG5, 5 in (125 mm)
- Part # 99-EAG6, 6 in (150 mm)
- Part # 99-EAG8, 8 in (200 mm)

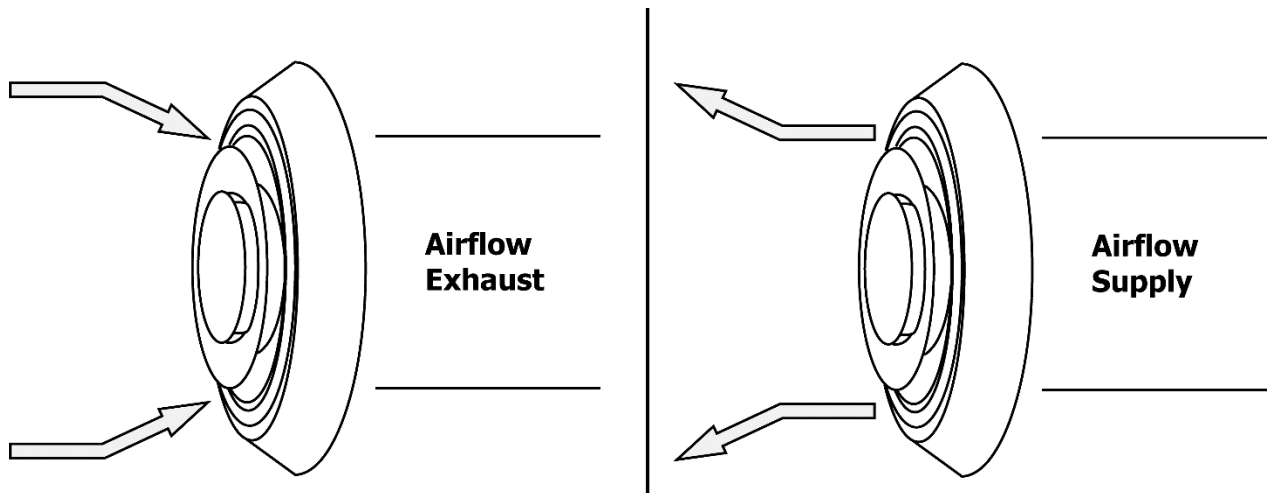

9 GRILLE FITTINGS

Quick Mount Fitting (Part# 99-QM6)

- Use this rough-in fitting before the drywall is installed.
- Nail fitting onto the stud.
- Available size: 6 in.

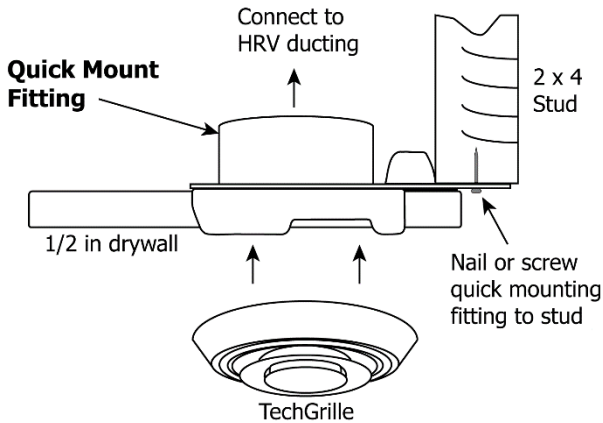

Terminator Fitting (Part# 99-TM 4/5/6)

- Use this rough-in fitting before the drywall is installed.
- Nail or screw fitting onto the stud or joist.
- Available sizes: 4 in, 5 in, and 6 in.
- Adapts to ridged and flex ducting
- Strong attachment for grilles, either vertically or horizontally.

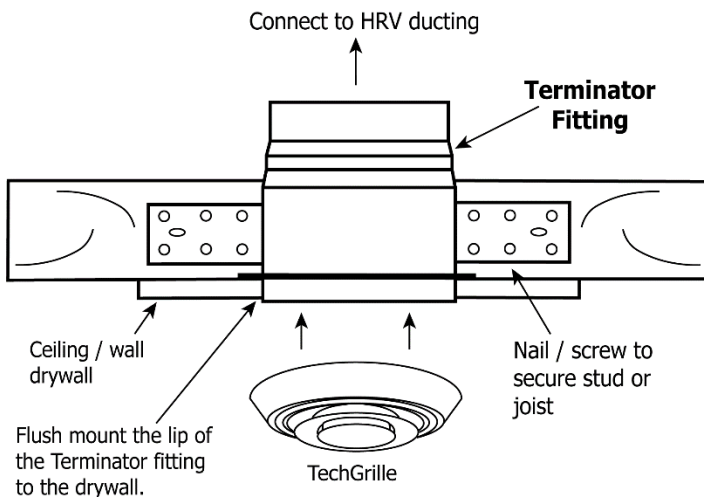

Stack Head Elbow (Part# 99-WF 4/6)

- Use this rough-in fitting before the drywall is installed.
- This fitting is ideal for running ducting through 2 x 4 (min.) studded walls.
- Nail to stud.
- Available sizes are 4 in. and 6 in.

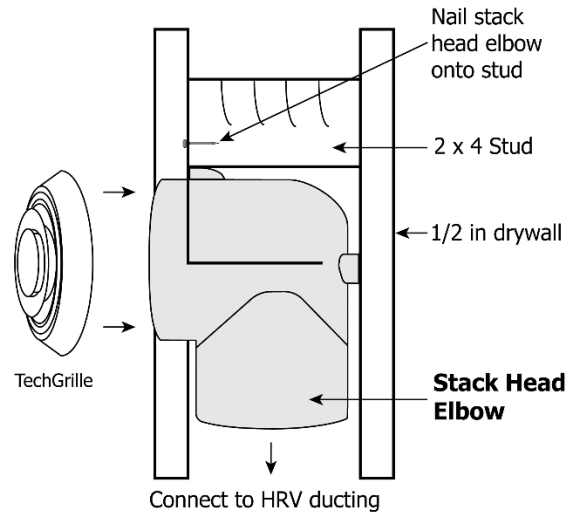

Suspended Ceiling Fitting (Part# 99-CF6)

- Use this fitting for ceiling tiles or finished/installed drywall.
- Cut a hole through the ceiling tile, insert the fitting and use the retaining ring to hold the fitting in place.
- For finished/installed drywall, use caulking around the lip if you do not have access to attach the retaining ring.
- Available size: 6 in.

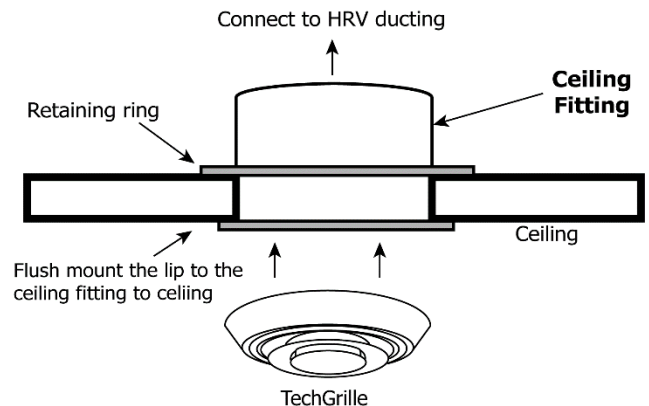

Caution

- Do not mount exhaust grille within 4 ft (1.2 m) (horizontally) of a stove to prevent grease from entering the unit.

10 LIFE BREATH WEATHER HOODS

Fixed covered weather hoods have a built-in bird screen with a 1/4 in. (6 mm) mesh to prevent foreign objects from entering the ductwork.

Installation Notes:

- The inner and outer liners of the flexible insulated duct must be clamped to the sleeve of the weatherhoods (as close to the outside as possible) and the appropriate port on the ERV. It is very important that the fresh air intake line be given special attention to make sure it is well sealed. A good bead of high-quality caulking (preferably acoustical sealant) will seal the inner flexible duct to both the ERV port and the weatherhood prior to clamping.
- The flexible insulated duct that connects the two outside weatherhoods to the ERV should be stretched tightly and be as short as possible to minimize air flow restrictions.
- Twisting or folding the duct will severely restrict airflow.
- Hard (rigid) ducting which has been sealed and insulated should be used for runs over 10 ft (3.3 m). Refer to your local building code.

Figure Callouts:

- (1) Thermal Collar
- (2) 12 in. long Galvanized Sleeve
- (3) Exterior Wall
- (4) 1/4 in. (6mm) Mesh Screen

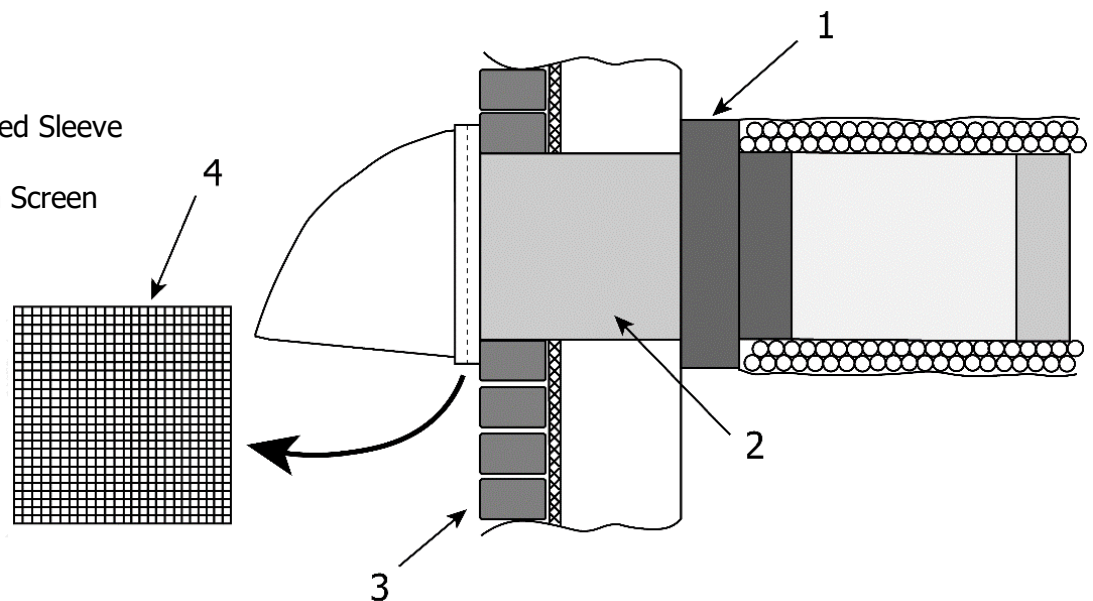

Installation Steps:

1. Thermal collar slides over galvanized sleeve to ensure vapor barrier is 100% sealed to wall plate.
2. Fasten thermal collar to belt.
3. Slide the insulated flexible ducting over galvanized sleeve and fasten it to the thermal collar.
4. Weatherhood is hinged to allow for easy access for cleaning of mesh screen.



Attention

- **Weather Hood Requirements:** Check local codes/authority having jurisdiction for acceptance and space requirements for weatherhoods. Do not locate in garage, attic, or crawl space.
 - i) **Intake:** Should be located upstream (if there are prevailing winds) from the exhaust outlet. Not near dryer vents, furnace exhaust, driveways, oil fill pipes, gas meters, or garbage containers.
 - ii) **Exhaust:** Not near a gas meter, electric meter or a walkway where fog or ice could create a hazard.

11 LIFE BREATH DUAL HOOD

The Lifebreath Dual Hood only requires one 6 in. opening for intake and exhaust. The Lifebreath Dual Hood can be used up to a maximum airflow of 140 cfm.

Available Units:

- 99-194 – 4 in. Dual Hood (not shown)
- 99-190 – 5-6 in. Dual Hood

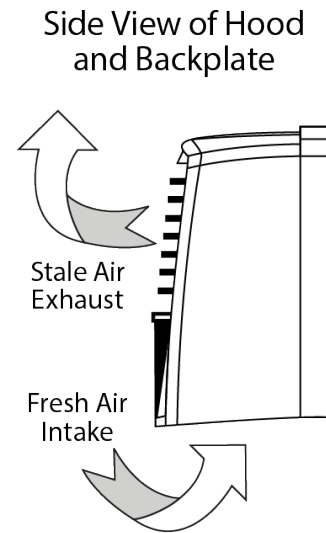
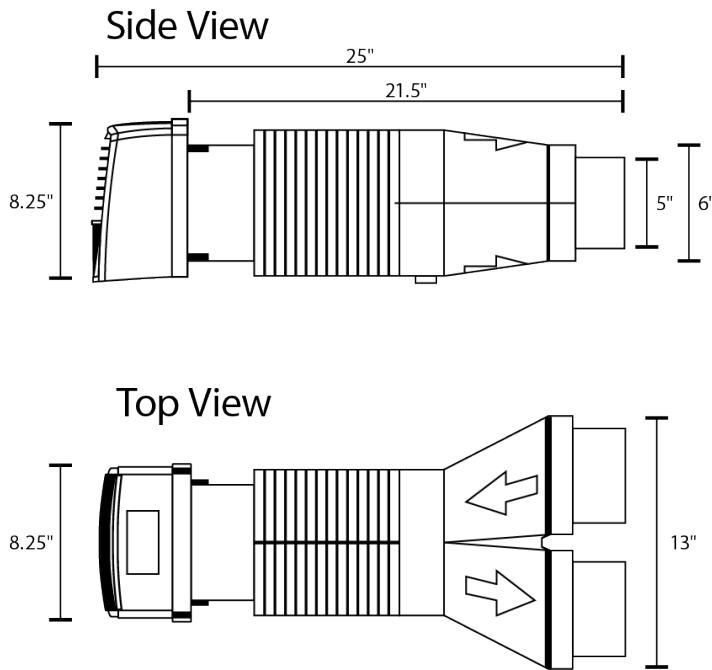

Caution

- Sealant must be applied as per instructions or leakage and condensation may occur.
- Insulate the Fresh Air Supply and Stale Air Exhaust duct work back to the unit.

Attention

- Contact your local building authority before installation of the Dual Hood to verify compliance with local building codes.

Note

- Tested by: National Research Council Canada
- Program: Building Regulations for Market Access Report Number: A1-007793
- Report Date: 15 February 2016
- Found to comply with requirement as set in the NBC.

12 MAIN CONTROL INSTALLATION (99-DXPL02 / 99-DXPL03)

The 99-DXPL02 wall control must be surface mounted onto a wall. Only one main control should be installed into a ventilation system.

Installation:

1. Remove the operating instructions card from the top of the main control (figure A).
2. Carefully separate the face plate and the back plate by firmly pulling it apart (figure A).
3. Position the back plate of the control in the desired location on the wall and mark the wall for the desired screw holes (figure B).
4. Remove the back plate from the wall and mark the hole for the wires in between the two screw holes (figure B).
5. Drill two holes for the screws and wall anchors and drill one hole for the wires in between the two screw holes (figure B).
6. Pull the 3 wire 20 gauge (min.), 100 ft length (max.), through the opening in the wall.
7. Connect the wires to the R, G, and Y terminals on the back plate (figure B).
8. Using the two supplied screws and anchors, install the back plate on the wall.
9. Attach the face plate to the back plate (figure A).
10. Install the operating instructions card in the top of the main control (figure A).

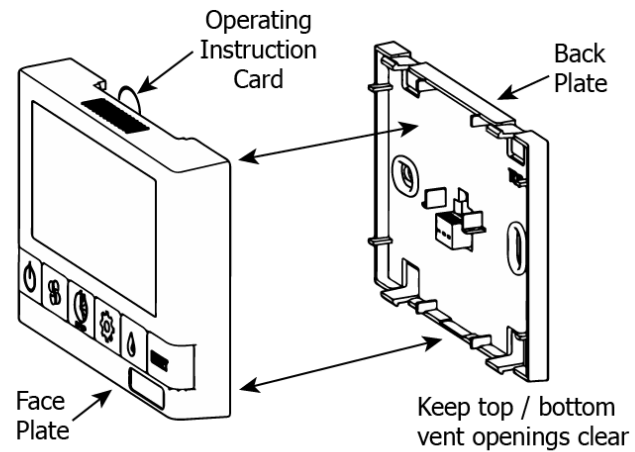

Figure A

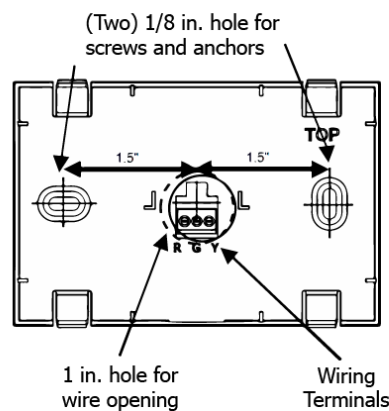

Figure B

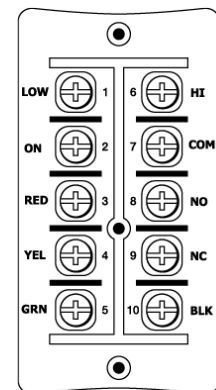

Figure C

11. Connect the 3 wires 20 gauge (min.), 100 ft length (max.), to the 3 (RED), 4 (YEL), and 5 (GRN) terminals located on the ERV terminal block (figure C).



Attention

- Use care when separating or attaching the face plate to avoid damaging the contact pins.

13 MAIN CONTROL INSTALLATION (99-BC02, -BC03, -BC04)

The 99-BC02, 99-BC03, 99-BC04 ventilation controls may either be installed onto a flush mounted electrical switch box or surface mounted onto a wall. Only one main control should be installed into a ventilation system.

Installation:

1. Carefully separate the face plate and the back plate by firmly pulling it apart. Keep the top/bottom vent openings clear (figure A).
2. Position the back plate in the desired location on the wall and mark the wall for the desired screw holes (figure B).
3. For mounting the main control without a Decora plate, break off the top and bottom tabs than position the back plate in the desired location on the wall and mark the wall for the desired screw holes (figure C)

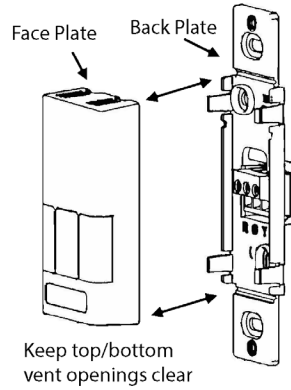

Figure A

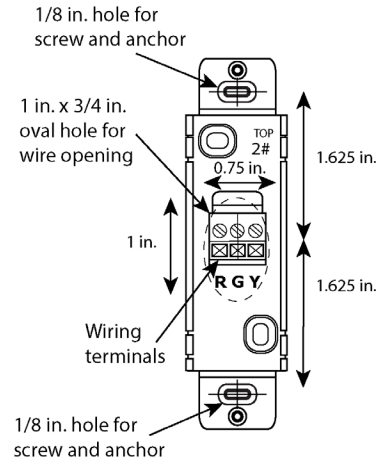

Figure B

4. Remove the back plate from the wall and mark the hole for the wires centered between the two screw holes (figure B or C).
5. Drill two 1/8 in. holes for the screws and wall anchors and drill one 1 in. x 0.75 in. hole for the wires.
6. Pull the 3 wire 20 gauge (min.), 100 ft length (max.), through the opening in the wall.
7. Connect the wires to the R, G, and Y terminals on the back plate (figure B or C).
8. Using the two supplied screws and anchors, install the back plate on the wall.
9. Attach the face plate to the back plate (figure A).
10. Connect the 3 wires 20 gauge (min.), 100 ft length (max.), to the 3 (RED), 4 (YEL), and 5 (GRN) terminals located on the ERV terminal block (figure D).

Alternate Wall Mount

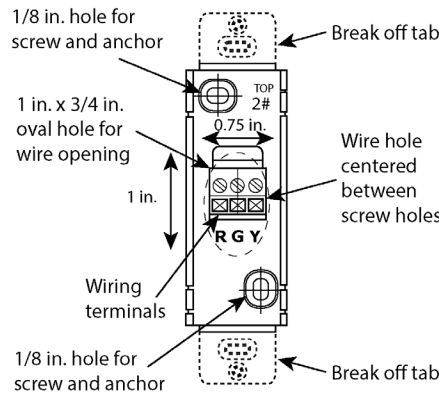

Figure C

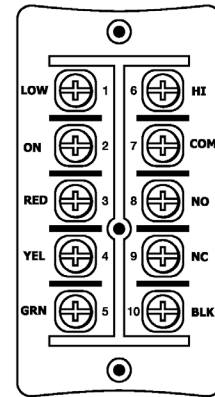

Figure D

Attention

- Use care when separating or attaching the face plate to avoid damaging the contact pins.

14 INTERLOCKING THE ERV

Interlocking the ERV to an Air Handler or Furnace Blower

Connecting the ERV as shown below will ensure that the air handler/furnace blower motor is operating whenever the ERV is venting.

- The ERV must be interlocked to the furnace/air handler with a [Simplified Installation \(Return/Return Method\)](#).
- The ERV should be interlocked to the furnace/air handler with a [Partially Dedicated System Installation](#).

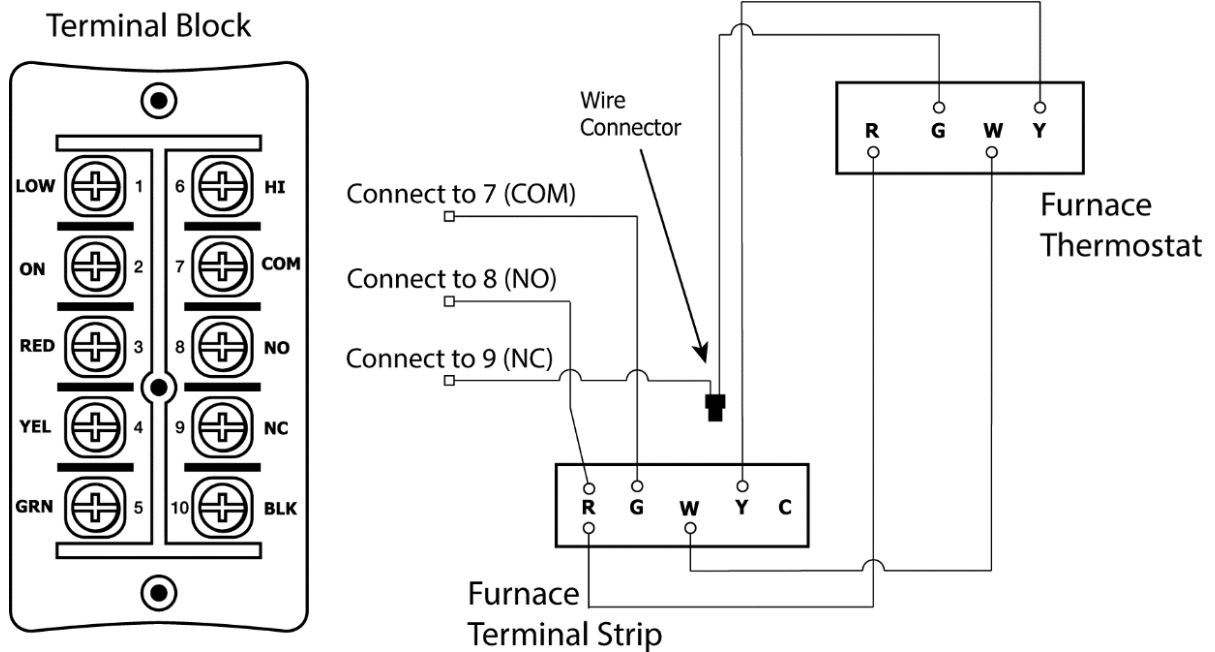

Caution

- Consideration should be given to competing airflows when connecting the ERV in conjunction with an air handler/ furnace blower system.

15 ADDITIONAL CONTROLS

Setting "Standby" When Using the Main Control

The ERV will be "fully-off" when selected on the main control. Timers and/or other controls will not function when the ERV is in off position.

The "fully-off" feature can be modified to "standby-off" by adding a jumper on the ERV terminal block between 2 (ON) and 3 (RED) terminals. "Standby" can also be achieved by setting the main control to the on position and selecting speed 0. Timers and/or additional controls will initiate high speed ventilation when activated.

———— Jumper Wire

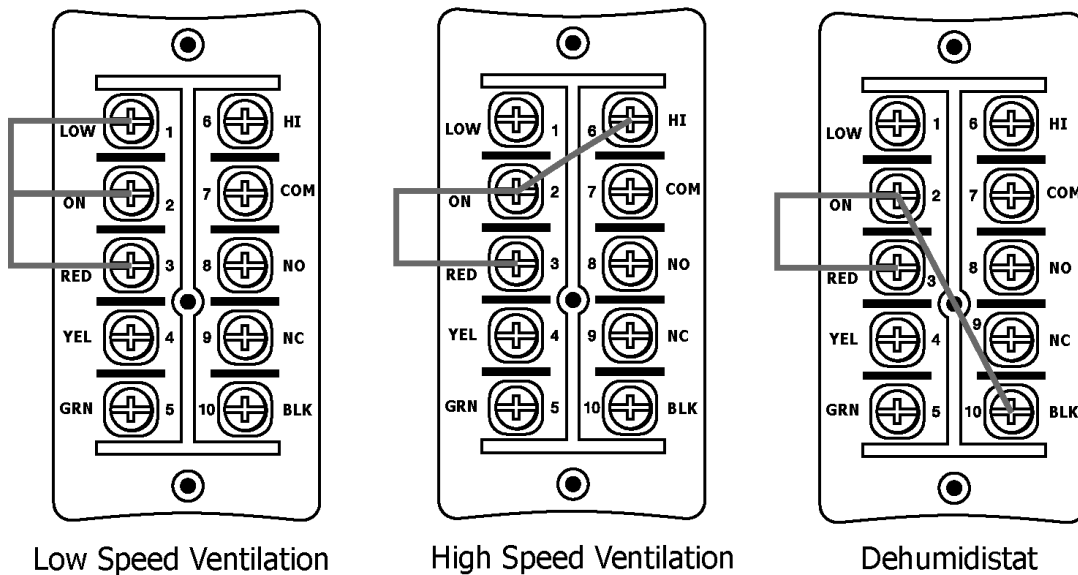

Adding Dry Contact Controls

A jumper must be placed between 2 (ON) and 3 (RED) terminals on the ERV terminal block to activate the ERV for timers and/or dry contact controls, or if installing the unit without a main control. Jumpers can be added between terminals on the ERV terminal block for additional controls, per the table below:

Setting	Terminals	
Low Speed Ventilation	2 (ON)	1 (LOW)
High Speed Ventilation	2 (ON)	6 (HI)
Dehumidistat	2 (ON)	10 (BLK)



Caution

- Building codes in some areas require "fully-off" functionality. Check with your local building authority before modifying the unit to "standby-off". Unintentional operation of the ERV by the end user may occur if the unit is modified from "fully-off" to "standby-off".

16 TIMERS

20/40/60 Minute Timer Installation (99-DET01)

Connect the wires from the Y, R, and G terminals on the timer to the 4 (YEL), 3 (RED), and 5 (GRN) terminals on the HRV terminal block as shown. A jumper between Red and On is required when not using a de-humidistat.

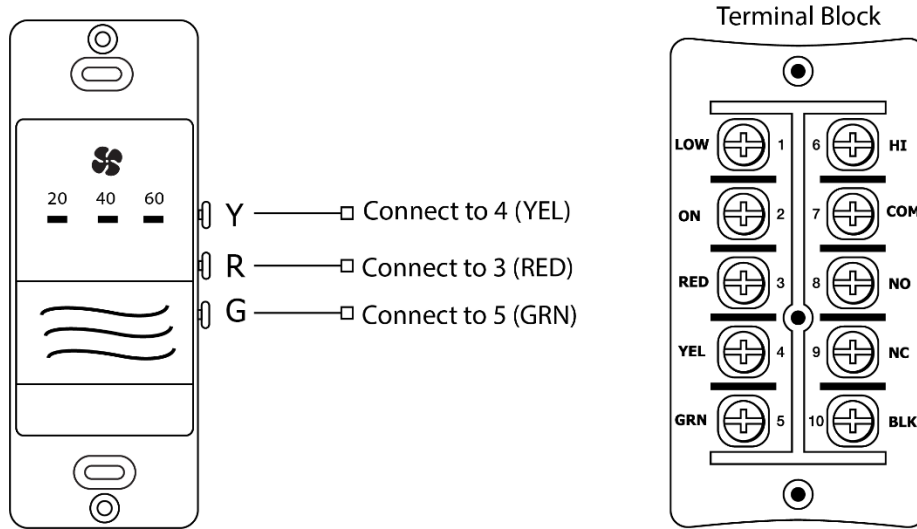

Mechanical Timers Installation (99-101)

The Mechanical Timer is a 2 wire “dry contact” timer. Connect a jumper wire between the 2 (ON) and 3 (RED) terminals on the ERV terminal block and connect the two timer wires to the 2 (ON) and 6 (HI) terminals on the ERV terminal block as shown.

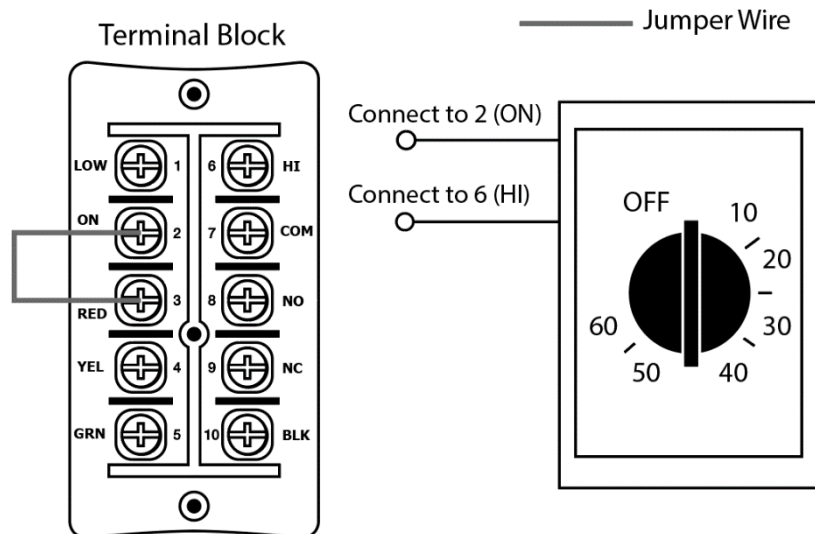

Attention







- Timers mount in standard electrical boxes.
- Use 3 wire 20 gauge (min.) 100 ft length (max.) low voltage wire and multiple timers individually wired back to the unit.

16 TIMERS

Wireless 20/40/60 Minute Timer (99-DET02)

The timers may be installed onto a flush mounted electrical switch box or it may be surfaced mounted onto a wall.

Pairing:

1. Remove the battery from the back of the timer, if installed.
2. Press the ON/OFF Button  on the main control to turn it on.
3. **DXPL02, DXPL03:** Press the left and right buttons ( and RESET) simultaneously on the main control. The screen will go blank and the wireless symbol  will appear flashing on the bottom right of the display. This indicates that the main control is now in pairing mode.
4. **BC02, BC03, or BC04:** Press the left and right buttons ( and  or ) simultaneously on the main control. The bottom row LEDs will begin flashing. This indicates the main control is now in pairing mode.
5. Keep the timer within 16 in. of the main control when pairing.
6. Install the battery into the remote timer. The four lights will immediately flash five times. The red battery light will remain on for 12 seconds, then the 40 minute status light will flash. The 20, 40, and 60 minute status lights will flash for up to 30 seconds and then stop.
7. Press the Power Button  on the main control to exit pairing mode.
8. Press the Select Button on the timer to test that pairing was successful (figure A).
 - If the ERV initiates HIGH fan speed ventilation, pairing was successful.
 - If the ERV does not initiate HIGH fan speed ventilation, pairing was not successful. Un-pair the timer and return to step 1 of the pairing procedure and restart the pairing process.
9. Pair additional timers as necessary by repeating steps 1 through 8.

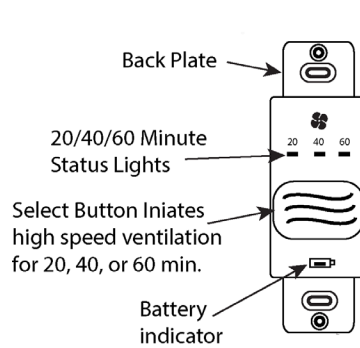

Figure A

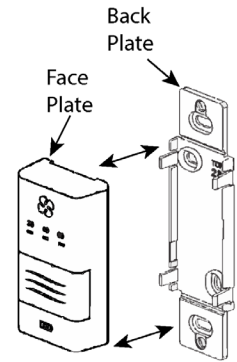

Figure B

Alternate Wall Mount

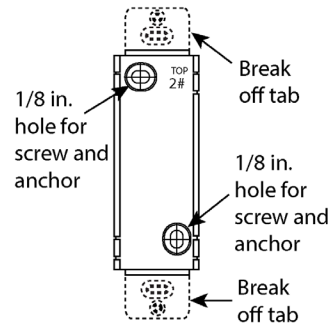

Figure C

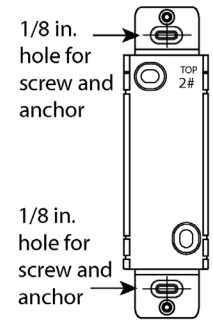

Figure D

Un-pairing:

1. Remove the battery from the back of the timer.
2. Press and hold the Select Button on the front of the timer (figure A).
3. While holding the Select Button, reinstall the battery in the timer. Continue holding the Select Button until the 20, 40, and 60 minute status light begins flashing (this can take up to 30 seconds). The timer will now be unpaired with the main control (figure A).

Installation:

1. Separate the face plate from the back plate by firmly pulling apart (figure B).
2. For mounting the main control without a Decora plate, break off top and bottom tabs (figure C).
3. Place the back plate of the main control in the desired location on the wall and pencil mark the top and bottom screw holes. Drill two 1/8" holes (figure C or D).
4. Attach the back plate to the wall using the two supplied screws and anchors.
5. Attach the face plate to the back plate (figure B).

Attention

- The wireless timers and repeaters must be paired to the main control of the ERV. This process is called "Pairing". Multiple timers and repeaters can be paired to the main control.

17 REPEATERS

99-RX02 Repeater

- (1) Green LED
- (2) Red LED
- (3) Power Plug

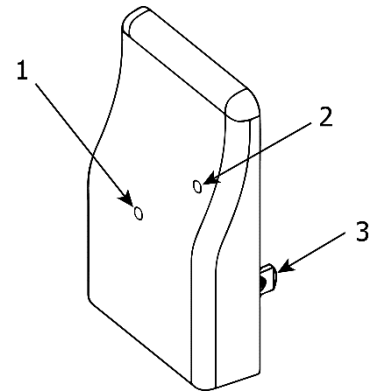







The wireless repeater is used to extend the range of the 99-DET02 wireless timers. The repeater plugs directly into a 120V power outlet. The 99-RX02 repeater wirelessly connects to the main wall control as well as the 99-DET02 wireless timers.

The 99-RX02 repeater should be installed at the halfway point between the 99-DET02 wireless timer and the main wall control if the timer is out of range. The LED will indicate the repeater's connection strength to the main wall control per the table below. Re-adjust the repeater's position as necessary.

LED Colour	Connection	Action
Solid Green	Good	No further adjustments are required.
Flashing Green	Moderate	The repeater will function properly but shouldn't be moved further away from the main wall control.
Red	Bad	The repeater needs to be moved closer to the main wall control.

Pairing:

1. Turn on the main control by pressing the ON/OFF button .
2. **DXPL02, DXPL03 control:** Press the left and right buttons simultaneously on the main control ( and RESET). The screen will go blank and the wireless symbol will appear flashing on the bottom right of the display. This indicates that the main control is now in pairing mode.
3. **BC02, BC03 or BC04 control:** Press the left and right buttons simultaneously on the main control ( and  or ). The bottom row LED's will begin flashing. This indicates that the main control is now in pairing mode.
4. The RX02 Repeater must be powered within 16 in. of the main control for pairing. If an outlet is not available an extension cord should be used to power the Repeater initially for pairing.
5. Plug the repeater into the power outlet. The green light will flash after approximately 12 seconds indicating that the repeater is paired with the main control.
6. Press the ON/OFF button  on the main control to exit pairing mode and the repeater may now be unplugged and moved to its permanent location.
7. To pair additional repeaters with the same main control, repeat steps 1 through 5 until all repeaters have been paired.



Attention

- The repeaters are to be plugged directly into a 120V power outlet.

18 INSTALLER SELECTABLE HIGH-SPEED SETTINGS

Installer selectable high speed settings

The circuit board on the units have adjustable DIP switches to select the maximum air flow at high speed. Adjusting high speed can be useful to accurately satisfy the calculated ventilation rate. The table below indicates how to adjust high speed to speed 4 (Hi 2) and speed 3 (Hi 1). Refer to the specification pages in the manual for the air flow rates for speeds 5, 4 and 3. The factory setting is speed 5 (Hi 3).

DIP Switch settings

Applicable Units: 30 ERV, 130 ERVD, 170 ERVD

Speed	Switch			
	1	2	3	4
Hi 3 (High Speed)	ON	Leave on factory setting	ON	ON
Hi 2 (Med Speed)	ON	Leave on factory setting	OFF	ON
Hi 1 (Low Speed)	ON	Leave on factory setting	ON	OFF

Note: Low Speed is not adjustable; Switch 1 Factory Setting is ON

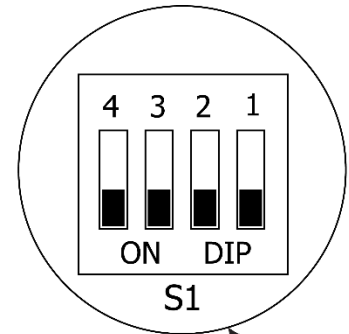

Functionality of DIP Switches

Switch	Status	Description
2	ON	Recirculation enabled
	OFF	Recirculation disabled

Note: Recirculation is not available on all units.

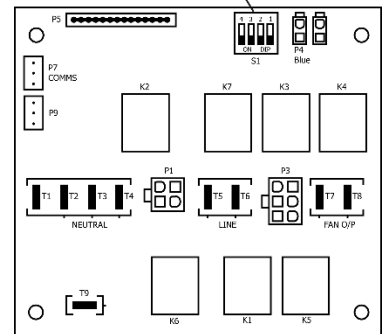

Applicable Units: 267 MAX ERV, 267 MAX ERV-FID

Dip Switch Orientation for 267 MAX ERV								
Speed	SWITCH 2				SWITCH 1 *			
	1	2	3	4	1*	2*	3*	4*
Hi 3 (Speed 5)	ON	ON	ON	ON	OFF*	ON*	OFF*	OFF*
Hi 2 (Speed 4)	ON	ON	OFF	ON				
Hi 1 (Speed 3)	ON	ON	ON	OFF				
*Leave on Factory Setting								
Switch 2: Dip 1 On - R2000 Defrost cycle disabled Dip 1 Off - R2000 Defrost cycle enabled Dip 2 - Null					Switch 1: Auto balance Unit Selection			

19 DIMENSIONAL DRAWINGS

30ERV Dimensions:

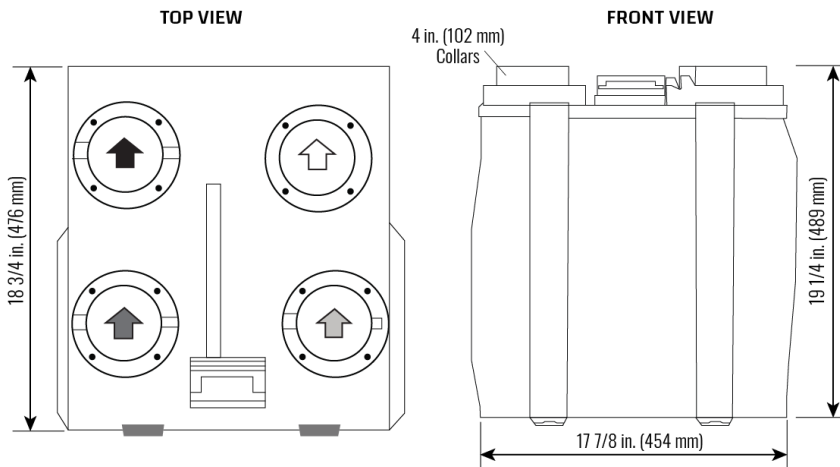

Airflow:

- ⇨ Stale Air to Outside
- ⇦ Fresh Air from Outside
- ⇨ Stale Air from Inside
- ⇦ Fresh Air to Inside

130ERVD Dimensions:

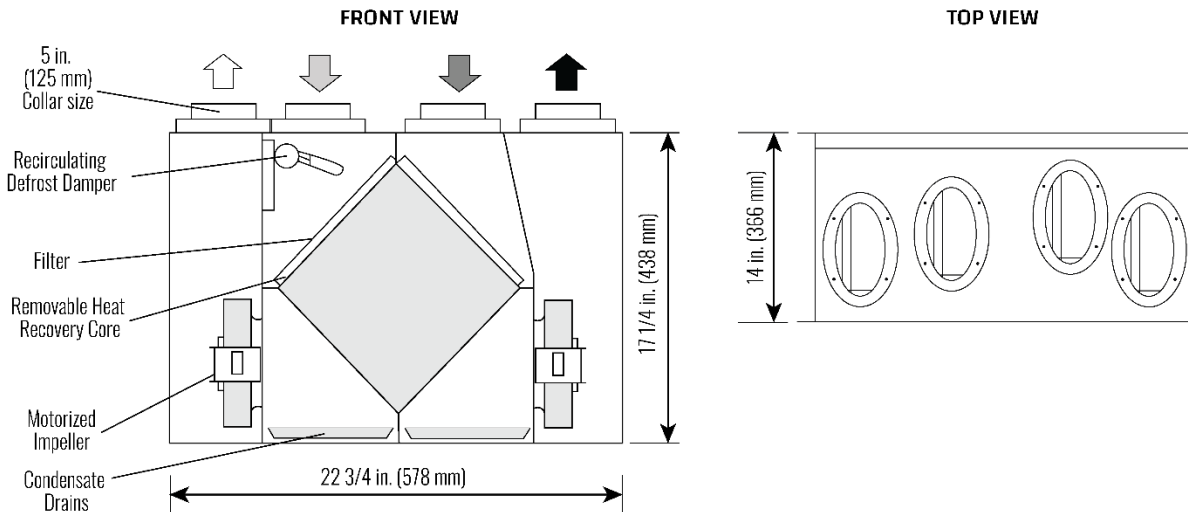

170ERVD Dimensions:

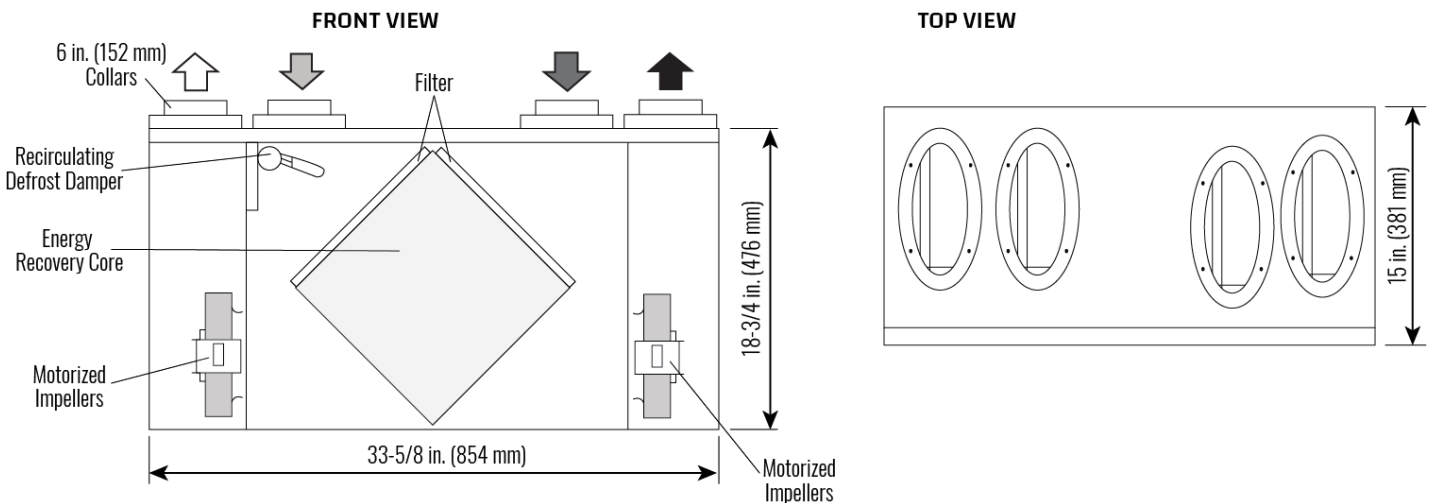

20 DIMENSIONAL DRAWINGS

267MAX ERV, 267 MAX ERV-FID Dimensions:

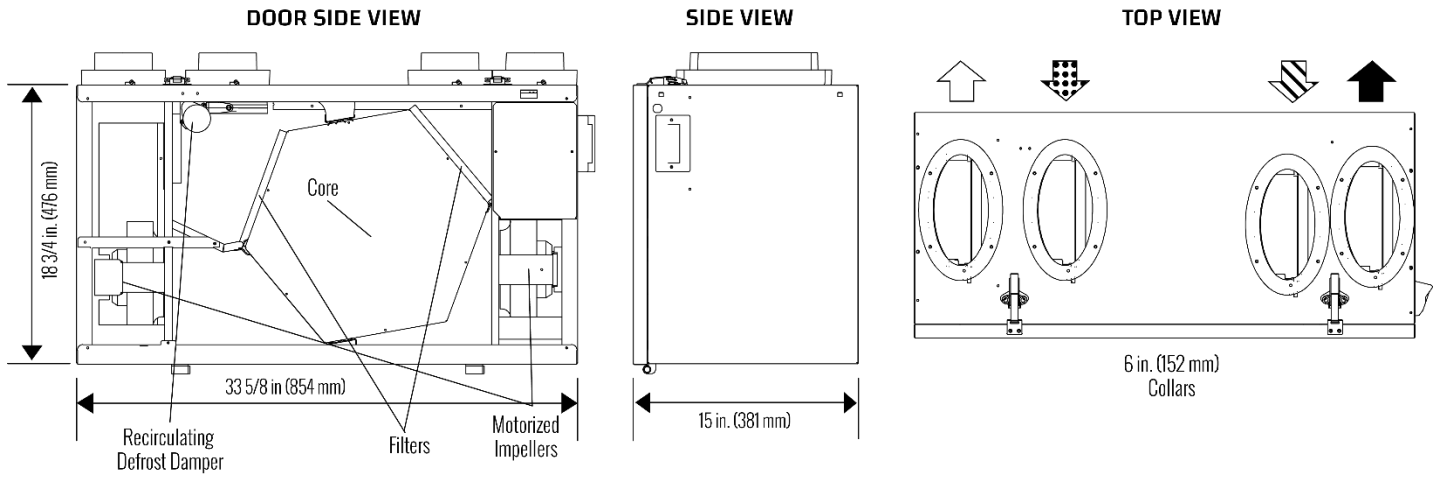

Airflow:

- ☐ Stale Air to Outside
- ▒ Fresh Air from Outside
- ▤ Stale Air from Inside
- Fresh Air to Inside

21 BALANCING THE AIRFLOWS

Balancing the airflows is critical to ensure that the amount of air coming into the building equals the amount of air exhausted to the outside of the building. If these two airflows are not properly balanced, the following issues may occur:

- A positive or negative pressure in the house
- ERV will not operate at its maximum efficiency
- ERV will not defrost properly.

Airflow Measuring Gauge:

- A digital manometer is a suitable instrument for the balancing of airflows.

Airflow Balancing Kit:

- Kit includes a digital manometer, pitot tubes, hose, and tool bag.



Airflow Balancing Kit (99-BAL-KIT)

Gauge Attachments:

When sampling an airflow, various attachments are available for use on a digital manometer. Consult with your Lifebreath distributor for available options such as a pitot tube, flow measuring station, and an airflow measuring probe. The illustration shows a digital manometer with a pitot tube attachment. This combination will measure the system air velocity pressure accurately, regardless of the duct size or shape (either round or rectangular).

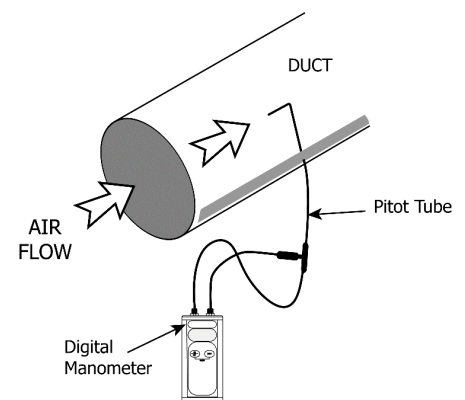

Balancing Preparation:

Prior to performing the air balancing procedure, perform the following steps:

1. Seal the ductwork.
2. Confirm the installation and proper operation of all the components of the ERV.
3. Fully open the balancing dampers.
4. Turn off all household exhaust devices (range hood, clothes dryer, bathroom fans).
5. Set the ERV at high speed.
6. Prior to balancing the unit, first adjust airflows in the branch lines to specific areas of the house.
7. If the outdoor temperature is below 0°C (32°F), ensure the unit is not running in defrost.
8. If the system is a Simplified or Partially Dedicated installation, operate the furnace/air handler at high speed.



Attention

- Continuous, excessive, positive pressure may drive moist indoor air into the external walls of the building. Once inside the external walls, moist air may condense (in cold weather) and degrade structural components or cause locks to freeze.
- Continuous, excessive, negative pressure may have several undesirable effects. In some geographic locations, soil gases such as methane and radon gas may be drawn into the home through basement or ground contact areas and may also cause the backdrafting of vented combustion equipment.

22 BALANCING THE AIRFLOWS

Determining the CFM:

After balancing the airflows, calculate the CFM flow rate.

Example

This example shows how to determine the airflow for a 6 in diameter duct. If the duct velocity pressure reads 0.025 in w.g. on the digital manometer, use the chart that came with the pitot tube to determine a duct velocity of 640 ft/min. for a duct velocity pressure of 0.025 in w.g.

CFM Calculation

$$\begin{aligned}\text{CFM} &= \text{feet per minute} \times \text{cross section area of duct} \\ &= 640 \times 0.196 \\ &= 125\end{aligned}$$

Cross section area of some common duct sizes:

Cross-Section Area	Duct Size
0.087	4 in.
0.139	5 in.
0.196	6 in.
0.267	7 in.

Units with Balancing Collars:

Install these units with the dampers fully open and damper down the duct with the higher airflow equal to the lower airflow. Refer to the "Balancing the Airflows" page found in this manual. All other units require dampers for balancing airflows installed into the "Fresh Air to Building" and "Stale Air from Building" ductwork.

Hard/Rigid Ducting

- Push and turn with slotted screwdriver. Damper automatically locks when pressure released.

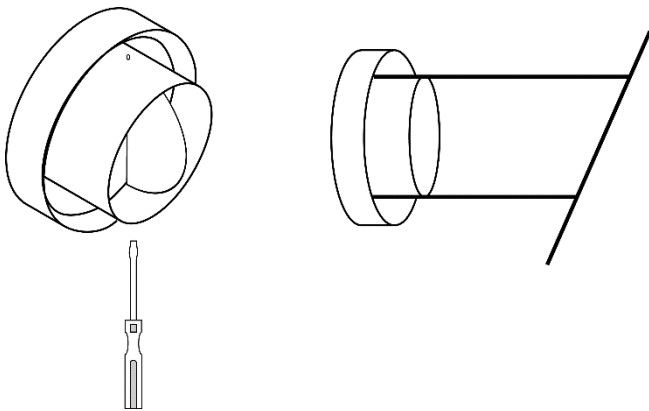

Insulated flexible ducting

- When connecting ductwork to the collar, take note where screws are located. Screws should be located no further than 1/2 in from outside edge of collar, so as not to impede operation of the damper.

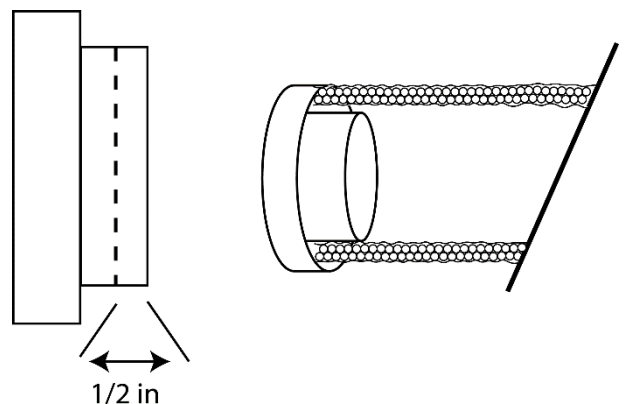

Attention

- Installations where the ERV is ducted directly to the return of a furnace may require additional dampening on the fresh air to building duct. This is due to the high return static pressures found in some furnace installations.

23 BALANCING THE AIRFLOWS – PITOT TUBE

Figure Callouts:

- (1) 3/16 in. Hole
- (2) Pitot Tube Tip
- (3) Digital Manometer
- (4) Balancing Damper

Airflow:

- ⇨ Stale Air to Outside
- ⇨ Fresh Air from Outside
- ⇨ Stale Air from Inside
- ⇨ Fresh Air to Inside

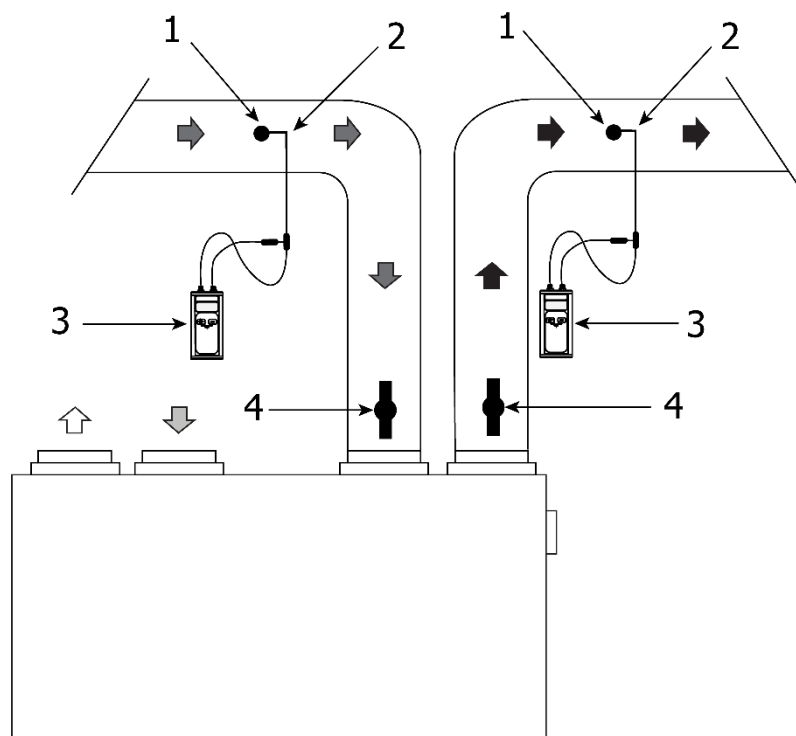

Steps:

1. Drill a 3/16 in. hole in the duct, ideally 3 ft. downstream and 1 ft. upstream of any elbows or bends in the fresh air and stale air streams.
2. Insert the pitot tube with the tip facing towards the air stream in the "Stale Air from Inside" stream. Move the pitot tube around in the duct (facing toward the airflow) and take an average reading. Record the reading.
3. Repeat Step 2 to measure the "Fresh Air to Inside" stream.
4. Review the readings and damper down the duct with the highest duct velocity pressure. Repeat Steps 2 and 3 until both ducts show identical readings. Upon completion of balancing, seal the holes with foil tape.

24 BALANCING THE AIRFLOWS – DOOR PORTS

Door balancing ports are designed to be used in the conjunction with a digital manometer to measure the stale and fresh airflows for balancing. Refer to [Door Port Locations](#) for your model to locate the door ports.

Balancing Steps:

1. Prepare the airflow measuring device by connecting the hoses to the low- and high-pressure side of the gauge.
2. Insert the hoses into suitable rubber fittings (comes with 99-BAL-KIT). Use light pressure and rotate until fitting is snug. Do not extend the hose past the rubber fitting.
3. Open the ERV door. Remove the four door port covers by carefully pushing them out from the back side of the door.
4. Close the ERV door. Initiate power and operate the ERV on high speed. Operate the forced air system on high speed (if the ERV is connected to the forced air system).
5. Insert the 2 hoses from the gauge into the exhaust balance ports. Seal the supply balance ports with tape. Record your reading. If you get a negative reading, the hoses need to be reversed.
6. Insert the 2 hoses from the gauge to the supply balance ports. Seal the exhaust balance ports with tape. Record your reading. If you get a negative reading, the hoses need to be reversed.
7. Refer to the [Airflow Charts](#) for your model on the next pages and determine the fresh air and stale airflow rates.
8. Damper down the higher airflow and repeat Steps 5 through 7 as required until both airflows are identical (balanced).
9. Remove the tape and rubber fittings and reinstall the four door port covers.

25 DOOR PORT LOCATIONS

Door Ports

- (1) Exhaust Balance Port High (+)
- (2) Exhaust Balance Port Low (-)
- (3) Supply Balance Port High (+)
- (4) Supply Balance Port Low (-)

Airflow:

- ⇨ Stale Air to Outside
- ⇨ Fresh Air from Outside
- ➡ Stale Air from Inside
- ➡ Fresh Air to Inside

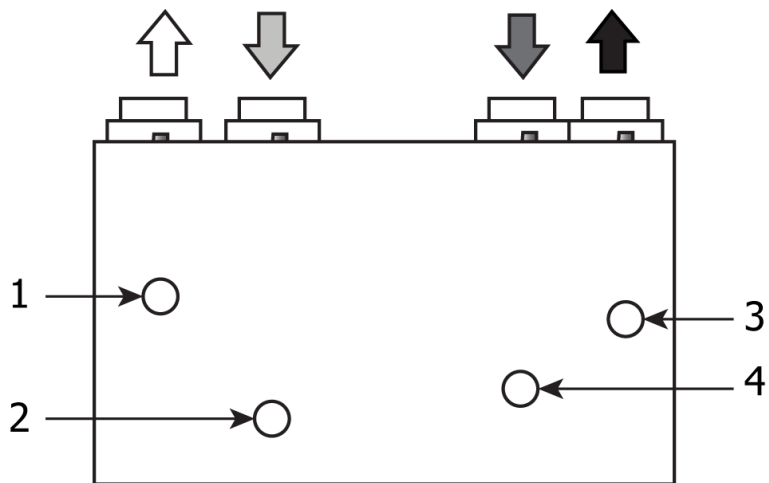

130ERV
170ERV

26 AIRFLOW CHARTS (130ERVD MODEL)

The 130ERVD units have three airflow charts for their installer adjustable fan curves. Refer to [Installer Selectable High Speed Settings](#) in this manual for instructions on how to adjust the circuit board DIP switches.

Hi 3				Hi 2				Hi 1			
Pressure Drop		Supply Airflow	Exhaust Airflow	Pressure Drop		Supply Airflow	Exhaust Airflow	Pressure Drop		Supply Airflow	Exhaust Airflow
("w.g.)	(Pa)	(cfm)	(cfm)	("w.g.)	(Pa)	(cfm)	(cfm)	("w.g.)	(Pa)	(cfm)	(cfm)
0.75	70	-	157	0.53	70	-	127	0.50	70	-	100
0.76	189	-	155	0.54	135	-	125	0.51	127	-	98
0.77	192	-	152	0.55	137	-	123	0.52	130	-	96
0.78	194	-	150	0.56	140	-	122	0.53	132	-	94
0.79	197	-	148	0.57	142	-	120	0.54	135	-	92
0.80	199	-	146	0.58	145	-	118	0.55	137	-	90
0.81	202	-	144	0.59	147	-	116	0.56	140	-	88
0.82	204	-	142	0.60	150	-	114	0.57	142	-	86
0.83	207	-	139	0.61	152	-	112	0.58	145	-	84
0.84	209	-	137	0.62	154	-	111	0.59	147	-	83
0.85	212	-	135	0.63	157	-	109	0.60	150	-	81
0.86	214	-	133	0.64	159	-	107	0.61	152	-	79
0.87	217	-	131	0.65	162	-	105	0.62	154	-	77
0.88	219	-	129	0.66	164	-	103	0.63	157	103	75
0.89	222	-	126	0.67	167	-	102	0.64	159	100	73
0.90	224	-	124	0.68	169	-	100	0.65	162	97	71
0.91	227	-	122	0.69	172	-	98	0.66	164	93	69
0.92	229	-	120	0.70	174	-	96	0.67	167	90	67
0.93	232	-	118	0.71	177	-	94	0.68	169	88	65
0.94	234	-	115	0.72	179	-	93	0.69	172	85	64
0.95	237	-	113	0.73	182	127	91	0.70	174	82	62
0.96	239	162	111	0.74	184	124	89	0.71	177	79	60
0.97	242	158	109	0.75	187	121	87	0.72	179	77	58
0.98	244	154	107	0.76	189	118	85	0.73	182	74	56
0.99	247	150	105	0.77	192	115	84	0.74	184	72	54
1.00	249	146	102	0.78	194	112	82	0.75	187	69	52
1.01	252	142	100	0.79	197	109	80	0.76	189	67	51
1.02	254	138	98	0.80	199	106	78	0.77	192	65	49
1.03	257	134	96	0.81	202	103	76	0.78	194	62	47
1.04	259	130	94	0.82	204	100	75	0.79	197	60	45
1.05	262	126	92	0.83	207	98	73	0.80	199	58	43
1.06	264	122	89	0.84	209	95	71	0.81	202	56	42
1.07	267	119	87	0.85	212	92	69	0.82	204	54	40

Continued next page ►

26 AIRFLOW CHARTS (130ERVD MODEL)

The 130ERVD units have three airflow charts for their installer adjustable fan curves. Refer to [Installer Selectable High Speed Settings](#) in this manual for instructions on how to adjust the circuit board DIP switches.

Hi 3				Hi 2				Hi 1			
Pressure Drop		Supply Airflow	Exhaust Airflow	Pressure Drop		Supply Airflow	Exhaust Airflow	Pressure Drop		Supply Airflow	Exhaust Airflow
("w.g.)	(Pa)	(cfm)	(cfm)	("w.g.)	(Pa)	(cfm)	(cfm)	("w.g.)	(Pa)	(cfm)	(cfm)
1.08	269	115	85	0.86	214	90	67	0.83	207	52	-
1.09	272	112	83	0.87	217	87	66	0.84	209	51	-
1.10	274	108	81	0.88	219	85	64	0.85	212	49	-
1.11	277	105	79	0.89	222	82	62	0.86	214	47	-
1.12	279	102	76	0.90	224	80	60	0.87	217	46	-
1.13	282	99	74	0.91	227	77	58	0.88	219	44	-
1.14	284	95	72	0.92	229	75	57	0.89	222	43	-
1.15	287	92	70	0.93	232	73	55	0.90	224	42	-
1.16	289	89	68	0.94	234	71	53	0.91	227	40	-
1.17	292	87	66	0.95	237	69	51	-	-	-	-
1.18	294	84	63	0.96	239	66	49	-	-	-	-
1.19	297	81	61	0.97	242	64	48	-	-	-	-
1.20	299	78	59	0.98	244	62	46	-	-	-	-
1.21	302	76	57	0.99	247	60	44	-	-	-	-
1.22	304	73	55	1.00	249	59	42	-	-	-	-
1.23	306	70	53	1.01	252	57	40	-	-	-	-
1.24	309	68	50	1.02	254	55	39	-	-	-	-
1.25	311	66	48	1.03	257	53	-	-	-	-	-
1.26	314	63	46	1.04	259	51	-	-	-	-	-
1.27	316	61	44	1.05	262	50	-	-	-	-	-
1.28	319	59	42	1.06	264	48	-	-	-	-	-
1.29	321	57	39	1.07	267	47	-	-	-	-	-
1.30	324	55	-	1.08	269	45	-	-	-	-	-
1.31	326	53	-	1.09	272	44	-	-	-	-	-
1.32	329	51	-	1.10	274	42	-	-	-	-	-
1.33	331	49	-	1.11	277	41	-	-	-	-	-
1.34	334	48	-	1.12	279	40	-	-	-	-	-
1.35	336	46	-	1.13	282	38	-	-	-	-	-
1.36	339	44	-	-	-	-	-	-	-	-	-
1.37	341	43	-	-	-	-	-	-	-	-	-
1.38	344	41	-	-	-	-	-	-	-	-	-
1.39	346	40	-	-	-	-	-	-	-	-	-
1.40	349	39	-	-	-	-	-	-	-	-	-

27 AIRFLOW CHARTS (170ERVD MODEL)

The 170ERVD units have three airflow charts for their installer adjustable fan curves. Refer to [Installer Selectable High Speed Settings](#) in this manual for instructions on how to adjust the circuit board DIP switches.

Hi 3				Hi 2				Hi 1			
Pressure Drop		Supply Airflow	Exhaust Airflow	Pressure Drop		Supply Airflow	Exhaust Airflow	Pressure Drop		Supply Airflow	Exhaust Airflow
("w.g.)	(Pa)	(cfm)	(cfm)	("w.g.)	(Pa)	(cfm)	(cfm)	("w.g.)	(Pa)	(cfm)	(cfm)
0.75	187	199	201	0.64	159	-	152	0.47	117	138	-
0.76	189	197	198	0.65	162	151	149	0.48	120	135	139
0.77	192	194	195	0.66	164	148	146	0.49	122	132	135
0.78	194	192	192	0.67	167	145	143	0.50	125	129	132
0.79	197	190	190	0.68	169	143	140	0.51	127	126	129
0.80	199	187	187	0.69	172	140	137	0.52	130	124	125
0.81	202	185	184	0.70	174	137	134	0.53	132	121	122
0.82	204	182	181	0.71	177	134	132	0.54	135	118	119
0.83	207	180	179	0.72	179	132	129	0.55	137	115	116
0.84	209	177	176	0.73	182	129	126	0.56	140	112	113
0.85	212	175	173	0.74	184	126	123	0.57	142	110	110
0.86	214	172	170	0.75	187	124	120	0.58	145	107	107
0.87	217	170	168	0.76	189	121	117	0.59	147	104	104
0.88	219	168	165	0.77	192	119	115	0.60	150	102	101
0.89	222	165	162	0.78	194	116	112	0.61	152	99	98
0.90	224	163	160	0.79	197	114	109	0.62	154	97	95
0.91	227	160	157	0.80	199	111	106	0.63	157	94	92
0.92	229	158	154	0.81	202	109	104	0.64	159	92	89
0.93	232	155	151	0.82	204	106	101	0.65	162	89	86
0.94	234	153	149	0.83	207	104	98	0.66	164	87	84
0.95	237	150	146	0.84	209	101	96	0.67	167	85	81
0.96	239	148	143	0.85	212	99	93	0.68	169	82	78
0.97	242	146	140	0.86	214	96	91	0.69	172	80	76
0.98	244	143	138	0.87	217	94	88	0.70	174	78	73
0.99	247	141	135	0.88	219	92	86	0.71	177	75	71
1.00	249	138	132	0.89	222	89	83	0.72	179	73	68
1.01	252	136	129	0.90	224	87	80	0.73	182	71	66
1.02	254	133	127	0.91	227	85	78	0.74	184	69	63
1.03	257	131	124	0.92	229	83	76	0.75	187	67	61
1.04	259	129	121	0.93	232	80	73	0.76	189	65	59
1.05	262	126	119	0.94	234	78	71	0.77	192	63	56
1.06	264	124	116	0.95	237	76	68	0.78	194	61	54
1.07	267	121	113	0.96	239	74	66	0.79	197	59	52

Continued next page ►

27 AIRFLOW CHARTS (170ERVD MODEL)

The 170ERVD units have three airflow charts for their installer adjustable fan curves. Refer to [Installer Selectable High Speed Settings](#) in this manual for instructions on how to adjust the circuit board DIP switches.

Hi 3				Hi 2				Hi 1			
Pressure Drop		Supply Airflow	Exhaust Airflow	Pressure Drop		Supply Airflow	Exhaust Airflow	Pressure Drop		Supply Airflow	Exhaust Airflow
("w.g.)	(Pa)	(cfm)	(cfm)	("w.g.)	(Pa)	(cfm)	(cfm)	("w.g.)	(Pa)	(cfm)	(cfm)
1.08	269	119	110	0.97	242	71	63	0.80	199	57	50
1.09	272	116	108	0.98	244	69	61	0.81	202	55	48
1.10	274	114	105	0.99	247	67	59	0.82	204	53	46
1.11	277	111	102	1.00	249	65	56	0.83	207	51	44
1.12	279	109	99	1.01	252	63	54	0.84	209	49	42
1.13	282	107	97	1.02	254	61	52	0.85	212	48	40
1.14	284	104	94	1.03	257	59	50	0.86	214	46	-
1.15	287	102	91	1.04	259	57	47	0.87	217	44	-
1.16	289	99	88	1.05	262	55	45	0.88	219	42	-
1.17	292	97	86	1.06	264	53	43	0.89	222	41	-
1.18	294	94	83	1.07	267	51	41	-	-	-	-
1.19	297	92	80	1.08	269	49	-	-	-	-	-
1.20	299	90	77	1.09	272	47	-	-	-	-	-
1.21	302	87	75	1.10	274	45	-	-	-	-	-
1.22	304	85	72	1.11	277	43	-	-	-	-	-
1.23	306	82	69	1.12	279	42	-	-	-	-	-
1.24	309	80	67	1.13	282	40	-	-	-	-	-
1.25	311	77	64					-	-	-	-
1.26	314	75	61					-	-	-	-
1.27	316	72	58					-	-	-	-
1.28	319	70	56					-	-	-	-
1.29	321	68	53					-	-	-	-
1.30	324	65	50					-	-	-	-
1.31	326	63	47					-	-	-	-
1.32	329	60	45					-	-	-	-
1.33	331	58	42					-	-	-	-
1.34	334	55	39					-	-	-	-
1.35	336	53	-					-	-	-	-
1.36	339	51	-					-	-	-	-
1.37	341	48	-					-	-	-	-
1.38	344	46	-					-	-	-	-
1.39	346	43	-					-	-	-	-
1.40	349	41	-					-	-	-	-

28 AUTO BALANCING

Auto balancing enables the installer to dial in precise airflow to meet design and code requirements and the units will maintain the airflows through auto balancing after they are set.

Applicable units:

267 MAX ERV, 267 MAX ERV-FID

Note: DXPL03 Control **MUST** be used for Auto Balancing

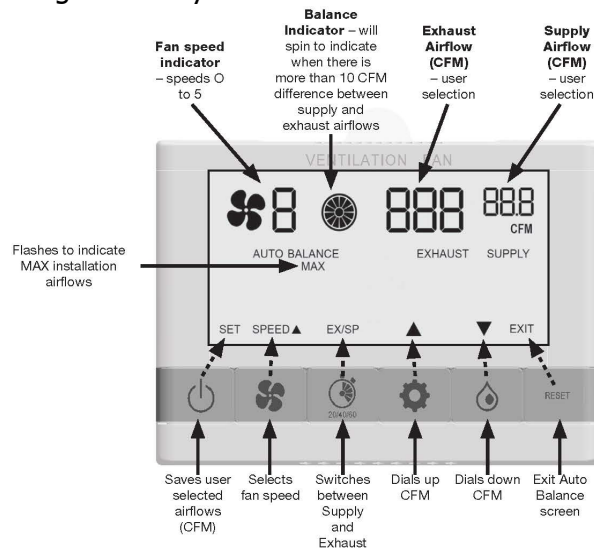

1. Power the ERV and allow Self test to complete. Self test takes approximately one minute in duration.
2. Press the power button to turn on the DXPL03 Deluxe Control.
3. Simultaneously press and hold the fan and gear buttons for 5 seconds until the screen changes and “Auto Balance” appears, then release the buttons.

Do not attempt to operate the DXPL03 Deluxe Control once the buttons are released. For approximately 15 seconds the ERV will test for its installation maximum supply and exhaust airflows. The maximum airflows will be displayed for approximately 10 seconds. “MAX” will flash during this time. Speed 5 will then be displayed and “MAX” will no longer appear on the screen. The maximum supply and exhaust airflows values (CFM) are the maximum values (CFM) that units speeds 1 to 5 can be set to. Repeat this step if “Man Balance” is shown.

4. Once speed 5 is displayed, select the airflow (supply or exhaust) to be adjusted by pressing the timer button . “SUPPLY” or “EXHAUST” will flash, indicating which airflow is selected for adjustment.
5. Press the gear button to increase the value (CFM) of the selected airflow until the target value (CFM) is reached. Press the water drop button to decrease the value (CFM) of the selected airflow until the target value (CFM) is reached. Once the target value (CFM) has been reached, the fans will adjust to meet the target value (CFM). Pause until the airflow values (CFM) have stabilized.

Airflow values (CFM) increase and decrease in increments of 5 CFM. CFM fluctuations of +/- 10 CFM from target is acceptable. A Balance Indicator icon is located to the right of the fan speed. The Balance Indicator icon will spin to indicate when there is more than 10 CFM difference between supply and exhaust airflows.

6. Once both the supply and exhaust airflows have stabilized to the target values, press the power button to save the settings. *No changes will be saved unless the power button is pressed before exiting the Auto Balance Screen. Saving the settings can be done at any time. Saving the settings after setting all 5 speeds is sufficient, however it is recommended to save after setting each speed, beginning with speed 5.*
7. Press the fan button to switch to the other 4 speeds and adjust using steps 4-6. *When switching fan speeds, the ERV will take approximately 5 seconds to identify the default airflow values (CFM) before displaying it. Note: All speeds do not have to be adjusted. After speed 5 is adjusted, speeds 1 to 4 will adjust proportionally to the selected speed 5 value, for both airflows. These default values can be overridden if desired by setting speeds 1 to speed 4 following steps 4-6.*
8. To exit auto balance mode and return to the main screen press the RESET button.

After approximately 3 seconds the screen will change back to the main screen. The screen will display “Auto Balance”. If this is not shown, restart from step 3.

Over time, if the unit is unable to remain balanced “Auto Balance” will no longer appear on the main screen and the unit will run its five speeds at factory default. The unit will continuously adjust to maintain selected airflow values.

* Man Balance is used for diagnostic purposes only.

Note

Should any unexpected behaviour occur on the Auto Balance Screen or on the HRV/ERV, disconnect the HRV/ERV from the outlet, wait approximately 30 seconds and start from step 1.

29 FAULT INDICATOR DISPLAY BOARD (FID)

DESCRIPTION OF OPERATION:

A FID enabled HRV or ERV is capable of displaying error codes for certain types of faults which impact operation of the system. These errors are displayed on the screen during normal operation (i.e. not while on any installer/service screens). Active error codes are displayed for approximately 1 second on a 5 second interval.

An error will be displayed in place of the relative humidity (RH) numbers. For example, error 1 would appear as the letters "Err" in place of the RH reading and "1" would appear in place of the RH setting.

In the case of multiple active errors only the highest priority error (smallest error number) is displayed.

Applicable unit: 267 MAX ERV-FID

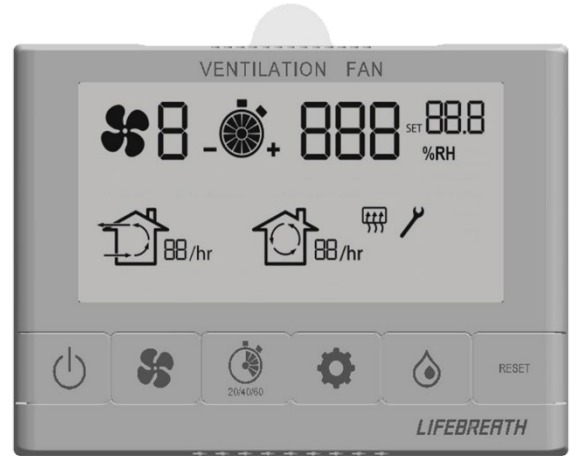

List of Error codes	
Err 1	Pressure Sensor Failure (either Supply or Exhaust)
Err 2	Temperature Sensor Failure
Err 3	Supply Airflow Too Low or Too High
Err 4	Exhaust Airflow Too Low or Too High
Err 8	Clean Filter (same as Wrench/Timer)
Watts	Displays Watts

DESCRIPTION OF ERRORS:

- Err 1: This error is activated if either the supply sensor or the exhaust sensor fails to respond or if the sensor is overloaded.
 Err 2: This error is activated if the thermistor connection is broken.
 Err 3: This error is activated if the HRV is unable to achieve the supply cfm air flow requested for the selected speed.
 The limit for cfm deviation from requested is: $\pm(15\text{cfm} + 10\% \text{ of setting})$.
 Err 4: This error is activated if the HRV is unable to achieve the exhaust cfm air flow requested for the selected speed.
 The limit for cfm deviation from requested is: $\pm(15\text{cfm} + 10\% \text{ of setting})$.
 Err 8: Filter change reminder activated.

Notes:

- Err 5, 6, 7 are spare and not currently used.
 Err 1, 3 & 4 will only be activated in Auto Balancing Mode.
 To prevent false alarms Err 1, 3 & 4 have a time delay built-in. These also tie into the fail-retry logic when in Auto Balancing.
 For example, the sequence of events for a pressure sensor failure would be:
- After selecting a speed or changing mode the system will disable speed/cfm alarms for 1-minute to allow the airflow to stabilize.
 - After 1 minute has passed the system will identify an issue with the sensor and start a 2-minute timer while it continues to attempt to communicate with the sensor.
 - After 2 minutes an alarm will be activated which is communicated to the DXPL03
 - The system will revert to Manual Mode for 3 minutes. During this time the alarm is still active.
 - After 3 minutes the alarms are cleared and the system attempts to restore Auto Balancing.
 - System goes back to step (a)

The result of this sequence is that the alarm will flash on the DXPL03 display for 3 minutes then get cleared for 3 minutes. This repeats until the issue is resolved or the system is switched to Man Balance.

Power Monitor Consumption Description

Power monitor consumption mode is activated on 99-DXPL03 by pressing GEAR icon followed by POWER icon and holding both for 5 seconds on 99-DXPL03 after unit has completed self-test.
 Power is displayed in watts in place of the relative humidity (RH) numbers. Power monitor consumption mode is cancelled by cycling power. This mode will time out in 5 minutes after it is first activated.

30 TROUBLESHOOTING

Refer to the following table for troubleshooting the ERV unit.

Table 17.1 – Troubleshooting Procedures

SYMPTOM	CAUSE	SOLUTION
Poor airflows	<ul style="list-style-type: none"> • 1/4 in (6mm) mesh on outside hood is plugged • Filters plugged • Core obstructed • House grilles closed or blocked • Dampers are closed if installed • Poor power supply at site • Ductwork is restricting ERV • Improper speed control setting • ERV airflow improperly balanced 	<ul style="list-style-type: none"> • Clean exterior hoods or vents • Remove and clean filter • Remove and clean core • Check and open grilles • Open and adjust dampers • Have electrician check supply voltage • Check duct installation • Increase the speed of the ERV • Have contractor balance ERV
Supply air feels cold	<ul style="list-style-type: none"> • Poor location of supply grilles, the airflow may irritate the occupant • Outdoor temperature extremely cold 	<ul style="list-style-type: none"> • Locate the grilles high on the walls or under the baseboards, install ceiling mounted diffuse or grilles so as not to directly spill the supply air on the occupant (i.e. over a sofa) • Turn down the ERV supply speed. A small duct heater (1 kW) could be used to temper the supply air • Placement of furniture or closed doors is restricting the movement of air in the home • If supply air is ducted into furnace return, the furnace fan may need to run continuously to distribute ventilation air comfortably
Dehumidistat is not operating	<ul style="list-style-type: none"> • Outdoor temperature is above 15°C (59°F) • Improper low voltage connection • External low voltage is shortened out by a staple or nail • Check dehumidistat setting it may be on OFF 	<ul style="list-style-type: none"> • Dehumidistat is functioning normally (see Auto Dehumidistat Disable in this manual) • Check that the correct terminals have been used • Check external wiring for a short • Set the dehumidistat at the desired setting

30 TROUBLESHOOTING

Refer to the following table for troubleshooting the ERV unit.

Table 17.1 – Troubleshooting Procedures (cont.)

SYMPTOM	CAUSE	SOLUTION
Humidity levels are too high condensation is appearing on the windows	<ul style="list-style-type: none"> • Dehumidistat is set too high • ERV is not sized to handle a hot tub, indoor pool etc. • Lifestyle of the occupants Moisture coming into the home from an unvented or unheated crawl space • Moisture is remaining in the washroom and kitchen areas • Condensation seems to form in the spring and fall • ERV is set at too low a speed 	<ul style="list-style-type: none"> • Set dehumidistat lower • Cover pools, hot tubs when they are not in use • Avoid hanging clothes to dry, storing wood and venting clothes dryer inside. Firewood may have to be moved outside • Vent crawl space and place a vapor barrier on the floor of the crawl space • Ducts from the washroom should be sized to remove moist air as effectively as possible, use of a bathroom fan for short periods will remove additional moisture • On humid days, as the seasons change, some condensation may appear, but the homes air quality will remain high with some ERV use Increase speed of the ERV
Humidity levels are too low	<ul style="list-style-type: none"> • Dehumidistat control set too low • Blower speed of ERV is too high • Lifestyle of occupants • ERV airflows may be improperly balanced 	<ul style="list-style-type: none"> • Set dehumidistat higher • Decrease ERV blower speed • Humidity may have to be added through the use of humidifiers • Have contractor balance ERV airflows
ERV and/or ducts frosting up	<ul style="list-style-type: none"> • ERV airflows are improperly balanced • Malfunction of the ERV defrost system 	<div data-bbox="951 1140 1498 1272" style="border: 1px solid black; padding: 5px;"> <p>Note</p> <ul style="list-style-type: none"> • Minimal frost build-up is expected on cores before unit initiates defrost cycle functions </div> <ul style="list-style-type: none"> • Have HVAC contractor balance the ERV • Ensure damper defrost is operating during self-test
Condensation or ice buildup in insulated duct to the outside	<ul style="list-style-type: none"> • Incomplete vapor barrier around insulated duct • A hole or tear in outer duct covering 	<ul style="list-style-type: none"> • Tape and seal all joints • Tape any holes or tears made in the outer duct cover, ensure that the vapor barrier is completely sealed.
Excessive Vibration	<ul style="list-style-type: none"> • Dirt on fan wheels 	<ul style="list-style-type: none"> • Have contractor service ERV