

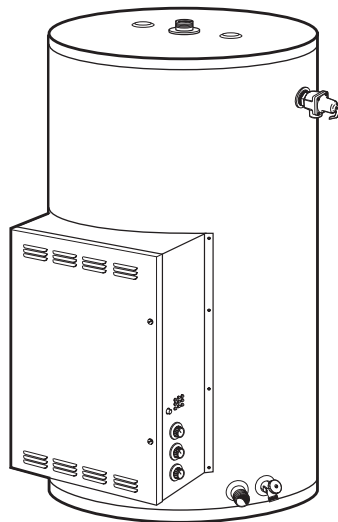

# Commercial Electric Water Heaters CONVERSION KIT INSTRUCTIONS

FOR INSTALLATION BY QUALIFIED SERVICE PERSONNEL ONLY



Heavy Duty Series E(S)50, E(S)85,  
and E(S)120 Configuration

**▲ CAUTION: TEXT PRINTED OR OUTLINED IN RED  
CONTAINS INFORMATION RELATIVE TO YOUR SAFETY.  
PLEASE READ THOROUGHLY BEFORE ATTEMPTING ANY  
CONVERSION.**



**LISTED**  
COMMERCIAL STORAGE  
TANK WATER HEATER  
1860

# FOREWORD

---

The purpose of this manual is to explain how to change the voltage and wattage of a Rheem/Ruud commercial electric water heater when changing the elements. This manual is not intended to explain the reconstruction of commercial electric water heaters in the field.

The addition of heating elements or subtraction of heating elements in the field is not approved by Underwriters Laboratories, Inc., and therefore, is not allowed and should not be attempted.

Please note the limitation that “both the heater required and the heater to be converted must be found in this manual. Before attempting any conversion read the detailed instructions.

## **▲ SAFETY**

Be sure to disconnect appliance from electrical supply before working on or near the electrical system of the heater. Never touch electrical components with wet hands or when standing in water.

## **REQUIRED ABILITY**

CONVERSION OF ANY WATER HEATER LISTED IN THIS MANUAL REQUIRES ABILITY EQUIVALENT TO THAT OF A LICENSED ELECTRICAL TRADESMAN.

## **NOTICE!!**

You **MUST** use Factory Authorized Replacement Parts when converting electric water heaters per this Procedure.

# TABLE OF CONTENTS

Conversion Materials	3
Conversion Guidelines	4
Maximum Voltage and Wattage Input Charts	5-6
Conversion Procedure	7
New Rating Label Instructions	8
Wiring Diagrams	10-16

## CONVERSION MATERIALS

1. Element Plug Remover: or 1-1/2" deep well socket and ratchet.
2. Screwdrivers: Two required. One #2 Phillips and one slotted screwdriver.
3. Conversion kit: Includes conversion instructions. Replacement electrical elements, element gaskets, conversion kit label, and caution label.

# CONVERSION GUIDELINES

**Be sure to read and understand the following guidelines before starting any conversion.**

- 1.) Conversions are designed to be made only where the number of factory heating elements are replaced by the same number of conversion heating elements.
- 2.) The Element Usage Table below indicates the configurations possible for these series of water heaters. Refer to the Commercial Electric Conversion Guide on page 3 through 5 for electrical specifications applicable to specific configurations.

## Heavy Duty Series E(S)50, E(S)85 & E(S)120 Configurations

Zone	Input KW	No. of Elements	Element Wattage	Available Voltages
1	6	3	2000	208, 240, 277, 480
	9		3000	208, 240, 277, 480
	12		4000	208, 240, 277, 480
	15		5000	208, 240, 277, 480
	18		6000	240, 277, 480
2	18	6	3000	208, 240, 277, 480
	24		4000	208, 240, 277, 480
	27		4500	208, 240, 277, 480
	30		5000	208, 240, 277, 480
	36		6000	240, 277, 480
3	36	9	4000	208, 240, 277, 480
	45		5000	208, 240, 277, 480
	54		6000	208, 240, 277, 480

**NOTICE: When converting a ZONE 2 heater from 18kW, 24kW and 27kW to 30kW, the T&P relief valve may also need to be changed. Ensure the T&P relief valve is rated for 200,000 BTU when making these type of conversions.**

**Notes:**

1. In Zone 1 - Use Element Locations 1 - 3.  
In Zone 2 - Use Element Locations 1 - 6.  
In Zone 3 - Use Element Locations 1 - 9.
2. **CONVERT HEATERS ONLY WITHIN THE SAME ZONE!!** Units from different zones may have different components, or component ratings.

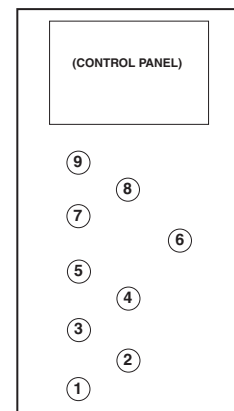

**ELEMENT LOCATIONS**

# AVAILABLE KIT FOR THE E(S)50, E(S)85, & E(S)120

ZONE	AVAILABLE VOLTAGES	INPUT KW	NUMBER OF ELEMENTS	ELEMENT WATTAGE	KIT NUMBER
1	208	6	3	2000	SP20511
		9		3000	SP20512
		12		4000	SP20513
		15		5000	SP20514
2	208	18	6	3000	SP20516
		24		4000	SP20517
		27		4500	SP20518
		30		5000	SP20519
3	208	36	9	4000	SP20521
		45		5000	SP20522
		54		6000	SP20523

ZONE	AVAILABLE VOLTAGES	INPUT KW	NUMBER OF ELEMENTS	ELEMENT WATTAGE	KIT NUMBER
1	240	6	3	2000	SP20524
		9		3000	SP20525
		12		4000	SP20526
		15		5000	SP20527
		18		6000	SP20528
2	240	18	6	3000	SP20529
		24		4000	SP20530
		27		4500	SP20531
		30		5000	SP20532
		36		6000	SP20533
3	240	36	9	4000	SP20534
		45		5000	SP20535
		54		6000	SP20669

# AVAILABLE KIT FOR THE E(S)50, E(S)85, & E(S)120 CONT.

**▲ CAUTION: THE 277 VOLTAGES CAN ONLY BE CONVERTED USING SINGLE PHASE MODELS.**

ZONE	AVAILABLE VOLTAGES	INPUT KW	NUMBER OF ELEMENTS	ELEMENT WATTAGE	KIT NUMBER
1	277	6	3	2000	SP20536
		9		3000	SP20537
		12		4000	SP20538
		15		5000	SP20539
		18		6000	SP20540
2	277	18	6	3000	SP20541
		24		4000	SP20542
		27		4500	SP20543
		30		5000	SP20544
		36		6000	SP20545
3	277	36	9	4000	SP20546
		45		5000	SP20547
		54		6000	SP20548

ZONE	AVAILABLE VOLTAGES	INPUT KW	NUMBER OF ELEMENTS	ELEMENT WATTAGE	KIT NUMBER
1	480	6	3	2000	SP20549
		9		3000	SP20550
		12		4000	SP20551
		15		5000	SP20552
		18		6000	SP20553
2	480	18	6	3000	SP20554
		24		4000	SP20555
		27		4500	SP20556
		30		5000	SP20557
		36		6000	SP20558
3	480	36	9	4000	SP20559
		45		5000	SP20560
		54		6000	SP20561

# CONVERSION PROCEDURE

1. Follow the matrix of the Conversion Guide on page 5 and 6 to determine the zone of your water heater. Refer to the rating label for the input and voltage. You can convert between different wattages i.e. 2000W to 4000 **WITHIN THE SAME ZONE**. However, you cannot convert outside of the zone of your water heater.
2. Confirm the correct kit was received.
3. Unpack the heater and open the access panel to the element cavity.
4. Remove the thermostat cover and insulation if applicable. **DO NOT REMOVE THE ELEMENT WIRING YET!**
5. Do **ONE** element at a time, perform the following steps.
6. For one element only, remove the black and red element leads.
7. With an element wrench, unscrew the old element from the heater tank.

**▲ CAUTION: The following procedure (Step 8) MUST be performed before proceeding further. Failure to do so could result in equipment damage or bodily injury.**

8. To the new element, add a **NEW** gasket (ME models element have preinstalled gaskets). Assemble the new element into the tank using an element wrench. Snug the element up firmly.
9. Wire the element by attaching the water heater red and black leads to the elements.
10. Finish converting the heater, one element at a time, following steps 5 through 9.

**▲ CAUTION: CHECK ALL WATER AND ELECTRICAL CONNECTIONS FOR TIGHTNESS.**

11. **Recheck all terminals for tightness, proper wiring per schematic, and neatness of wiring. Heater should be no less than factory constructed quality and appearance.**
12. If a voltage change was made on the heater, move the **RED** transformer lead to the proper voltage terminal.
13. If a phase change is required, refer to the wiring diagram affixed to the control enclosure door for exact red / black wire arrangement at the field wiring block. (Wiring diagrams may also be found in the appendix of this procedure or in the Use and Care Manual.)
14. Replace thermostat cover and insulation to element cavity, if applicable, and close control enclosure.
15. Place new rating label overlay over existing rating label. Refer to "New Rating Label Instructions" (page 8) for details.
16. Re-package the water heater. Mark new wattage, voltage and phase information on the carton tag.

# NEW RATING LABEL INSTRUCTIONS

RATING LABEL MODIFICATION OF ELEMENTS FOR ELECTRIC WATER HEATERS.

The following is a sample of the standard rating label supplied on the front of the ELD.



## COMMERCIAL

---

**COMMERCIAL STORAGE TANK OR BOOSTER WATER HEATER**

MAY BE INSTALLED ON COMBUSTIBLE FLOORING. MINIMUM CLEARANCE TO ADJACENT SURFACES: 0 IN. JACKET; 18 IN. ACCESS DOOR.

**SERIAL NO.** R1094E00001    **MFG. DATE:** 10/2004

**MODEL NO.** ES120-36-G

**CAPACITY** 120 U.S. GALLONS    **150 PSI MAX WORKING PRESSURE**

**COPPER SUPPLY CONDUCTOR SUITABLE FOR 75°C**

208 VAC 50/60 HZ 36KW 1 PH 174 AMPS    **MIN CONDUCTOR #4/0 AWG**

208 VAC 50/60 HZ 36KW 3 PH 100 AMPS    **MIN CONDUCTOR #1 AWG**

COMPLIES WITH  
ASHRAE/IES 90.1b-1989  
1992 REQUIREMENTS



**LISTED**  
Commercial Storage  
Tank/Booster Water  
Heater  
**18GO**

RHEEM SALES COMPANY, INC.  
WATER HEATER DIVISION

MONTGOMERY, ALABAMA, USA

## CONVERTED RATING LABEL

THE VOLTS, WATTS, AND PHASE INFORMATION OF THE RATING LABEL MUST BE MODIFIED BY COVERING THEM WITH CONVERSION LABEL PROVIDED IN THE CONVERSION KIT.

BE SURE THE NEW RATINGS ON THE LABEL MATCH THE CONVERSION YOU HAVE JUST COMPLETED.

480 VAC 50/60 HZ 54KW 1 PH 113 AMPS    **MIN CONDUCTOR #1/0 AWG**

480 VAC 50/60 HZ 54KW 3 PH 65 AMPS    **MIN CONDUCTOR #4 AWG**

PEEL OFF THE BACK OF THE LABEL AND PASTE OVER THE ORIGINAL AS SHOWN ON THE REVISED RATING LABEL BELOW.



## COMMERCIAL

---

**COMMERCIAL STORAGE TANK OR BOOSTER WATER HEATER**

MAY BE INSTALLED ON COMBUSTIBLE FLOORING. MINIMUM CLEARANCE TO ADJACENT SURFACES: 0 IN. JACKET; 18 IN. ACCESS DOOR.

**SERIAL NO.** R1094E00001    **MFG. DATE:** 10/2004

**MODEL NO.** ES120-36-G

**CAPACITY** 120 U.S. GALLONS    **150 PSI MAX WORKING PRESSURE**

**COPPER SUPPLY CONDUCTOR SUITABLE FOR 75°C**

480 VAC 50/60 HZ 54KW 1 PH 113 AMPS    **MIN CONDUCTOR #1/0 AWG**

480 VAC 50/60 HZ 54KW 3 PH 65 AMPS    **MIN CONDUCTOR #4 AWG**

COMPLIES WITH  
ASHRAE/IES 90.1b-1989  
1992 REQUIREMENTS



**LISTED**  
Commercial Storage  
Tank/Booster Water  
Heater  
**18GO**

RHEEM SALES COMPANY, INC.  
WATER HEATER DIVISION

MONTGOMERY, ALABAMA, USA

## ADDITIONAL LABELING INSTRUCTIONS

Verify that this number matches the conversion kit that was ordered.

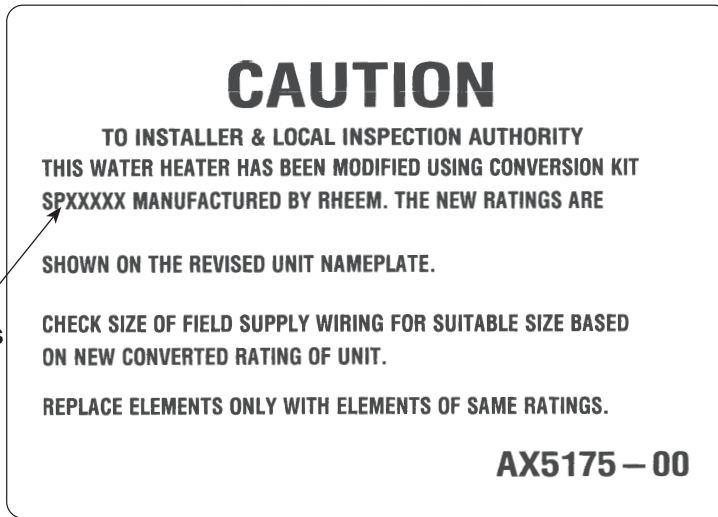

Peel off the back of the caution label and attach to the upper right hand corner of the control panel door.

Close and tape cardboard flap on front of carton.

**NOTICE:** NEVER OPERATE THE HEATER WITHOUT FILLING IT WITH WATER PER THE FILLING INSTRUCTIONS. FAILURE TO DO SO WILL DAMAGE INTERNAL PARTS.

Using a black magic marker, cross out the heater identification on the carton as appropriate. In bold letters, write the new electrical specifications on the carton, which matches those on the revised rating label.

**NOTICE:** FOR CONVERTED WATER HEATERS, THE MODEL NUMBER WILL NOT DICTATE THE CONFIGURATION OF THE UNIT. PLEASE REFER TO THE UPDATED RATING LABEL OVERLAY FOR THE CONFIGURATION OF THE CONVERTED WATER HEATER. PLEASE INCLUDE THE UPDATED RATING AND THE SPXXXXX CONVERSION KIT NUMBER LISTED ON THE CAUTION LABEL FOR ANY COMMUNICATION REGARDING THIS WATER HEATER.

# Wiring Diagram: Surface Mounted Thermostat Models

## -G Models 3 & 6 Element Models Only

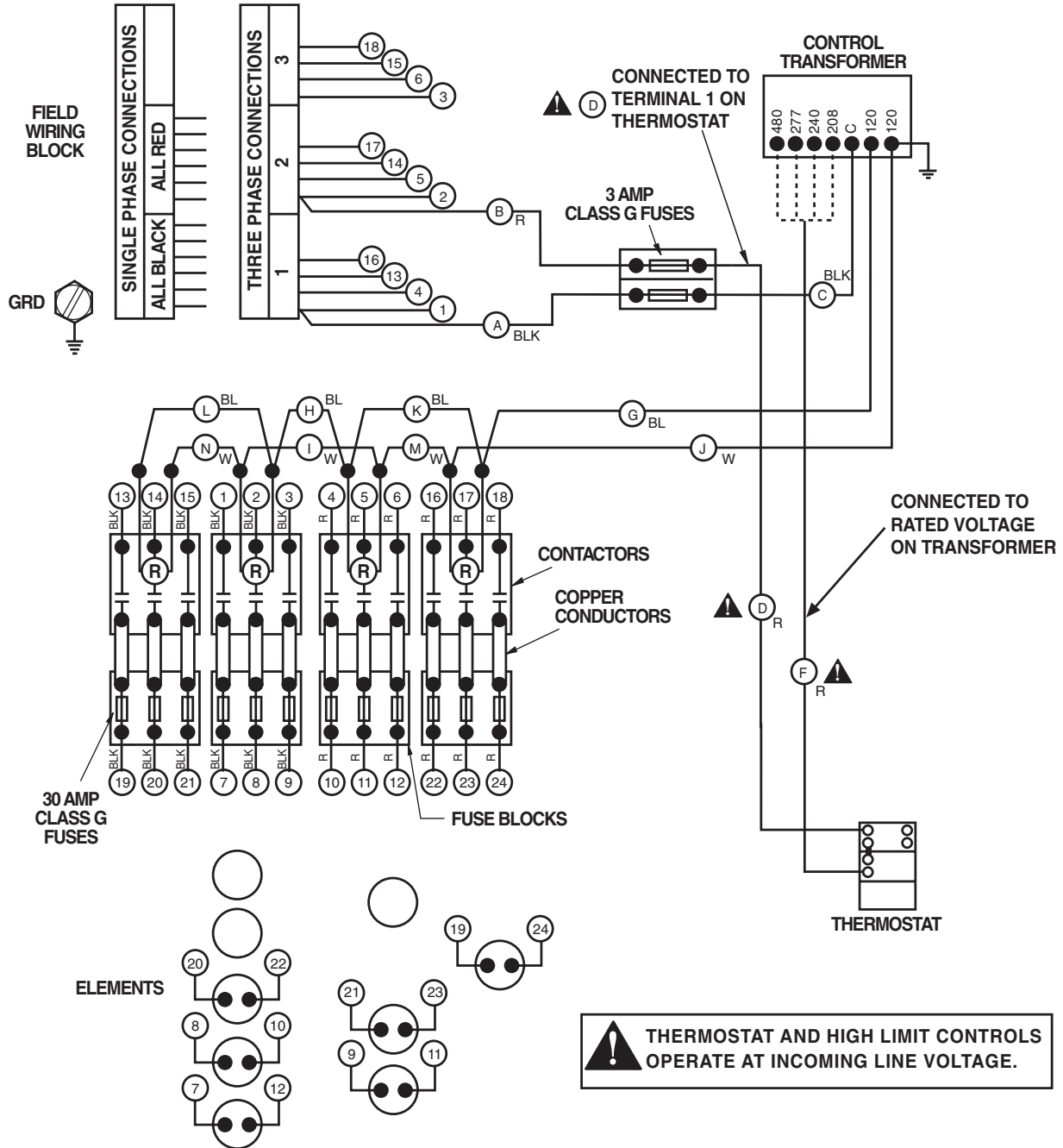

**⚠ THERMOSTAT AND HIGH LIMIT CONTROLS OPERATE AT INCOMING LINE VOLTAGE.**

No. of Elements	Follow Wire Routes
3	1 thru 12, A thru J
6	1 thru 24, A thru N

**NOTE:**  
To insure proper thermostat response, be sure to replace insulation pad tightly over elements after servicing.

**NOTE:**  
THIS WATER HEATER MAY BE SUPPLIED BY A BRANCH CIRCUIT HAVING OVER 300 VOLTS BETWEEN CONDUCTORS, PROVIDED THE SYSTEM HAS A GROUND NEUTRAL AND NO CONDUCTOR IS OVER 300 VOLTS TO GROUND.

# Wiring Diagram: Surface Mounted Thermostat Models -G Models 9 Element Configuration Only

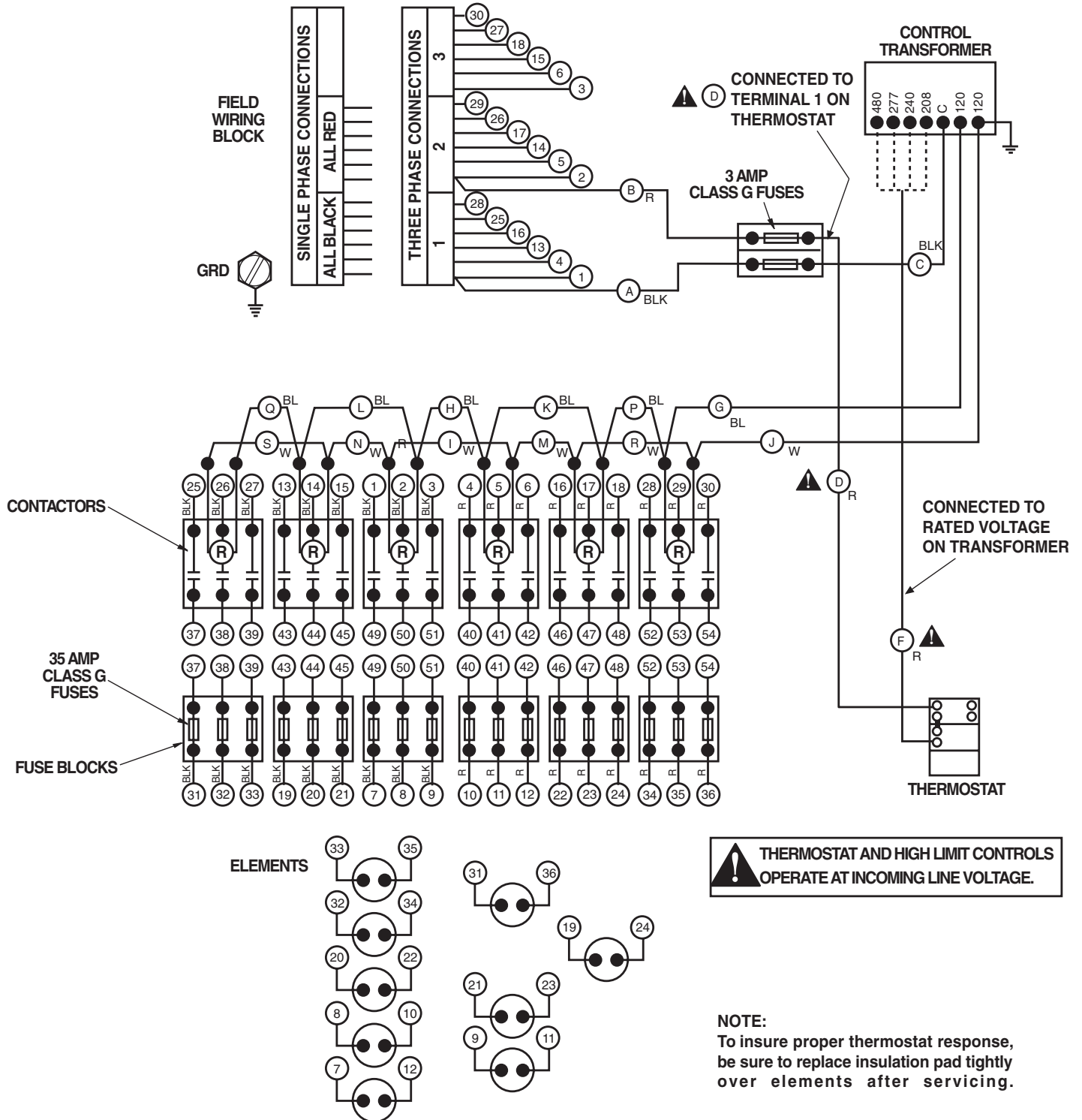

**NOTE:**  
THIS WATER HEATER MAY BE SUPPLIED BY A BRANCH CIRCUIT HAVING OVER 300 VOLTS BETWEEN CONDUCTORS, PROVIDED THE SYSTEM HAS A GROUND NEUTRAL AND NO CONDUCTOR IS OVER 300 VOLTS TO GROUND.

# Wiring Diagram: Immersion Thermostat Models

-G Models

3 & 6 Element Configurations Only

Up to 30 Amp Fuses

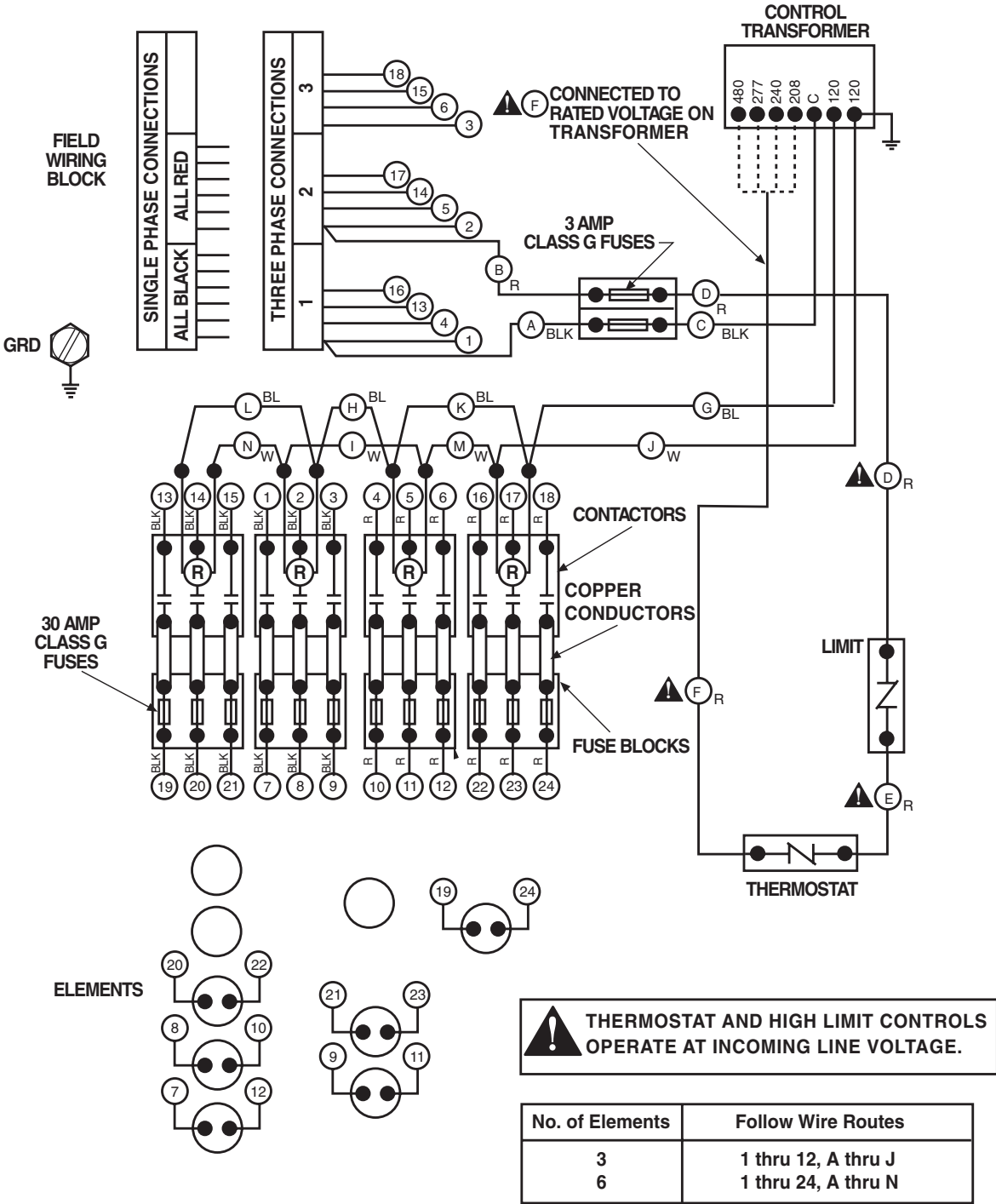

**NOTE:**  
THIS WATER HEATER MAY BE SUPPLIED BY A BRANCH CIRCUIT HAVING OVER 300 VOLTS BETWEEN CONDUCTORS, PROVIDED THE SYSTEM HAS A GROUND NEUTRAL AND NO CONDUCTOR IS OVER 300 VOLTS TO GROUND.

# Wiring Diagram: Immersion Thermostat Models

-G Models

3 & 6 Element Configurations Only

35 Amp Fuse

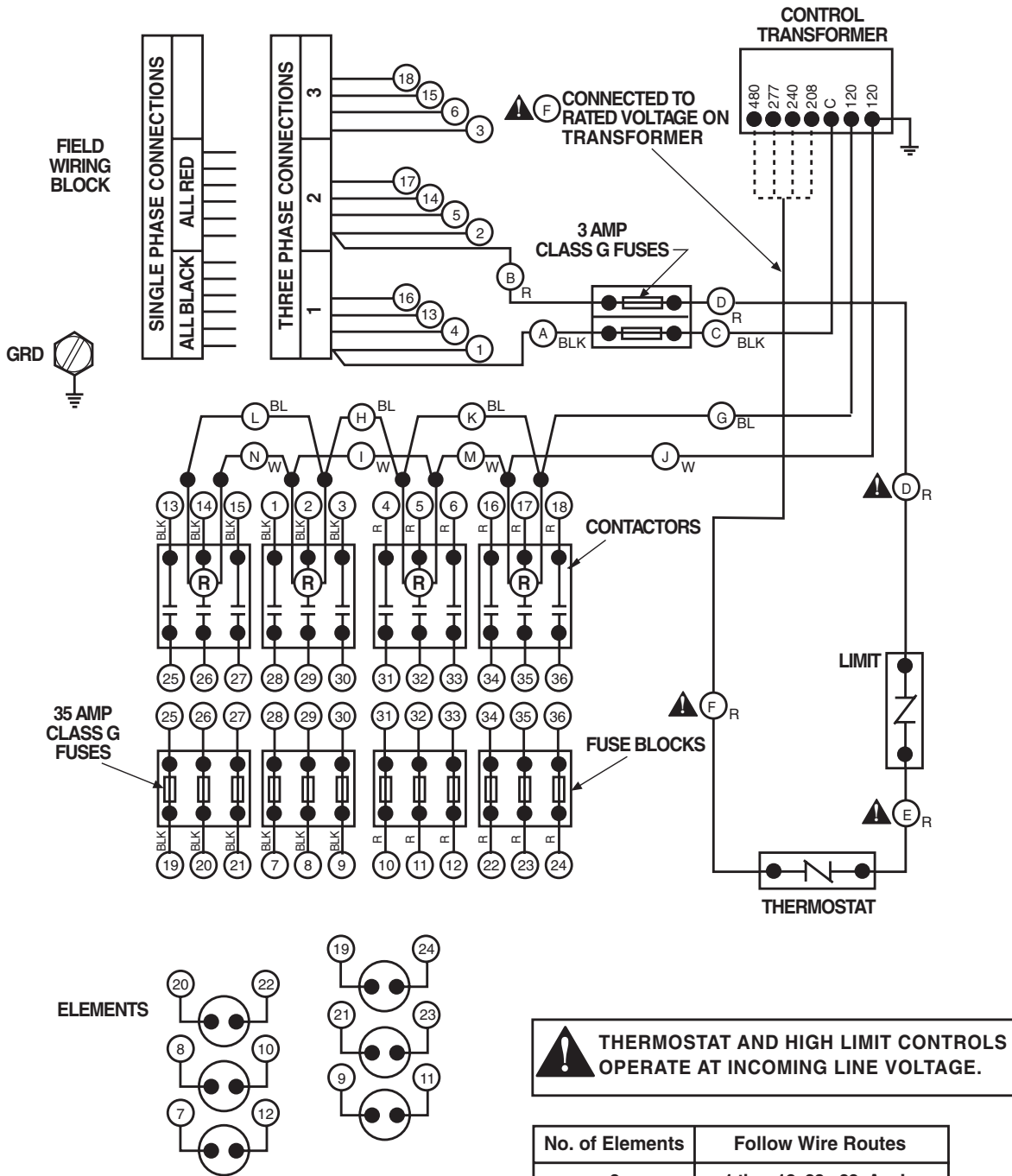

**! THERMOSTAT AND HIGH LIMIT CONTROLS OPERATE AT INCOMING LINE VOLTAGE.**

No. of Elements	Follow Wire Routes
3	1 thru 12, 28 - 33, A - J
6	1 thru 36, A - N

**NOTE:**  
THIS WATER HEATER MAY BE SUPPLIED BY A BRANCH CIRCUIT HAVING OVER 300 VOLTS BETWEEN CONDUCTORS, PROVIDED THE SYSTEM HAS A GROUND NEUTRAL AND NO CONDUCTOR IS OVER 300 VOLTS TO GROUND.

# Wiring Diagram: Immersion Thermostat Models -G Models 9 Element Configuration Only

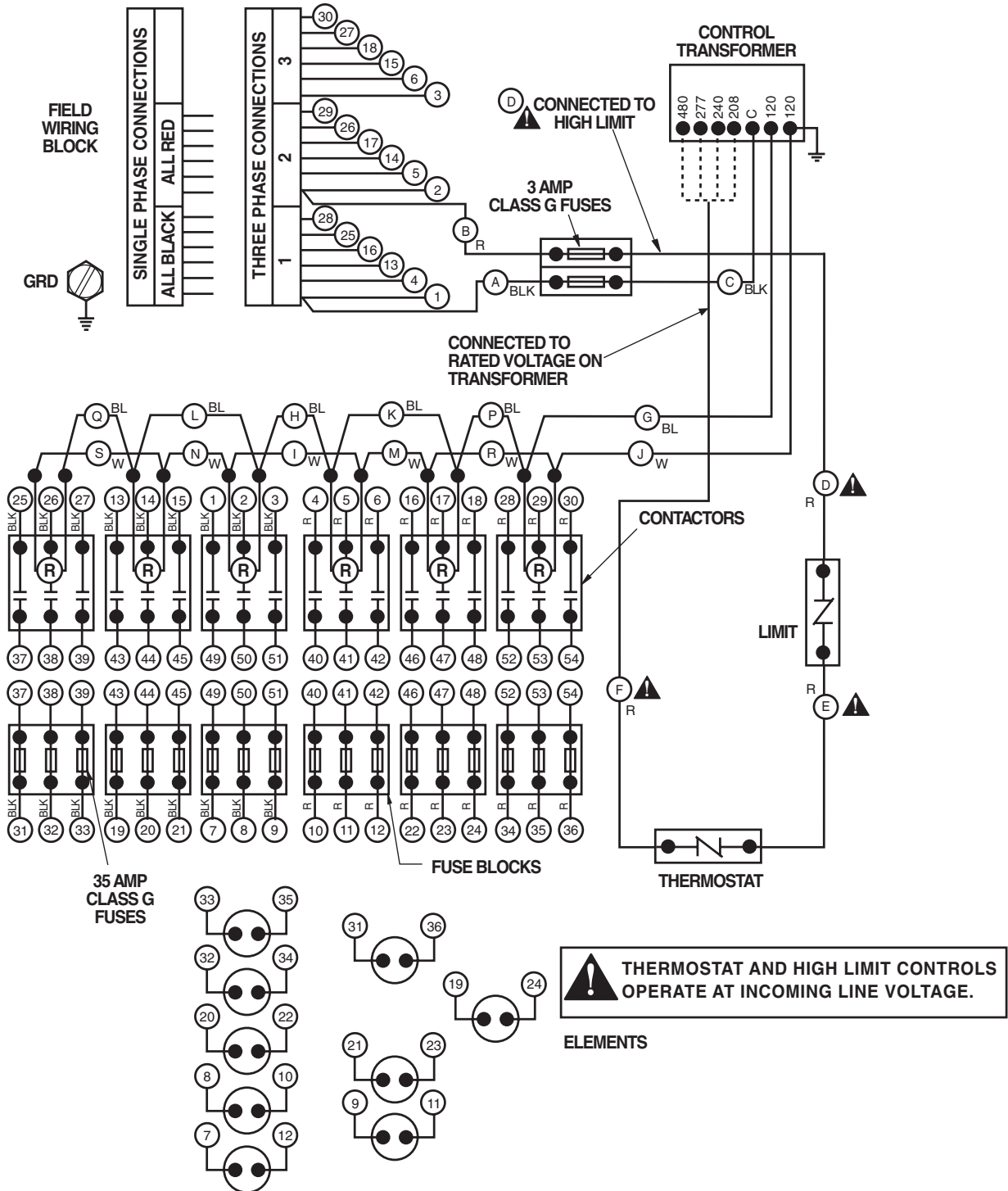

# Wiring Diagram: Immersion Thermostat Models with Staging 2 Stage -GS Models

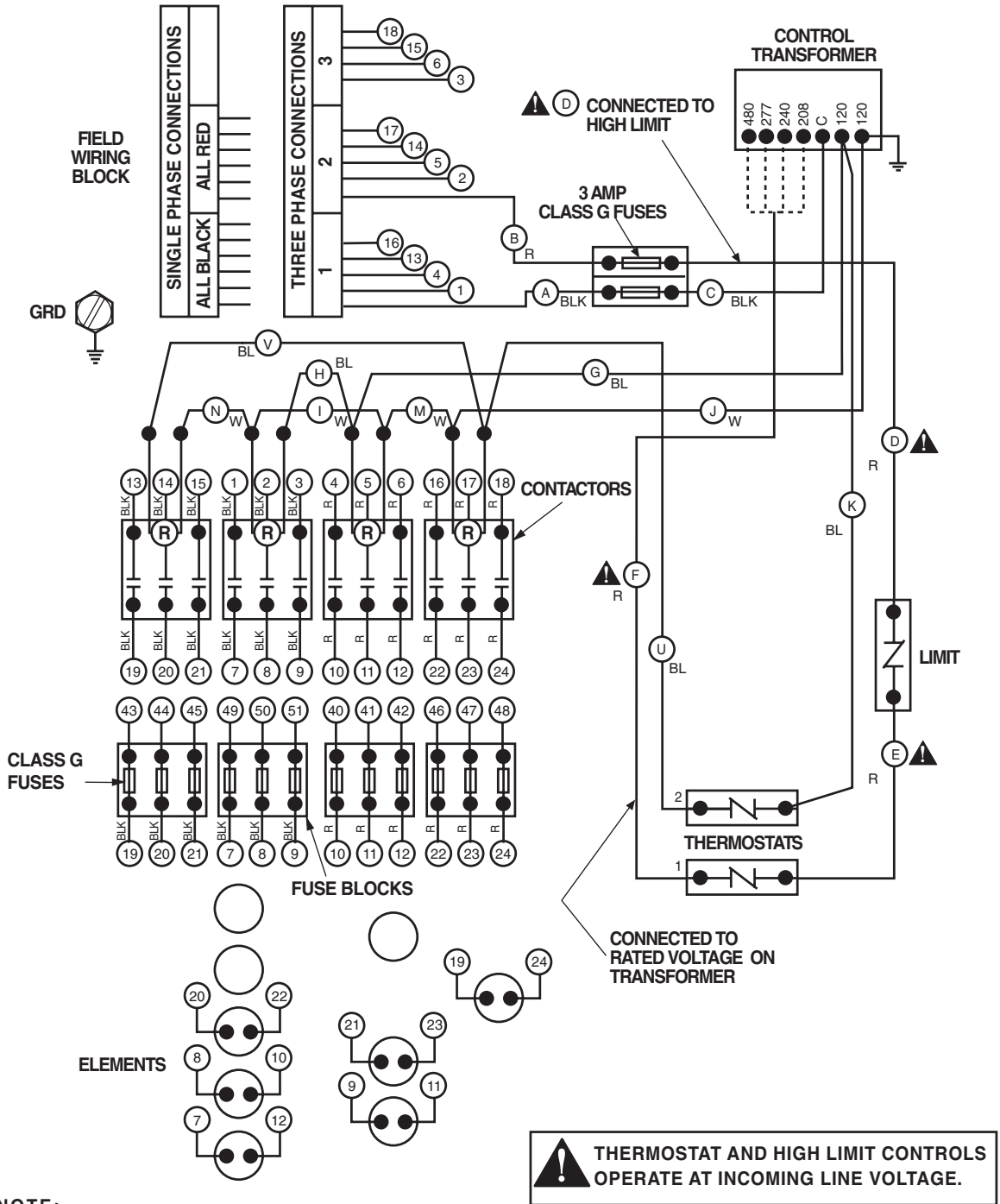

**NOTE:**  
THIS WATER HEATER MAY BE SUPPLIED BY A BRANCH CIRCUIT HAVING OVER 300 VOLTS BETWEEN CONDUCTORS, PROVIDED THE SYSTEM HAS A GROUND NEUTRAL AND NO CONDUCTOR IS OVER 300 VOLTS TO GROUND.

# Wiring Diagram: Immersion Thermostat Models with Staging

## 3 Stage -GS Models

