

**▲WARNING:** This water heater is not suitable for use in manufactured (mobile) homes!

## Use & Care Manual With Installation Instructions for the Installer

# Residential Gas - FVIR Certified PowerDirectVent Water Heaters

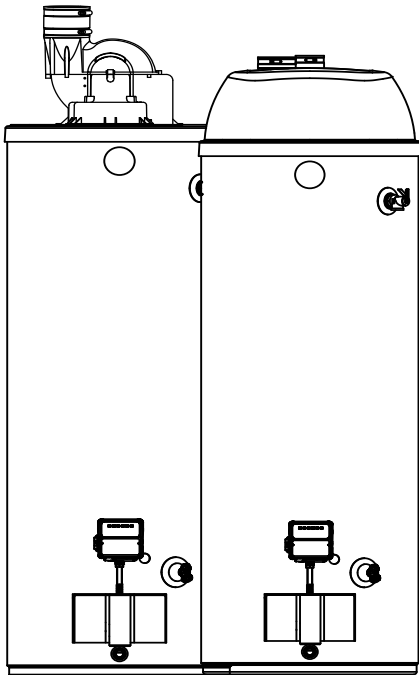

The purpose of this manual is twofold: one, to provide the installer with the basic directions and recommendations for the proper installation and adjustment of the water heater; and two, for the owner-operator, to explain the features, operation, safety precautions, maintenance and troubleshooting of the water heater. This manual also includes a parts list.

It is very important that all persons who are expected to install, operate or adjust this water heater read the instructions carefully so they may understand how to perform these operations. If you do not understand these instructions or any terms within it, seek professional assistance.

Any questions regarding the operation, maintenance, service or warranty of this water heater should be directed to the seller from whom it was purchased. If additional information is required, refer to the section on "If you need service."

**Do not destroy this manual. Please read carefully and keep in a safe place for future reference.**



**Recognize this symbol as an indication of Important Safety Information!**



**California Proposition 65 Warning:** This product contains chemicals known to the State of California to cause cancer, birth defects or other reproductive harm.



**WARNING:** If the information in these instructions is not followed exactly, a fire or explosion may result causing property damage, personal injury or death.

### ▲ FOR YOUR SAFETY!

— Do not store or use gasoline or other flammable vapors or liquids or other combustible materials in the vicinity of this or any other appliance. To do so may result in an explosion or fire.

### — WHAT TO DO IF YOU SMELL GAS

- Do not try to light any appliance.
- Do not touch any electrical switch; do not use any phone in your building.
- Immediately call your gas supplier from a neighbor's phone. Follow the gas supplier's instructions.

- If you cannot reach your gas supplier, call the fire department.
- Do not return to your home until authorized by the gas supplier or fire department.
- Improper installation, adjustment, alteration, service or maintenance can cause property damage, personal injury, or death. Refer to this manual. Installation and service must be performed by a qualified installer, service agency or the gas supplier.



## Safety Information

Safety Precautions . . . . . 3-6

LP Gas Models . . . . . 5

## Installing the Water Heater

Location . . . . . 7

Water Supply Connections . . 8

Gas Supply . . . . . 10

Vent and Combustion

Air-Inlet . . . . . 11-27

Condensate Management . . .28

Wiring Diagram . . . . . 29

Pipe Insulation . . . . . 30

Heat Traps . . . . . 31

Installation Checklist . . . . . 32

Potable/Space Heating . . . . 33

## Operating Instructions

Lighting Instructions . . . . . 34

Water Temperature . . . . . 35-37

## Care and Cleaning

Draining . . . . . 38

Maintenance . . . . . 38

Vent System Inspection . . . . 39

Burner Inspection . . . . . 39

Extended Shut-Down . . . . . 39

## Troubleshooting Tips

Before You Call

For Service . . . . . 40-41

LED Codes . . . . . 42

## Customer Service

Parts List . . . . . 43

If You Need Service . . . . . 44



## FOR YOUR RECORDS

Write the model and serial numbers here:

# \_\_\_\_\_

# \_\_\_\_\_

You can find them on a label on the appliance.

**Staple sales slip or cancelled check here.**

Proof of the original purchase date is needed to obtain service under the warranty.



## READ THIS MANUAL

Inside you will find many helpful hints on how to use and maintain your water heater properly. A little preventive care on your part can save you time and money over the life of your water heater.

You'll find many answers to common problems in the Troubleshooting Guide. If you review the chart of Troubleshooting Tips first, you may not need to call for service.



## READ THE SAFETY INFORMATION

**Your safety and the safety of others are very important. There are many important safety messages in this manual and on your appliance. Always read and obey all safety messages.**



**This is the safety alert symbol. Recognize this symbol as an indication of Important Safety Information! This symbol alerts you to potential hazards that can kill or hurt you and others.**

All safety messages will follow the safety alert symbol and either the word "DANGER", "WARNING", "CAUTION" or "NOTICE".

These words mean:

**▲ DANGER**

**An imminently hazardous situation that will result in death or serious injury.**

**▲ WARNING**

**A potentially hazardous situation that could result in death or serious injury and/or damage to property.**

**▲ CAUTION**

**A potentially hazardous situation that may result in minor moderate injury.**

**NOTICE:**

**Attention is called to observe a specified procedure or maintain a specific condition.**

# IMPORTANT SAFETY INFORMATION

## READ ALL INSTRUCTIONS BEFORE USING

Be sure to read and understand the entire Use and Care Manual before attempting to install or operate this water heater. It may save you time and money. Pay particular attention to the Safety Instructions. Failure to follow these warnings could result in serious bodily injury or death. Should you have problems understanding the instructions in this manual, or have any questions, STOP, and get help from a qualified service technician, or the local gas utility.

**NOTICE:** This water heater is equipped with a flammable vapor sensor that will automatically shut down the water heater in the presence of gasoline vapors and some other flammable vapors. If the flammable vapor sensor shuts down the water heater, contact a qualified service technician. Clear any hazardous materials and ventilate the area around the water heater. **DO NOT** turn off the appliance or adjust the ON/OFF switch in any way. **DO NOT** tamper with the flammable vapor sensor. **DO NOT** submerge the flammable vapor sensor in water. **DO NOT** allow the flammable vapor sensor to come into contact with any substances such as bleach or cleaners. See the “Gas Valve LED Code” Section of this manual for a list of diagnostic codes.

### **DANGER!**

#### PROPERLY VENT THE WATER HEATER



Failure to properly vent the water heater as outlined in the Vent and Combustion Air-Inlet Section of the Installation Instructions in this manual can result in unsafe operation of the water heater. To avoid the risk of fire, explosion, or asphyxiation from carbon monoxide, never operate this water heater unless both the vent and combustion air-inlet systems are properly installed. Be sure to inspect both the vent and combustion air-inlet for proper installation at initial start-up; and at least periodically thereafter. Refer to the Care and Cleaning section of this manual for more information regarding vent and combustion air-inlet system inspection.

### **WARNING!**

Gasoline, as well as other flammable materials and liquids (which include but are not limited to adhesives, solvents, paint thinners etc.), and the vapors they produce are extremely dangerous. **DO NOT** handle, use or store gasoline or other flammable or combustible materials anywhere near or in the vicinity of a water heater or any other appliance. Be sure to read and follow warning label pictured below and other labels on the water heater, as well as the warnings printed in this manual. Failure to do so can result in property damage, bodily injury or death.

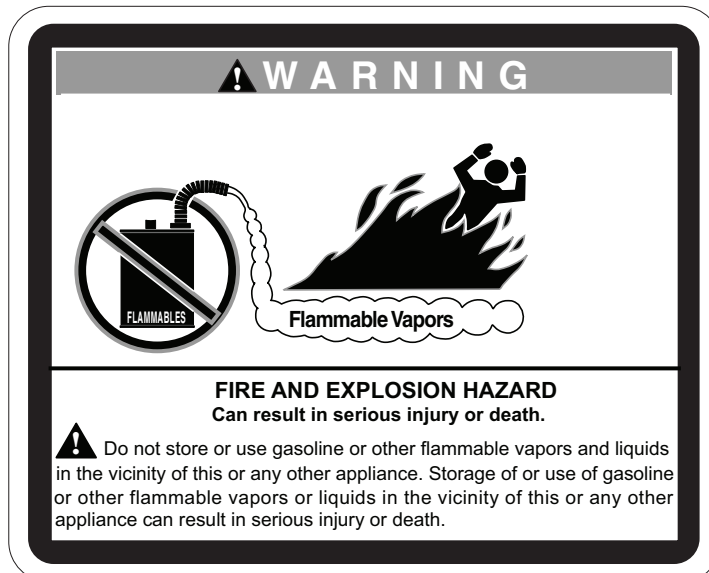

# IMPORTANT SAFETY INFORMATION. READ ALL INSTRUCTIONS BEFORE USING



## ⚠️ DANGER!

### WATER TEMPERATURE SETTING

Safety and energy conservation are factors to be considered when selecting the water temperature setting of a water heater's combination gas control. Water temperatures above 125°F (52°C) can cause severe burns or death from scalding. Be sure to read and follow the warnings outlined on the label pictured below. This label is also located on the water heater.

⚠️ **DANGER**

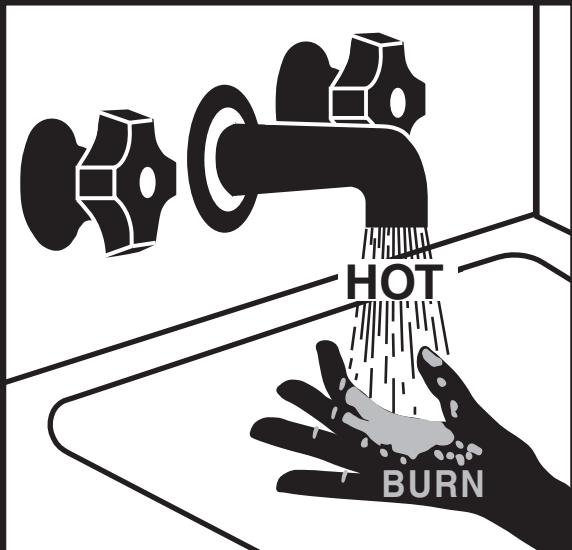

**Water temperature over 125° F can cause severe burns instantly or death from scalds.**

**Children, disabled and elderly are at highest risk of being scalded.**

**See instruction manual before setting temperature at water heater.**

**Feel water before bathing or showering.**

**Temperature limiting valves are available, see manual.**

### Time/Temperature Relationship in Scalds



Water Temperature	Time To Produce a Serious Burn
120°F (49°C)	More than 5 minutes
125°F (52°C)	1½ to 2 minutes
130°F (54°C)	About 30 seconds
135°F (57°C)	About 10 seconds
140°F (60°C)	Less than 5 seconds
145°F (63°C)	Less than 3 seconds
150°F (66°C)	About 1½ seconds
155°F (68°C)	About 1 second

Table courtesy of Shriners Burn Institute

The chart shown above may be used as a guide in determining the proper water temperature for your home.

**⚠️ DANGER: Households with small children, disabled, or elderly persons may require a 120°F (49°C) or lower combination gas control (thermostat) setting to prevent contact with "HOT" water.**

Maximum water temperatures occur just after the burner has shut off. To find water temperature being delivered, turn on a hot water faucet and place a thermometer in the water stream and read the thermometer. (See pages 35 and 36 for more details.)

The temperature of the water in the heater can be regulated by pressing the "COOLER" or "HOTTER" arrow buttons   on the front of the combination gas control. To comply with safety regulations the combination gas control was set at its lowest setting before the water heater was shipped from the factory. The desired water temperature must be set.

The illustration below details the approximate water temperature for each LED indicator of the combination gas control's display.

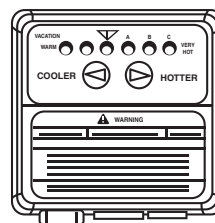

**⚠️ DANGER: Hotter water increases the potential for Hot Water SCALDS.**

**NOTICE:** Mixing valves are available for reducing point of use water temperature by mixing hot and cold water in branch water lines. Contact a licensed plumber or the local plumbing authority for further information.

Temperature Setting	Display ▼ A B C	Burns on Adult Skin
WARM = approx. 70°F (21°C)	● ○ ○ ○ ○ ○	-----
▼ = approx. 120°F (49°C)	○ ○ ● ○ ○ ○	More than 5 minutes
A = approx. 130°F (54°C)	○ ○ ○ ● ○ ○	About 30 seconds
B = approx. 140°F (60°C)	○ ○ ○ ○ ● ○	Less than 5 seconds
C = approx. 150°F (66°C)	○ ○ ○ ○ ○ ●	About 1-1/2 seconds
C-Flashing = approx. 160°F (71°C)	○ ○ ○ ○ ○ ●	About 1/2 seconds



# ⚠ DANGER!

## LIQUEFIED PETROLEUM (LP—PROPANE OR BUTANE) AND NATURAL GAS MODELS

LP and Natural gas have an odorant added to aid in detecting a gas leak. Some people may not physically be able to smell or recognize this odorant. If you are unsure or unfamiliar with the smell of LP or natural gas, ask the gas supplier. Other conditions, such as “odorant fade”, which causes the odorant to diminish in intensity, can also hide or camouflage a gas leak.

- Water heaters utilizing LP gas are different from natural gas models. A natural gas water heater will not function safely on LP gas and vice versa.
  - No attempt should ever be made to convert the water heater from natural gas to LP gas. To avoid possible equipment damage, personal injury or fire, DO NOT connect the water heater to a fuel type not in accordance with the unit data plate. LP for LP units. Natural gas for natural gas units. These units are not certified for any other fuel type.
  - LP appliances should not be installed below grade (for example, in a basement) if such installation is prohibited by federal, state and/or local laws, rules, regulations or customs.
  - LP gas must be used with great caution. It is heavier than air and will collect first in lower areas making it hard to detect at nose level.
  - Before attempting to light the water heater, make sure to look and smell for gas leaks. Use a soapy solution to check all gas fittings and connections. Bubbling at a connection indicates a leak that must be corrected. When smelling to detect a gas leak, be sure to sniff near the floor also.
  - Gas detectors are recommended in LP & natural gas applications and their installation should be in accordance with the detector manufacturer’s recommendations and/or local laws, rules, regulations or customs.
  - It is recommended that more than one method, such as soapy solution, gas detectors, etc., be used to detect leaks in gas applications.
- ⚠ DANGER: If a gas leak is present or suspected:
- **DO NOT** attempt to find the cause yourself.
  - **DO NOT** try to light any appliance.
  - **DO NOT** touch any electrical switch.
  - **DO NOT** use any phone in your building.
  - Leave the house immediately and make sure your family and pets leave also.
  - Leave the doors open for ventilation and contact the gas supplier, a qualified service agency or the fire department.
  - Stay away from the house (or building) until the service call has been made, the leak is corrected and a qualified agency has determined the area to be safe.

# IMPORTANT SAFETY INFORMATION. READ ALL INSTRUCTIONS BEFORE USING

---

## **WARNING!**

For your safety, the information in this manual must be followed to minimize the risk of fire or explosion, electric shock, or to prevent property damage, personal injury, or loss of life.



## FOR INSTALLATIONS IN THE STATE OF CALIFORNIA

---

California Law requires that residential water heaters must be braced, anchored or strapped to resist falling or horizontal displacement due to earthquake motions. For residential water heaters up to 52-gallon capacity, a brochure with generic earthquake bracing instructions can be obtained from: Office of the State Architect, 1102 Q Street, Suite 5100, Sacramento, CA 95814 or you may call 916-445-8100 or ask a water heater dealer.

However, applicable local codes shall govern installation. For residential water heaters of a capacity greater than 52 gallons, consult the local building jurisdiction for acceptable bracing procedures.



## SAFETY PRECAUTIONS

---

Have the installer show you the location of the gas shut-off valve and how to shut it off if necessary. Turn off the manual shut-off valve if the water heater has been subjected to overheating, fire, flood, physical damage or if the gas supply fails to shut off.

- Read this manual entirely before installing or operating the water heater.
- Use this appliance only for its intended purpose as described in this Use and Care Manual.
- Be sure your appliance is properly installed in accordance with local codes and the provided installation instructions.
- **DO NOT** attempt to repair or replace any part of your water heater unless it is specifically recommended in this manual. All other servicing should be referred to a qualified technician.



READ AND FOLLOW THIS SAFETY INFORMATION CAREFULLY.

---

## SAVE THESE INSTRUCTIONS

### IMPORTANT

Carefully inspect the water heater for damage before proceeding with the installation. Of specific interest should be any dents in the long blue cover panel for the combustion air-inlet, PVC pipe; or damages to the blower and the combustion air-inlet, PVC pipe assembly. If you find damage, **DO NOT** install or attempt any repair to the water heater. Contact the manufacturer as detailed under "IF YOU NEED SERVICE" on page 44.

# Installing the Water Heater

This water heater must be installed in accordance with these instructions, local codes, utility company requirements, and/or in the absence of local codes, use the latest edition of the American National Standard/National Fuel Gas Code. A copy can be purchased from either the American Gas Association, 400 N. Capitol Street NW, Washington, DC 20001 as ANSI standard Z223.1 or National Fire Protection Association, 1 Batterymarch Park, Quincy, MA 02269 as booklet NFPA 54.

## Location

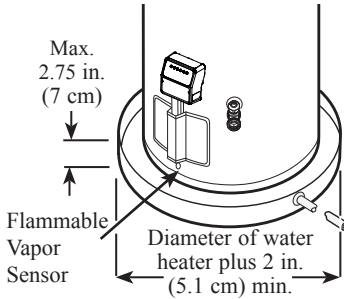

The auxiliary catch pan installation **MUST** conform with local codes.

**NOTICE: DO NOT** allow the catch pan to obstruct the flammable vapor sensor.

**NOTICE: DO NOT** allow the flammable vapor sensor to become submerged in water. Make sure the catch pan is properly drained.

**▲ WARNING: Combustible construction** refers to adjacent walls and ceilings and should not be confused with combustible or flammable products and materials. Combustible and/or flammable products and materials should never be stored in the vicinity of this or any gas appliance.

The water heater should not be located in an area where leakage from the tank or connections will result in damage to the area adjacent to the heater or to lower floors of the structure.

When such areas cannot be avoided it is recommended that a suitable catch pan, adequately drained, must be installed under the water heater.

The water heater must be centered in the catch pan.

Catch pan kits are available from the store where the water heater was purchased, or any water heater distributor.

Make certain the floor underneath the water heater is strong enough to sufficiently support the weight of the water heater once it is filled with water.

This gas-fired water heater or any other appliance should not be installed in a space where liquids which give off flammable vapors are to be used or stored. Such liquids include gasoline, LP gas (butane or propane), paint or adhesives, thinners, solvents and/or combustible removers.

**DO NOT** obstruct or block the Flammable Vapor Sensor.

Because of natural air movement in a room or other enclosed space, flammable vapors can be carried some distance from where liquids which give off flammable vapors are to be used or stored. The open flame of the water heater's main burner can ignite these vapors creating a shut down condition which will not allow the water heater to ignite.

Rheem Water Heating FVIR certified gas water heaters can be installed on a residential garage floor without the use of an 18 in. (46 cm.) stand in accordance with the National Fuel Gas Code, ANSI Z223.1/NFPA 54, unless otherwise directed by State and Local code requirements. The water heater must be located so it is not

subject to physical damage, for example, by moving vehicles, area flooding, etc.

- We recommend this water heater be installed in locations where the ambient temperatures **DO NOT** exceed 100°F (38°C).

**IMPORTANT: DO NOT** install the water heater in a location where it may be subjected to ambient temperatures exceeding 125°F (52°C).

- The water heater should be installed so as to minimize the length of plastic vent and combustion air-inlet pipe and the number of vent and combustion air-inlet connection fittings required.
- See Vent and Combustion Air-Inlet Section for vent system requirements.
- Hot water lines should be insulated to conserve water and energy.
- Protect the water heater and water lines from exposure to freezing temperatures.
- **DO NOT** install this water heater outdoors.
- Minimum clearances from combustible construction:

FrontV	Sides	Rear	TopVV
5 in. (12.7 cm)	0 in. (0 cm)	0 in. (0 cm)	12 in. (30.5 cm)

V "Front" Clearance dimension is measured from the water heater jacket to the closet door.

VV "Top" clearance dimension is measured from the jacket top of the water heater to the ceiling.

- If the water heater is to be installed directly on carpeting, the water heater shall be installed on a metal or wood panel extending beyond the full width and depth of the water heater by at least 3 in. (7.6 cm) in all directions or, if the water heater is to be installed in an alcove or closet, the entire floor must be covered by a wood or metal panel.

# Installing the Water Heater

---

**NOTICE: The water heater must not be installed near an air supply containing halogenated hydrocarbons.**

## Corrosive Atmospheres

The air in beauty shops, dry cleaning establishments, photo processing labs, and storage areas for liquid and powdered bleaches or swimming pool chemicals often contain halogenated hydrocarbons.

An air supply containing halogenated hydrocarbons may be safe to breathe, but when it passes through a gas flame corrosive elements

are released that will shorten the life of any gas burning appliance.

Propellants from common spray cans or gas leaks from A/C and refrigeration equipment are highly corrosive after passing through a flame.

The water heater warranty is voided when failure of the heater is due to operation in a corrosive atmosphere.

---

## Thermal Expansion

Determine if a check valve exists in the inlet water line. Check with your local water utility company. It may have been installed in the cold water line as a separate back flow preventer, or it may be part of a pressure reducing valve, water meter or water softener. A check valve located in the cold water inlet line can cause what is referred to as a “**closed water system**”. A cold water inlet line with no check valve or back flow prevention device is referred to as an “**open**” water system.

As water is heated, it expands in volume and creates an increase in the pressure within the water system. This action is referred to as “**thermal expansion**”. In an “**open**” water system, expanding water which exceeds the capacity of the water heater flows back into the city main where the pressure is easily dissipated.

A “**closed water system**”, however, prevents the expanding water from flowing back into the main supply line, and the result of “**thermal expansion**” can create a rapid and dangerous pressure increase in the water heater and system

pipng. This rapid pressure increase can quickly reach the safety setting of the relief valve, causing it to operate during each heating cycle.

Thermal expansion, and the resulting rapid, and repeated expansion and contraction of components in the water heater and piping system can cause premature failure of the relief valve, and possibly the heater itself. Replacing the relief valve will not correct the problem!

The suggested method of controlling thermal expansion is to install an expansion tank in the cold water line between the water heater and the check valve (see illustration on page 9). The expansion tank is designed with an air cushion built in that compresses as the system pressure increases, thereby relieving the over pressure condition and eliminating the repeated operation of the relief valve. Other methods of controlling thermal expansion are also available. Contact your installing contractor, water supplier or plumbing inspector for additional information regarding this subject.

---

## Water Supply Connections

Refer to the following illustration for suggested typical installation. The installation of unions or flexible copper connectors are recommended on the hot and cold water connections so that the water heater may be easily disconnected for servicing if necessary. The HOT and COLD water connections are clearly marked on the water heater. Install a shutoff valve in the cold water line near the water heater. Refer to the following illustration for suggested typical installation.

**IMPORTANT: DO NOT apply heat to the HOT or COLD water connections. If sweat connections are used, sweat tubing to adapter before fitting adapter to the cold water connections on heater. Any heat applied to the cold water supply fittings will permanently damage the dip tube and heat traps.**

### IMPORTANT

For models equipped with a Top Cap, it is recommended that the hot and cold water piping have a minimum vertical height of 10 inches (25.4 cm) from the top of the water heater before transitioning into any elbow. This vertical height is needed in order to provide adequate clearance for Top Cap installation and removal.

To gain access to the hot and cold water connections on models equipped with a Top Cap, remove the two (2) screws that secure the top cap to the water heater then pull the Top Cap upward and off the water heater. See illustration of Top Cap and screws on pages 31 & 43.

## Typical Installation

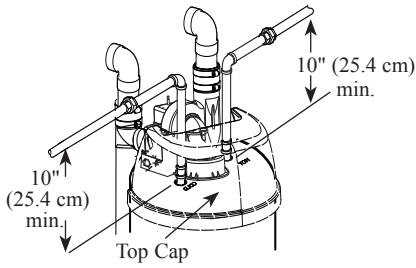

**Alternate installation detail for models equipped with a Top Cap.**

**NOTICE: The National Fuel Gas Code (NFPA) mandates a manual gas shut-off valve: See (NFPA) for complete instructions. Local codes or plumbing authority requirements may vary from the instructions or diagrams provided and take precedent over these instructions.**

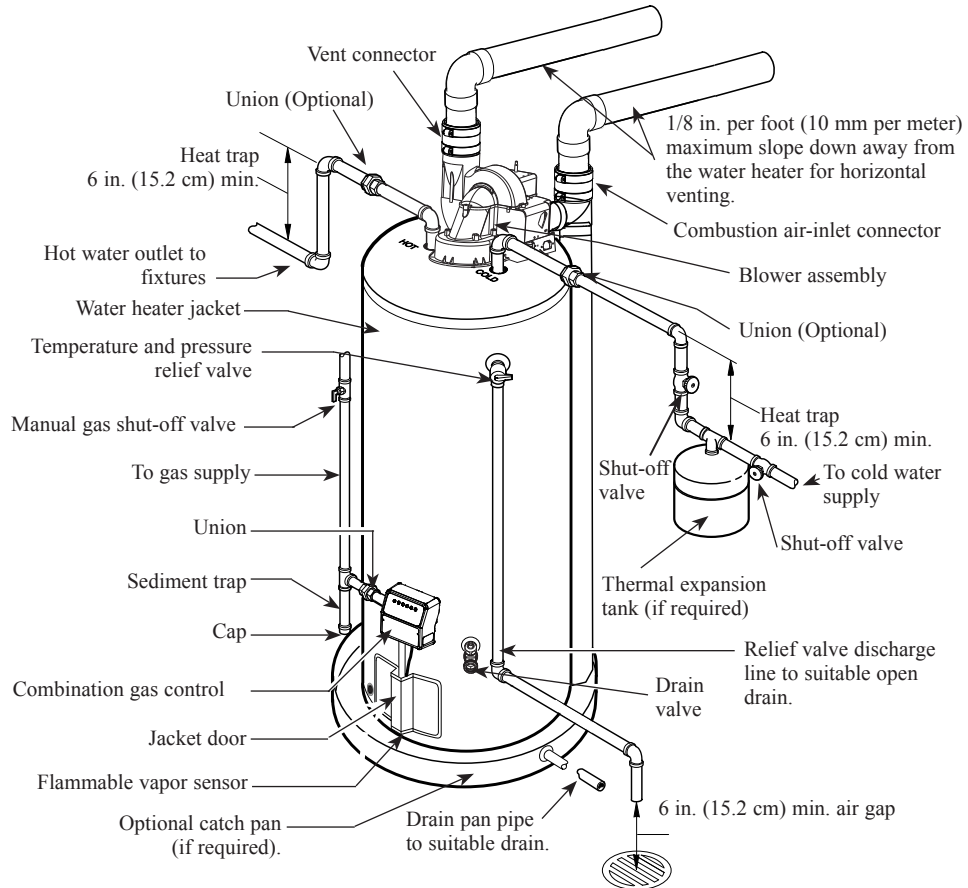

**A new combination temperature and pressure relief valve, complying with the Standard for Relief Valves and Automatic Gas Shut-Off Devices for Hot Water Supply Systems, ANSI Z21.22 /CSA 4.4, is factory installed and must remain in the opening provided and marked for the purpose on the water heater. No valve of any type should be installed between the relief valve and the tank. Local codes shall govern the installation of relief valves.**

### Relief Valve

The pressure rating of the relief valve must not exceed 150 psi (1,034 kPa), the maximum working pressure of the water heater as marked on the rating plate.

The Btuh rating of the relief valve must equal or exceed the Btuh input of the water heater as marked on its rating plate.

Position the outlet of the relief valve above a suitable open drain to eliminate potential water damage. Piping used should be of a type approved for hot water distribution.

The discharge line must be no smaller than the outlet of the valve and must pitch downward from the valve to allow complete drainage (by gravity) of the relief valve and discharge line.

The end of the discharge line should not be threaded or concealed and should be protected from freezing. No valve of any type, restriction, or reducer coupling must be installed in the discharge line.

# Installing the Water Heater

---

**▲WARNING:**  
The tank must be full of water before the water heater is turned on. The water heater warranty does not cover damage or failure resulting from operation with an empty or partially empty tank.

## To Fill the Water Heater

Make certain that the drain valve is closed, then open the shut-off valve in the cold water supply line.

Open each hot water faucet slowly to allow the air to vent from the water heater and piping.

A steady flow of water from all hot water faucet(s) indicates a full water heater.

**DO NOT** allow the flammable vapor sensor to become submerged in water.

---

## Condensation

Condensation can also form on the tank when it is first filled with water. Condensation might also occur with a heavy water draw and very cold inlet water temperatures. Drops of water falling on the burner can produce a sizzling or pinging sound. This condition is not

unusual, and will disappear after the water becomes heated. However, if condensation continues, examine the piping and fittings for possible leaks.

---

## Gas Supply

The branch gas supply line to the water heater should be clean properly sized steel pipe or other approved gas piping material.

A union or ANSI design certified semi-rigid or flexible gas appliance connector should be installed in the gas line close to the water heater. The National Fuel Gas Code (NFGC) mandates a manual gas shutoff valve: See (NFGC) for complete instructions.

If flexible connectors are used, the maximum length shall not exceed 36 in. (91.4 cm) and must meet the requirements in ANSI Z21.24/ CSA 6.10- Connectors for Gas Appliances.

Compound used on the threaded joints of the gas piping must be of the type resistant to the action of LP gas. Use compound sparingly on male threads only.

Where a sediment trap is not incorporated as part of the appliance, a sediment trap shall be installed downstream of the equipment shutoff

valve as close to the inlet of the appliance as practical at the time the appliance installation. The sediment trap shall be either a tee fitting with a capped nipple in the bottom outlet or other device recognized as an effective sediment trap.

**DO NOT** use excessive force over 31.5 ft. lbs. (42.7 N•m) in tightening the pipe joint at the combination gas control inlet, particularly if teflon pipe compound is used, as the valve body may be damaged.

The inlet gas pressure to the water heater must not exceed 14.0 in. w.c. (3.5 kPa) w.c. for natural gas, or 14.0 in. w.c. (3.5 kPa) w.c. for LP gas. For purposes of input adjustment, the minimum inlet gas pressure (with main burner on) is shown on the water heater rating plate. If high or low gas pressures are present, contact your gas supplier for correction.

**▲WARNING:**  
DO NOT attempt to convert this water heater for use with a different type of gas other than the type shown on the rating plate. Such conversion could result in hazardous operating conditions.

---

## Leak Testing

The water heater and its gas connections must be leak tested at normal operating pressures before it is placed in operation.

**1** Turn on the manual gas shut-off valve near the water heater.

**2** Use a soapy water solution to test for leaks at all connections and fittings. Bubbles indicate a gas leak that must be corrected.

The factory connections to the combination gas control should also be leak tested after the water heater is placed in operation.

**▲WARNING:**  
Never use an open flame to test for gas leaks, as property damage, personal injury, or death could result.

---

## Pressure Testing the Gas Supply System

The water heater and its individual shut-off valve must be disconnected from the gas supply piping system during any pressure testing of that system at test pressures in excess 1/2 psi (3.5 kPa).

The water heater must be isolated from the gas supply piping system by closing its individual manual gas shutoff valve during any pressure testing of the gas supply at test pressures equal to or less than 1/2 psi (3.5 kPa).

---

**▲WARNING:** Failure to install a water heater suitable for the altitude at the location it is intended to serve, can result in improper operation of the appliance resulting in property damage and/or producing carbon monoxide gas, which could result in personal injury, or death.

## High Altitude

Input rating of this water heater is based on sea level operation. At higher elevations the actual input rate may be lower than the value listed on the rating label due to the derating of Natural Gas and LP Gas. For Power Direct Vent models listed in the venting tables that **DO NOT** show venting

configurations above 7,700 ft. (2,347 m), contact the water heater manufacturer for a required High Altitude Kit that will allow the specific water heater model to operate at altitudes between 7,700 ft. (2,347 m) and 10,200 ft. (3,109 m). See page 44.

---

**▲DANGER:** Failure to properly install the vent and combustion air-inlet systems as outlined in the Vent and Combustion Air-Inlet section of this manual will result in unsafe operation of the water heater causing bodily injury, explosion, fire or death.

To avoid the risk of fire, explosion, or asphyxiation from carbon monoxide, NEVER operate the water heater unless it is properly vented and the vent and combustion air-inlet systems are properly installed as detailed in the "Vent and Combustion Air-Inlet" section of this manual.

The vent and combustion air inlet pipes must overlap a minimum of 1/2 in. (1.3 cm) at each joint. It is important that the vent and combustion air-inlet pipes engage fully into any pipe fitting and be kept in that position until the adhesive has fully cured. **DO NOT** drill or punch holes in the plastic pipe or fittings.

## Vent and Combustion Air-Inlet

This water heater is a direct vent appliance and must be installed so that all air for combustion is derived directly from the outside atmosphere and all flue gases are discharged to the outside atmosphere. For proper installation of the vent and combustion air-inlet systems, follow the instructions as detailed in this manual. **DO NOT** connect this water heater to an existing vent or chimney - it must be vented separately from all other appliances.

**NOTICE:** This water heater is approved to use the following materials for pipe of the vent and combustion air-inlet systems:

PVC (Schedule 40, Cellular Core, ASTM-F891)

PVC (DWV, ASTM-D2665 or CSA B181.2)

PVC (Schedule 40, ASTM-D1785 or CSA B137.3)

PVC (SDR Series, ASTM-D2241 or CSA B137.3)

CPVC (CPVC 4120, ASTM-D2846 or CSA B137.6)

CPVC (Schedule 40, ASTM-F441 or CSA B137.3)

CPVC (SDR Series, ASTM-F442)

ABS (Schedule 40, DWV, ASTM-D2661 or CSA B181.1)

ABS (Schedule 40, DWV, Cellular Core, ASTM-F628)

**This water heater is approved to use the following materials for the fittings of the vent and combustion air-intake systems:**

PVC (Schedule 40 DWV, ASTM D2665)

CPVC (Schedule 40, ASTM F438)

ABS (Schedule 40 DWV, ASTM D2661)

**DO NOT mix ABS pipe and fittings with PVC or CPVC pipe fittings. Note: It is acceptable to interchange PVC and CPVC pipe and fittings.**

Vent and combustion air-inlet systems must be adequately supported along both vertical and horizontal lengths.

The vent and combustion air-inlet systems of this water heater may be installed horizontally through a wall or vertically through the roof.

Maximum unsupported length is recommended to be no more than 4 feet (1.22 m).

It is imperative that the first hanger be located on the horizontal length immediately adjacent to the first 90-degree elbow from the vertical rise of vent pipe connected to the water heater.

# Installing the Water Heater

## Vent and Combustion Air-Inlet continued -

	Ambient Installation Temperatures and Vent System Material Specifications			
	Up to 100°F (38°C)		100°F (38°C) to 125°F (52°C)	
Models	0 to 10 ft. (0 to 3 m) Equivalent Vent System Length	10 ft. to Max. (3 m to Max.) Equivalent Vent System Length	0 to 10 ft. (0 to 3 m) Equivalent Vent System Length	10 ft. to Max. (3 m to Max.) Equivalent Vent System Length
40 gallon, 40,000 & 38,000 Btu/hr. Models	PVC, CPVC, or ABS		CPVC or ABS	PVC, CPVC, or ABS
50 Gallon, 40,000 Btu/hr. Models				
65 Gallon, 65,000 & 56,000 Btu/hr. Models				
50 Gallon, 65,000 & 47,000 Btu/hr. Models	CPVC or ABS	PVC, CPVC, or ABS		
75 Gallon, 75,100 & 70,000 Btu/hr. Models				

NOTICE: This water heater may be installed in attics provided ambient temperatures **DO NOT** exceed 125°F (52°C) and CPVC or ABS pipe and fittings are used for the entire vent system.

**NOTICE: This unit is equipped with a Flammable Vapor Sensor. DO NOT supply electrical power to the water heater until enough time has passed to allow the vapors from the primer and cement to dissipate.**

The support method used should isolate the vent and combustion air-inlet pipes from floor joists or other structural members to help prevent the transmission of noise and vibration.

**DO NOT** support, pin or otherwise secure the vent and combustion air-inlet systems in a way that restricts the normal thermal expansion and contraction of the chosen venting material.

If the water heater is being installed as a replacement for an existing power direct vent water heater, a thorough inspection of the existing vent and combustion air-inlet systems must be performed prior to any installation work.

- 1 Verify that the correct materials as specified in this manual have been used, and that the minimum or maximum vent and combustion air-inlet lengths and terminal

locations as detailed in this manual have been met.

- 2 Carefully inspect the entire vent and combustion air-inlet systems for any signs of cracks or fractures, particularly at the joints between elbows or other fittings and the straight length of vent pipe.
- 3 Check the vent and combustion air-inlet for signs of sagging or other stresses in the joints as a result of misalignment of any components in the systems.
- 4 If any of the conditions above are found, they must be corrected in accordance with the instructions in this manual before completing the installation and putting the water heater into service.

*Additional installation information for The Commonwealth of Massachusetts is located on the back page of this manual.*

## Maximum and Minimum Vent and Combustion Air-Inlet Lengths for Power Direct Vent Models:

### 40 Gallon with Inputs of 40,000 & 38,000 Btu/h 50 Gallon with Input of 40,000 Btu/h

Read these instructions thoroughly and make sure you understand all steps and procedures before proceeding with the installation.

1. Connect the vent system piping to the blower assembly using the already installed 2 in. (5.1 cm) diameter rubber coupling and clamps.
2. Connect the combustion air-inlet system piping to the combustion air-inlet piping tee using the 2 in. (5.1 cm) already installed rubber coupling and clamps (See Figure 1).
3. For vent and combustion air-inlet terminals, use the two (2), 2 in. (5.1 cm) diameter, Schedule 40, PVC, 90°, 1/4 standard bend elbows supplied with the water heater.

This water heater may also be installed with 3 in. (7.6 cm) diameter pipe and fittings for the vent and combustion air-inlet systems.

To connect the vent system piping:

- Install a straight length of 2 in. (5.1 cm) diameter pipe to the rubber coupling on the blower assembly,
- Followed by a 2 in. (5.1 cm) to 3 in. (7.6 cm) diameter pipe increaser fitting (See Figure 2).

To connect the combustion air-inlet system piping:

- Install a straight length of 2 in. (5.1 cm) diameter pipe to the combustion air-inlet piping tee coupling,
- Followed by a 2 in. (5.1 cm) to 3 in. (7.6 cm) diameter pipe increaser fitting (See Figure 2).

For vent and combustion air-inlet terminals,

- Use 3 in. (7.6 cm) diameter, Schedule 40, PVC, 90°, 1/4 standard bend elbows (not supplied).

**DO NOT** use unequal diameters of pipe and fittings for the vent and combustion air-inlet systems except as defined previously.

**NOTICE:** The difference between the vent and combustion air-inlet system equivalent lengths must be no greater than 5 ft. (1.5 m).

**IMPORTANT:** Ensure that all the coupling clamps are tightened before allowing the water heater to operate.

When using CPVC or ABS pipe and fittings, use 90° elbows of the corresponding size and material for the vent terminal and combustion air-inlet terminals.

**The vent and combustion air-inlet terminals of the water heater must be installed in the same atmospheric pressure zone.**

The minimum and maximum equivalent lengths for the vent and combustion air-inlet systems are shown in Table 1.

- Maintain a minimum vertical height of 1 ft. (30.5 cm) of pipe, including pipe increasers (if used), from the blower exhaust coupling before transitioning into any elbow.
- The vent and combustion air-inlet terminations are not included in the equivalency calculations.

**NOTICE:** A 90°, 1/4 standard bend or long bend elbow is equivalent to 5 ft. (1.52 m) of straight pipe. A 45°, 1/8 standard bend or long bend elbow is equivalent to 2.5 ft. (0.76 m) of straight pipe.

**DO NOT** use short bend elbows. Use only standard and/or long bend elbows. See examples below.

Elbow Examples

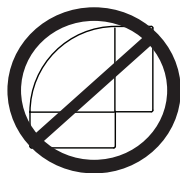

Short Bend 90° Elbow  
**DO NOT Use**

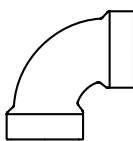

Standard Bend 90° Elbow  
**OK to Use**

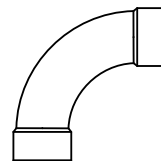

Long Bend 90° Elbow  
**OK to Use**

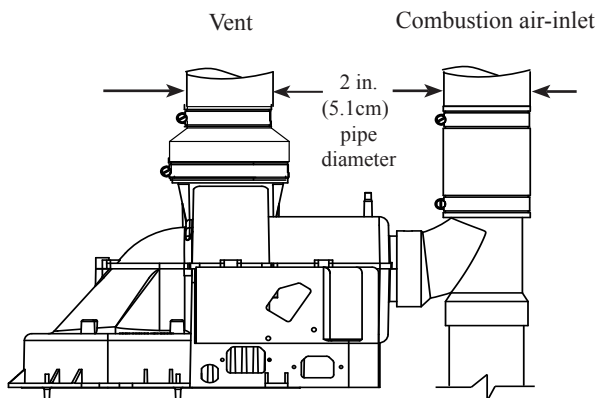

Figure 1

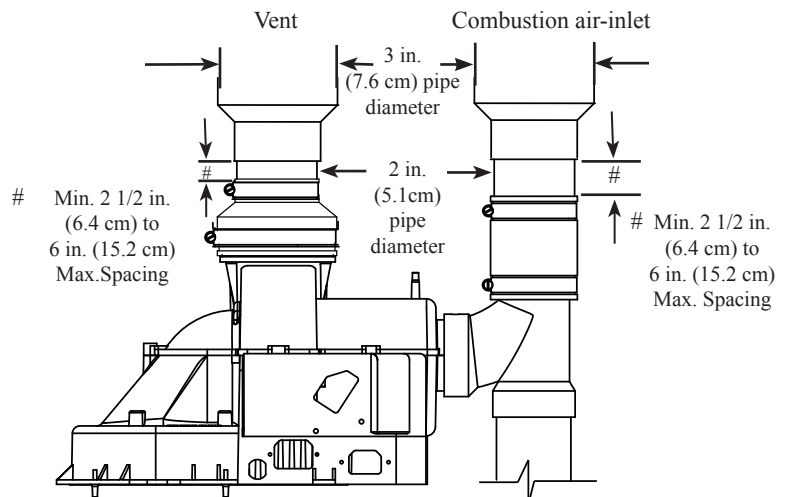

Figure 2

# Installing the Water Heater

<b>Table 1</b>							
<i>From Sea Level through 5,999 ft. (1,828 m) Above Sea Level</i>							
Model	Vent & Combustion Air-Inlet System Diameter	Min. Allowed Equivalent Vent & Combustion Air-Inlet Lengths (Each Pipe Run)		Max. Allowed Equivalent Vent & Combustion Air-Inlet Lengths (Each Pipe Run)		Vent and Combustion Air-Inlet System Termination(s)	
	Inches	Feet	Meters	Feet	Meters		
40 Gallon, 40,000 & 38,000 Btu/hr. Models	2	7	2	30	9	90° Elbows	Concentric*
	3	7	2	60	18	90° Elbows	
	3	7	2	50	15		Concentric*
50 Gallon, 40,000 Btu/hr. Models	2	7	2	30	9	90° Elbows	Concentric*
	3	7	2	60	18	90° Elbows	
	3	7	2	50	15		Concentric*
<i>From 6,000 ft. (1,828 m) Above Sea Level through 7,700 ft. (2,347 m) Above Sea Level</i>							
Model	Vent & Combustion Air-Inlet System Diameter	Min. Allowed Equivalent Vent & Combustion Air-Inlet Lengths (Each Pipe Run)		Max. Allowed Equivalent Vent & Combustion Air-Inlet Lengths (Each Pipe Run)		Vent and Combustion Air-Inlet System Termination(s)	
	Inches	Feet	Meters	Feet	Meters		
40 Gallon, 40,000 & 38,000 Btu/hr. Models	2	7	2	15	4.5	90° Elbows	
	2	7	2	30	9		Concentric*
	3	7	2	60	18	90° Elbows	
	3	7	2	50	15		Concentric*
50 Gallon, 40,000 Btu/hr. Models	2	7	2	15	4.5		Concentric*
	3	7	2	60	18	90° Elbows	
	3	7	2	50	15		Concentric*
<i>From 7,701 ft. (2,347 m) Above Sea Level through 10,200 ft. (3,109 m) Above Sea Level</i>							
Model	Vent & Combustion Air-Inlet System Diameter	Min. Allowed Equivalent Vent & Combustion Air-Inlet Lengths (Each Pipe Run)		Max. Allowed Equivalent Vent & Combustion Air-Inlet Lengths (Each Pipe Run)		Vent and Combustion Air-Inlet System Termination(s)	
	Inches	Feet	Meters	Feet	Meters		
40 Gallon, 40,000 & 38,000 Btu/hr. Models	2	7	2	15	4.5		Concentric*
	3	7	2	60	18	90° Elbows	
	3	7	2	50	15		Concentric*
50 Gallon, 40,000 Btu/hr. Models	3	7	2	60	18	90° Elbows	
	3	7	2	50	15		Concentric*

**\*Use only Rheem 3 in. (7.6 cm) concentric termination.**

## Maximum and Minimum Vent and Combustion Air-Inlet Lengths For Power Direct Vent Models:

**50 Gallon With Inputs of 65,000 & 47,000 Btu/h**

**65 Gallon With Inputs of 65,000 & 56,000 Btu/h**

**75 Gallon With Inputs of 75,100 & 70,000 Btu/h**

Read these instructions thoroughly and make sure you understand all steps and procedures before proceeding with the installation.

1. Connect the vent system piping to the blower assembly using the already installed 3 in. (7.6 cm) diameter rubber coupling and clamps.
2. Connect the combustion air-inlet system piping to the combustion air-inlet piping tee using the 3 in. (7.6 cm) already installed rubber coupling and clamps (See Figure 3).
3. For vent and combustion air-inlet terminals, use the two (2), 3 in. (7.6 cm) diameter, Schedule 40, PVC, 90°, 1/4 standard bend elbows supplied with the water heater.

This water heater may also be installed with 4 in. (10.2 cm) diameter pipe and fittings for the vent and combustion air-inlet systems

To connect the vent system piping,

- Install a straight length of 3 in. (7.6 cm) diameter pipe to the rubber coupling on the blower assembly,
- Followed by a 3 in. (7.6 cm) to 4 in. (10.2 cm) diameter pipe increaser fitting (See Figure 4).

To connect the combustion air-inlet system piping,

- Install a straight length of 3 in. (7.6 cm) diameter pipe to the combustion air-inlet piping tee coupling,
- Followed by a 3 in. (7.6 cm) to 4 in. (10.2 cm) diameter pipe increaser fitting (See Figure 4).

For vent and combustion air-inlet terminals,

- Use 3 in. (7.6 cm) diameter, Schedule 40, PVC, 90°, 1/4 standard bend elbows (not supplied).

**DO NOT** use unequal diameters of pipe and fittings for the vent and combustion air-inlet systems except as defined previously.

**NOTICE: The difference between the vent and combustion air-inlet system equivalent lengths must be no greater than 5 ft. (1.5 m).**

**IMPORTANT:** Ensure that all the coupling clamps are tight before allowing the water heater to operate.

When using CPVC or ABS pipe and fittings, use 90° elbows of the corresponding size and material for the vent terminal and combustion air-inlet terminals.

The vent and combustion air-inlet terminals of the water heater must be installed in the same atmospheric pressure zone.

The minimum and maximum equivalent lengths for the vent and combustion air-inlet systems are shown in Table 2.

- Maintain a minimum vertical height of 1 ft. (30.5 cm) of pipe, including pipe increasers (if used), from the blower exhaust coupling before transitioning into any elbow.
- The vent and combustion air-inlet terminations are not included in the equivalency calculations.

**NOTICE: A 90°, 1/4 standard bend or long bend elbow is equivalent to 5 ft. (1.52 m) of straight pipe. A 45°, 1/8 standard bend or long bend elbow is equivalent to 2.5 ft. (0.76 m) of straight pipe.**

**DO NOT** use short bend elbows. Use only standard and/or long bend elbows. See examples below.

Elbow Examples

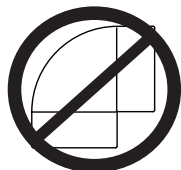

Short Bend 90° Elbow  
**DO NOT Use**

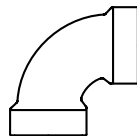

Standard Bend 90° Elbow  
**OK to Use**

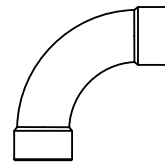

Long Bend 90° Elbow  
**OK to Use**

# Installing the Water Heater

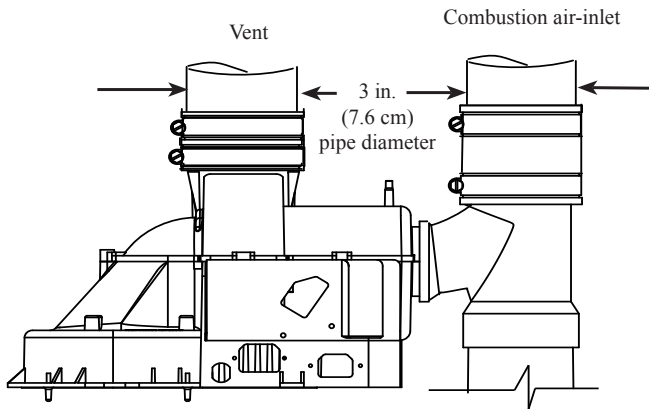

Figure 3

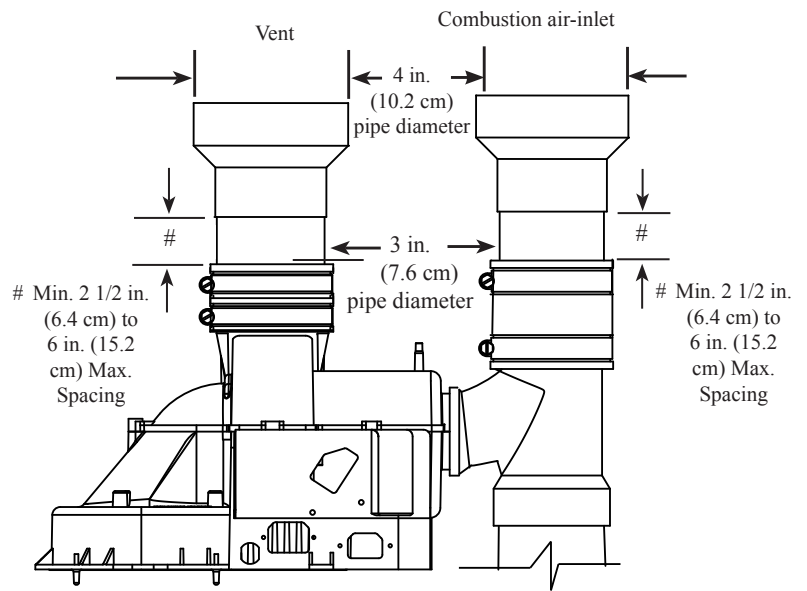

Figure 4

Table 2							
From Sea Level through 2,000 ft. (609 m) Above Sea Level							
Model	Vent & Combustion Air-Inlet System Diameter	Min. Allowed Equivalent Vent & Combustion Air-Inlet Lengths (Each Pipe Run)		Max. Allowed Equivalent Vent & Combustion Air-Inlet Lengths (Each Pipe Run)		Vent and Combustion Air-Inlet System Termination(s)	
		Feet	Meters	Feet	Meters		
50 Gallon, 65,000 & 47,000 Btu/hr. Models	3	7	2	50	15	90° Elbows	
	3	7	2	40	12		Concentric*
	4	7	2	100	30	90° Elbows	
65 Gallon, 65,000 & 56,000 Btu/hr. Models	3	8	2.5	50	15	90° Elbows	
	3	8	2.5	40	12		Concentric*
	4	8	2.5	100	30	90° Elbows	
75 Gallon, 75,100 & 70,000 Btu/hr. Models	3	8	2.5	50	15	90° Elbows	
	3	8	2.5	40	12		Concentric*
	4	8	2.5	100	30	90° Elbows	

\*Use only Rheem 3 in. (7.6 cm) concentric termination.

**Table 2 - Continued**

***From 2,000 ft. (609 m) Above Sea Level through 5,999 ft. (1,828 m) Above Sea Level***

Model	Vent & Combustion Air-Inlet System Diameter	Min. Allowed Equivalent Vent & Combustion Air-Inlet Lengths (Each Pipe Run)		Max. Allowed Equivalent Vent & Combustion Air-Inlet Lengths (Each Pipe Run)		Vent and Combustion Air-Inlet System Termination(s)	
	Inches	Feet	Meters	Feet	Meters		
50 Gallon, 65,000 & 47,000 Btu/hr. Models	3	7	2	50	15	90° Elbows	
	3	7	2	40	12		Concentric*
	4	7	2	100	30	90° Elbows	
65 Gallon, 65,000 & 56,000 Btu/hr. Models	3	8	2.5	30	9	90° Elbows	
	3	8	2.5	20	6		Concentric*
	4	8	2.5	100	30	90° Elbows	
75 Gallon, 75,100 & 70,000 Btu/hr. Models	3	8	2.5	25	8	90° Elbows	
	3	8	2.5	20	6		Concentric*
	4	8	2.5	100	30	90° Elbows	

***From 6,000 ft. (1,829 m) Above Sea Level through 7,700 ft. (2,347 m) Above Sea Level***

Model	Vent & Combustion Air-Inlet System Diameter	Min. Allowed Equivalent Vent & Combustion Air-Inlet Lengths (Each Pipe Run)		Max. Allowed Equivalent Vent & Combustion Air-Inlet Lengths (Each Pipe Run)		Vent and Combustion Air-Inlet System Termination(s)	
	Inches	Feet	Meters	Feet	Meters		
50 Gallon, 65,000 & 47,000 Btu/hr. Models	3	7	2	50	15	90° Elbows	
	3	7	2	40	12		Concentric
	4	7	2	100	30	90° Elbows	
65 Gallon, 65,000 & 56,000 Btu/hr. Models	4	8	2.5	40	12	90° Elbows	
75 Gallon, 75,100 & 70,000 Btu/hr. Models	4	8	2.5	50	15	90° Elbows	

***From 7,701 ft. (2,347 m) Above Sea Level through 10,200 ft. (3,109 m) Above Sea Level***

Model	Vent & Combustion Air-Inlet System Diameter	Min. Allowed Equivalent Vent & Combustion Air-Inlet Lengths (Each Pipe Run)		Max. Allowed Equivalent Vent & Combustion Air-Inlet Lengths (Each Pipe Run)		Vent and Combustion Air-Inlet System Termination(s)	
	Inches	Feet	Meters	Feet	Meters		
50 Gallon, 65,000 & 47,000 Btu/hr. Models	3	7	2	25	8	90° Elbow	
	3	7	2	20	6		Concentric*
	4	7	2	100	30	90° Elbow	

\*Use only Rheem 3 in. (7.6 cm) concentric termination.

# Installing the Water Heater

## Direct Vent Terminal Clearances

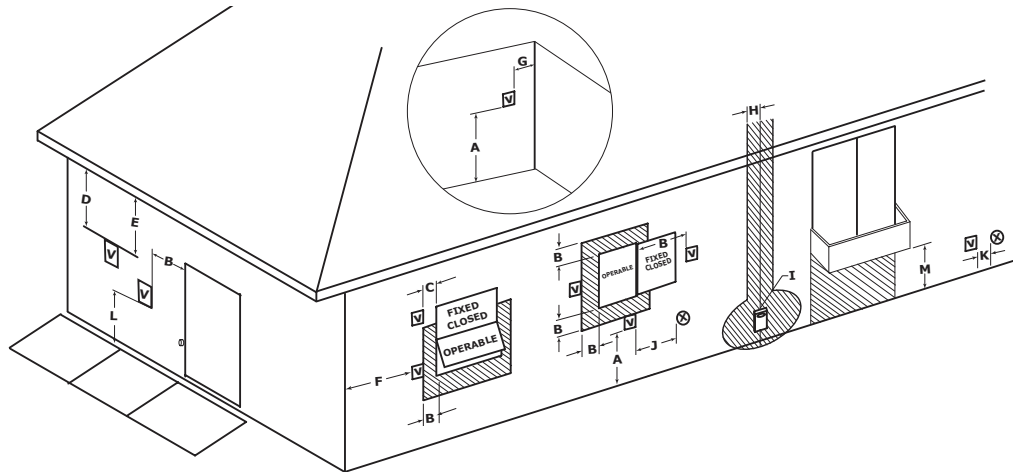

<input type="checkbox"/> Vent Terminal	<input type="checkbox"/> Air Supply Inlet	<input type="checkbox"/> Area Where Terminal Is Not Permitted
US Installations <sup>1</sup>		
A = Clearance above grade, veranda, porch, deck or balcony	1 ft. (30 cm)	
B = Clearance to window or door that may be opened	6 in. (15 cm) for appliances ≤ 10,000 Btuh (3 kW), 9 in. (23 cm) for appliances > 10,000 Btuh (3kW) and ≤ 50,000 Btuh (15 KW), 12 in. (30 cm) for appliances > 50,000 Btuh (15 kW)	
C = Clearance to permanently closed window		*
D = Vertical clearance to ventilated soffit located above the terminal within a horizontal distance of 2 feet (61 cm) from the center line of the terminal		*
E - Clearance to unventilated soffit		*
F - Clearance to outside corner		*
G - Clearance to inside corner		*
H - Clearance to each side of centerline extended above meter/regulator assembly		*
I - Clearance to service regulator vent outlet		*
J - Clearance to nonmechanical air supply inlet to building or the combustion air inlet to any other appliance	6 in. (15 cm) for appliances ≤ 10,000 Btuh (3 kW), 9 in. (23 cm) for appliances > 10,000 Btuh (3kW) and ≤ 50,000 Btuh (15 KW), 12 in. (30 cm) for appliances > 50,000 Btuh (15 kW)	
K - Clearance to a mechanical air supply inlet	3 ft. (91 cm) above if within 10 ft. (3 m) horizontally	
L - Clearance above paved sidewalk or paved driveway located on public property		*
M - Clearance under veranda, porch, deck, or balcony		*
<sup>1</sup> In accordance with the current ANSI Z223.1/ NFPA 54 National Fuel Gas Code * For clearances not specified in ANSI Z223.1/ NFPA 54 the following statement shall be included: "Clearance in accordance with local installation codes and the requirements of the gas supplier and the manufacturer's installation instructions".		

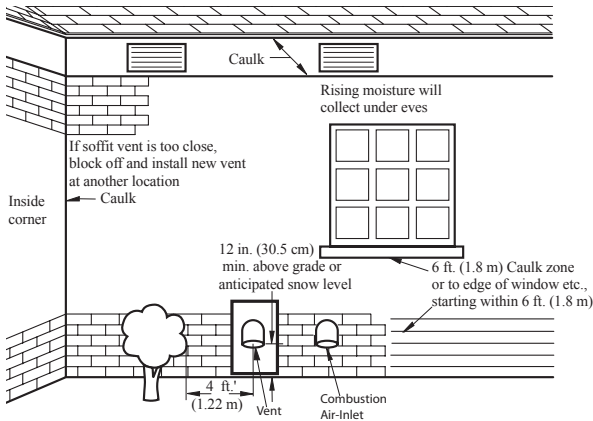

**⚠ WARNING: Moisture in the flue gas will condense as it leaves the vent terminal. In cold weather this condensate can freeze on the exterior wall, under the eaves and on surrounding objects. Some discoloration to the exterior of the building is to be expected. However, improper location or installation can result in severe damage to the structure or exterior finish of the building**

## Vent Terminal Location Considerations

- 1 **DO NOT** install the vent terminal under any patio or deck.
- 2 To help prevent moisture from freezing on walls and under eaves, **DO NOT** locate the vent terminal on the side of a building with prevailing winter winds.
- 3 When terminating the vent and combustion air-inlet pipes through brick or masonry surfaces, the installation of a rust resistant sheet metal backing plates behind the vent and combustion air-inlet terminals are recommended.
- 4 **DO NOT** locate the vent terminal too close to shrubbery, as flue gasses may damage them.
- 5 Caulk all cracks, seams and joints within 6 ft. (1.83 m) of the vent and combustion air-inlet terminals.
- 6 Insulate vent pipe exposed to cold conditions (attics, crawl spaces, etc.) with inflammable material to help prevent moisture from accumulating in the vent pipe.
- 7 Support horizontal sections of the vent and combustion air-inlet pipe every 4 ft. (1.22 m). **DO NOT** rigidly secure the vent system. Provisions must be made to allow for expansion and contraction of the vent system.
- 8 **DO NOT** install the vent and combustion air-inlet terminals less than 1 ft. (30 cm) above grade or average snowfall whichever is greater.
- 9 Permanently seal annular openings around the vent and combustion air-inlet system penetrations using approved materials to prevent entry of combustion products into the building.

## Horizontal Vent and Combustion Air-Inlet Terminal Installation

Read these instructions thoroughly and make sure you understand all steps and procedures before proceeding with the installation.

Determine the locations for the vent and combustion air-inlet terminals then make two (2) holes through the exterior wall to accommodate the vent and combustion air-inlet pipes.

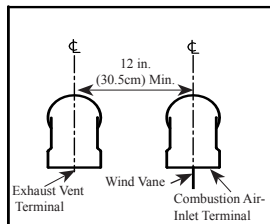

- Maintain a minimum horizontal distance of 12 in. (30.5 cm) between the vent and combustion air-inlet terminal centerlines.

Insert lengths of vent and combustion air-inlet pipes through the wall as shown.

- Allow sufficient length of pipe to extend beyond the exterior wall of the building for attachment of the vent and combustion air-inlet terminals.

Place the supplied 1/2 in. (1.3 cm) mesh metal screens inside each terminal fitting.

**NOTICE: For cold climates the screens may be removed.**

Connect the terminals to the vent and combustion air-inlet pipes which are extending out of the building.

- Ensure that the back of the supplied terminals are flush with the outside wall surface.

Complete the installation of the remainder of the vent system and attach it to the vent connector fitting on the water heater's blower assembly.

- **Horizontal lengths of the vent system must slope downward a minimum of 1/8 in. per foot (10 mm per m);**

**IMPORTANT:** When the vent system cannot be sloped away from the water heater or, if the vent system has vertical section(s), then all hori-

# Installing the Water Heater

## Horizontal Vent and Combustion Air-Inlet Terminal Installation continued -

zontal sections must slope upwards a minimum of 1/8 in. per foot (10 mm per m);

**DO NOT** use unequal diameters of pipe and fittings for the vent and combustion air-inlet systems except as defined previously

**NOTICE: The difference between the vent and combustion air-inlet system equivalent lengths must be no greater than 5 ft. (1.5 m).**

Complete the installation of the remainder of the combustion air-inlet system and attach it to the combustion air-inlet connector fitting on the water heater's combustion air-inlet tube assembly.

Support vertical and horizontal lengths of the vent and combustion air-inlet systems as previously mentioned.

### For 75 Gallon Power Direct Vent Models ONLY:

These water heater models are supplied with two (2) vent and combustion air-inlet termination restrictors. These restrictors help the water heater achieve peak efficiency when the water heater is installed using 3 in. (7.6 cm) diameter pipe at the minimum equivalent vent and combustion air-inlet lengths of 8 ft. (2 m).

**IMPORTANT: DO NOT** install the termination restrictors in equivalent vent and/or combustion air-inlet lengths longer than 8 ft. (2 m) or on any other Power Direct Vent model.

**NOTICE: Termination Restrictors supplied for use with 75 Gallon models ONLY.**

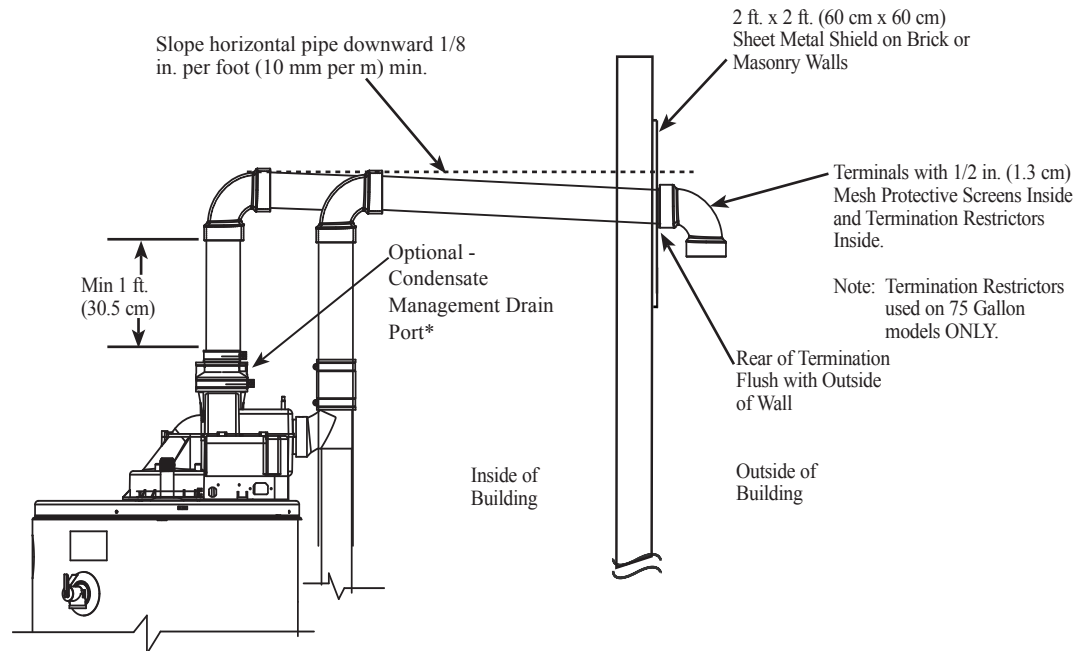

### Horizontal Vent and Combustion Air-Inlet Terminal Installation

\*See Condensate Management Section for additional information about optional piping.

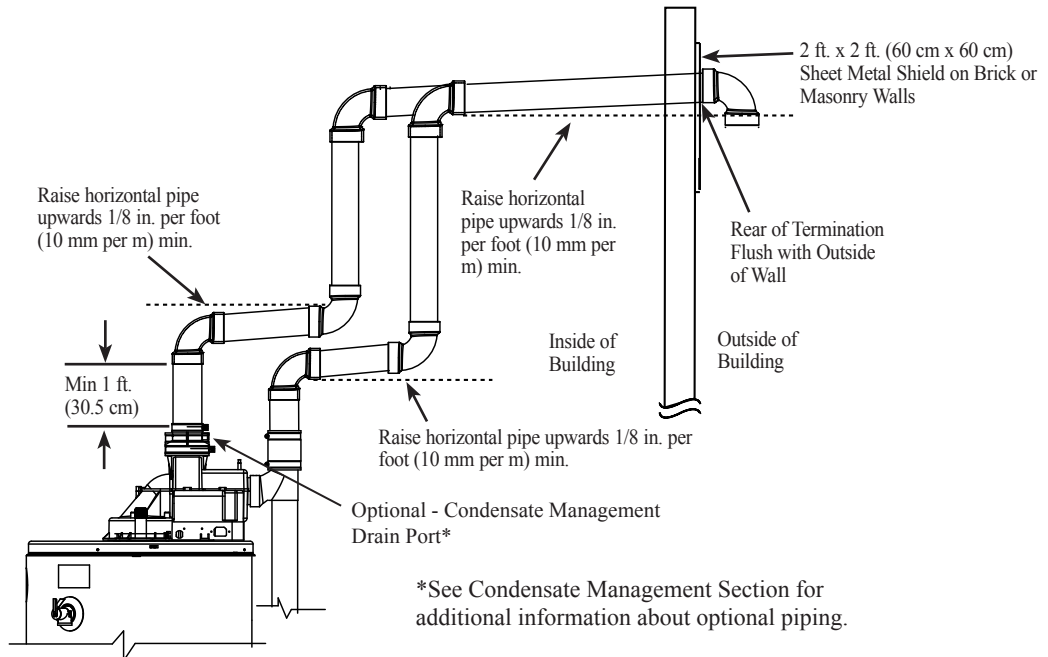

**Alternate Horizontal Vent and Combustion Air-Inlet Terminal Installation**

## Horizontal Vent and Combustion Air-Inlet Alternate Vent Riser Terminal Installation

### (40, 50, & 65 Gallon Models ONLY)

Read these instructions thoroughly and make sure you understand all steps and procedures before proceeding with the installation.

Determine the locations for the vent and combustion air-inlet terminals then make two (2) holes through the exterior wall to accommodate the vent and combustion air-inlet pipes.

- Maintain a minimum horizontal distance of 1 ft. (30.5 cm) between the vent and combustion air-inlet terminal centerlines.
- Maintain a minimum distance from the vent and combustion air-inlet terminals of not less than 1 ft. (30.5 cm) above grade or average snowfall whichever is greater.

Insert lengths of vent and combustion air-inlet pipes through the wall as shown.

- Allow sufficient length of pipe to extend beyond the exterior wall of the building for attachment of the vent riser assemblies as shown.

Place the supplied 1/2 in. (1.3 cm) mesh metal screens inside each terminal fitting.

**NOTICE: For cold climates the screens may be removed.**

Connect the vent riser assemblies to the vent and combustion air-inlet pipes which are extending out of the building.

- Ensure that the back of the 90° elbows are flush with the outside wall surface and that the vent and combustion air-inlet terminations of the vent risers are parallel with the outside wall.

**IMPORTANT:** Remember to include the additional 90° elbows and vertical height of vent and combustion air-inlet pipes of the vent riser when calculating the maximum equivalent vent and combustion air-inlet system lengths. The maximum equivalent vent and combustion air-inlet system lengths must be as specified by Table 1 or 2.

- The vent and combustion air-inlet terminations are not included in the equivalency calculations.

# Installing the Water Heater

Complete the installation of the remainder of the vent system and attach it to the vent connector fitting on the water heater's blower assembly.

- **Horizontal sections of the vent system must slope downward toward the water heater a minimum of 1/8 in. per foot (10 mm per m).**

**DO NOT** use unequal diameters of pipe and fittings for the vent and combustion air-inlet systems except as defined previously

**NOTICE: The difference between the vent and combustion air-inlet system equivalent lengths must be no greater than 5 ft. (1.5 m).**

Complete the installation of the remainder of the combustion air-inlet system and attach it to the combustion air-inlet connector fitting on the water heater's combustion air-inlet tube assembly.

Support vertical and horizontal lengths of the vent and combustion air-inlet systems as previously mentioned.

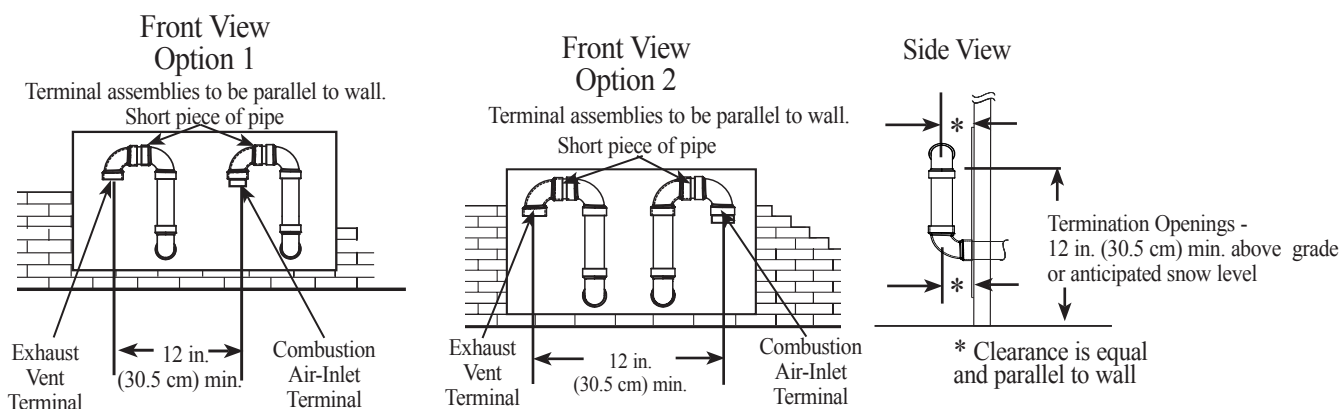

## Horizontal Vent- Alternate Concentric Terminal Installation: *Contact Manufacturer's National Service Department for Kit information, see "If You Need Service" section.*

Read these instructions thoroughly and make sure you understand all steps and procedures before proceeding with the installation.

Determine the location for the concentric terminal then make a 5 in. (12.7 cm) hole through the exterior wall.

Disassemble the concentric terminal assembly.

- Note: The concentric terminal assembly consists of an inner, straight vent pipe, an outer, straight combustion air-inlet pipe, a Wye fitting and rain cap.

The concentric terminal assembly is designed to accept 3 in. (7.6 cm) diameter pipe.

If 2 in. (5.1 cm) diameter pipe is used:

- Then either 2 in. x 3 in. (5.1 cm x 7.6 cm) pipe increasers,
- Or flush bushings must be installed to the vent and combustion air-inlet connections of the terminal assembly.
- **DO NOT** use the concentric terminal assembly with 4 in. (10.2 cm) vent and combustion air-inlet systems.

From inside the building, insert the outer, straight combustion air-inlet pipe through the wall so that the rear of the rain cap when installed sits flush with the outside wall.

**NOTICE: The concentric terminal assembly may be reduced in length as follows:**

- Measure for desired installation length then cut the outer, straight combustion air-inlet pipe accordingly but not less than 12 in. (30 cm).

- Measure and cut the straight inner vent pipe of the concentric terminal assembly so it is 13 in. (5.1 cm) longer in length than the outer, straight combustion air-inlet pipe.
- Ensure that there is no insulation or debris in the pipe.

Assemble the vent pipe assembly.

- Clean and cement the rain cap to the inner, straight vent pipe.
- From the outside, slide the vent pipe with rain cap assembly through the combustion air-inlet pipe until the rear of the rain cap is flush with the outside wall.
- Clean and cement the rain cap to the combustion air-inlet pipe.
- Clean and cement a 3 in. (7.6 cm) diameter, SDR 35, PVC, 90°, 1/4 standard bend elbow to the rain cap. See below.

From the inside, clean and cement the Wye fitting to the vent and combustion air-inlet pipes of the termination assembly.

Complete the installation of the remainder of the vent system and attach it to the vent connector fitting on the water heater's blower assembly.

**IMPORTANT:** Raise all horizontal sections upwards a minimum of 1/8 in. per foot (10 mm per m). See below.

**DO NOT** use unequal diameters of pipe and fittings for the vent and combustion air-inlet systems except as defined previously

**NOTICE: The difference between the vent and combustion air-inlet system equivalent lengths must be no greater than 5 ft. (1.5 m).**

Complete the installation of the remainder of the combustion air-inlet system and attach it to the combustion air-inlet connector fitting on the water heater's combustion air-inlet tube assembly.

Support vertical and horizontal lengths of the vent and combustion air-inlet systems as previously mentioned.

**IMPORTANT:** Ensure that all the coupling clamps are tight before allowing the water heater to operate.

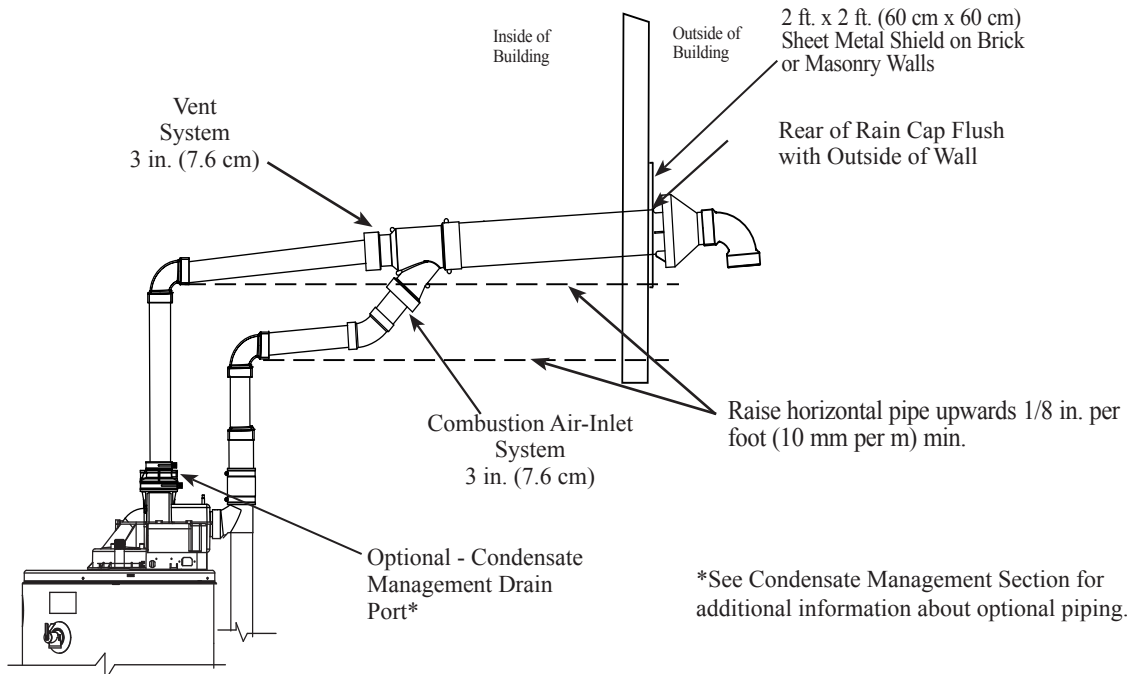

\*See Condensate Management Section for additional information about optional piping.

Horizontal Vent - Concentric Terminal Installation

# Installing the Water Heater

## Vertical Vent and Combustion Air-Inlet Installation

The location of the vent and combustion air-inlet terminals depends on the following minimum clearances and considerations.

- 1 Minimum 12 in. (30.5 cm) above roof.
- 2 Minimum 12 in. (30.5 cm) above anticipated snow level.
- 3 Maximum 24 in. (61cm) above roof level without additional support for vent.
- 4 Four (4) ft. (1.22 m) from any gable, dormer or other roof structure with building interior access (i.e., vent, window, etc.).
- 5 Ten (10) ft. (3.05m) from any forced air inlet to the building. Any fresh or make-up air inlet such as a dryer or furnace area is considered to be a forced air inlet.
- 6 Maintain a minimum horizontal distance of 12 in. (30.5 cm) between the vent and combustion air-inlet terminal centerlines.
- 7 Maintain a minimum distance from the vent and the combustion air-inlet terminals of not less than 12 in. (30.5 cm) above grade or average snowfall, whichever is greater.

Read these instructions thoroughly and make sure you understand all steps and procedures before proceeding with the installation.

Determine the locations for the vent and combustion air-inlet terminals then make two (2) holes through the roof and interior ceiling(s) to accommodate the vent and combustion air-inlet pipes.

- Maintain a minimum horizontal distance of 12 in. (3.5 cm) between the vent and combustion air-inlet terminals.

Assemble the vent pipe assembly.

Install the vent system and attach it to the vent connector fitting on the water heater's blower assembly.

**Horizontal lengths of the vent system must slope towards the water heater a minimum of 1/8 in. per foot (10 mm per m).**

Install the combustion air-inlet system and attach it to the combustion air-inlet connector fitting on the water heater's combustion air-inlet tube assembly.

- Support vertical and horizontal lengths of the vent and combustion air-inlet systems as previously mentioned.

Determine the vent and combustion air-inlet terminal heights and cut the pipe accordingly.

- Insert lengths of vent and combustion air-inlet pipes through the ceiling wall as shown.
- Install adequate flashing where the vent and combustion air-inlet pipes pass through the roof.
- Connect a short piece of pipe approximately 3 in. (7.6 cm) to the terminals and elbows.

Place the supplied 1/2 in. (1.3 cm) mesh metal screens inside each terminal fitting then connect a short piece of pipe approximately 3 in. (7.6 cm) between the terminals and elbows.

**NOTICE: For cold climates the screens may be removed.**

**For 75 Gallon Power Direct Vent Models ONLY:**

These water heater models are supplied with two (2) vent and combustion air-inlet termination restrictors. These restrictors help the water heater achieve peak efficiency when the water heater is installed using 3 in. (7.6 cm) diameter pipe at the minimum equivalent vent and combustion air-inlet lengths specified in Table 2.

**IMPORTANT: DO NOT** install the termination restrictors in equivalent vent and/or combustion air-inlet lengths longer than 8 ft. (2 m) or on any other Power Direct Vent model.

**NOTICE: Termination Restrictors supplied for use with 75 Gallon models ONLY.**

Terminals with 1/2 in. (1.3 cm) Mesh  
Protective Screens and Termination  
Restrictors Inside.  
Note: Termination Restrictors used on  
75 Gallon models ONLY

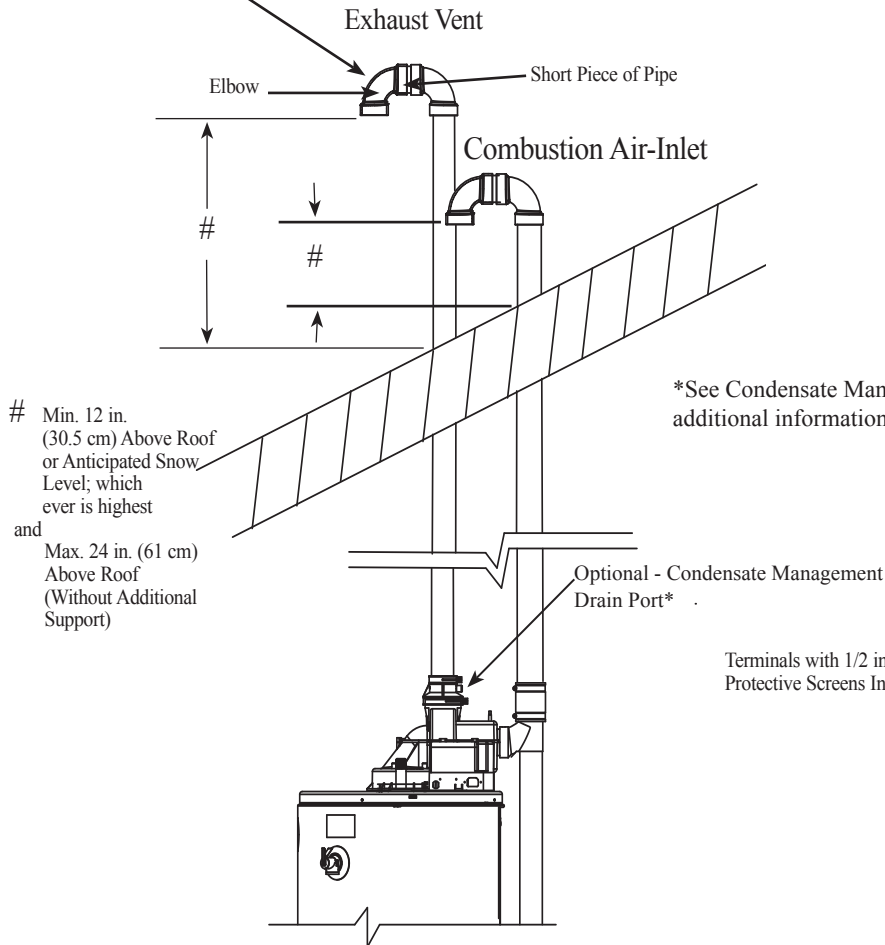

\*See Condensate Management Section for additional information about optional piping.

# Min. 12 in. (30.5 cm) Above Roof or Anticipated Snow Level; which ever is highest and  
# Max. 24 in. (61 cm) Above Roof (Without Additional Support)

**Exhaust Vent and /or Combustion Air-Inlet Pipe Through Roof**

**IMPORTANT: The vent terminal must not terminate below the combustion air-inlet terminal.**

\*See Condensate Management Section for additional information about optional piping.

Terminals with 1/2 in. (1.3 cm) Mesh  
Protective Screens Inside.

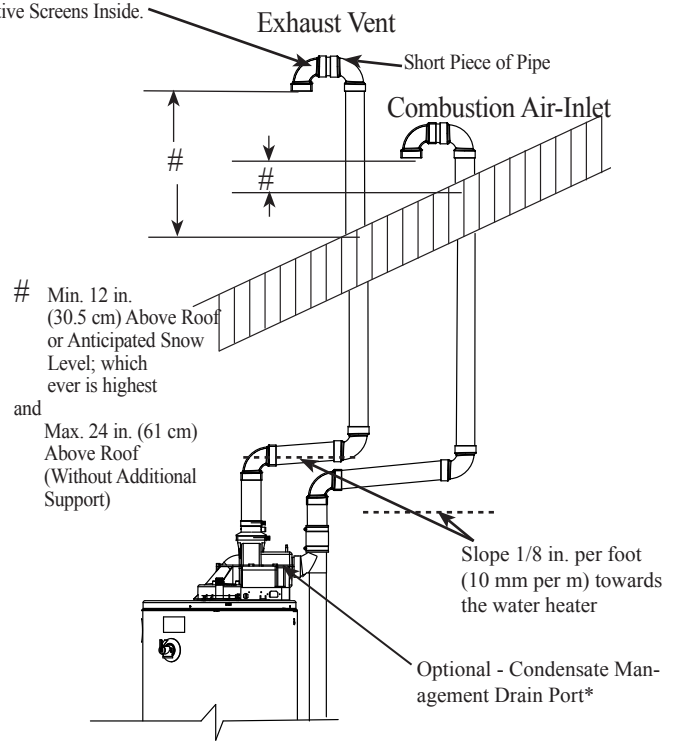

# Min. 12 in. (30.5 cm) Above Roof or Anticipated Snow Level; which ever is highest and  
# Max. 24 in. (61 cm) Above Roof (Without Additional Support)

Slope 1/8 in. per foot (10 mm per m) towards the water heater

**Alternate Vent and /or Combustion Air-Inlet Pipe Through Roof**

# Installing the Water Heater

---

**Vertical Vent - Alternate Concentric Terminal Installation:** *Contact Manufacturer's National Service Department for Kit information, see "If You Need Service" section.*

**NOTICE: All pipe, fittings, solvent cement, primers and procedures must conform to American National Standards Institute and American Society for Testing and Materials (ANSI/ASTM) standards.**

The location of the vent and combustion air-inlet terminal depends on the following minimum clearances and considerations.

- 1 Minimum 12 in. (30.5 cm) above roof.
- 2 Minimum 12 in. (30.5 cm) above anticipated snow level.
- 3 Maximum 24 in. (61 cm) above roof level without additional support for vent.
- 4 Four (4) ft. (1.22 m) from any gable, dormer or other roof structure with building interior access (i.e., vent, window, etc.).
- 5 Ten (10) ft. (3.05 m) from any forced air inlet to the building. Any fresh or make-up air inlet such as a dryer or furnace area is considered to be a forced air inlet.

Read these instructions thoroughly and make sure you understand all steps and procedures before proceeding with the installation.

Determine the location for the concentric terminal then make a 5 in. (12.7 cm) hole through the roof and interior ceiling(s) to accommodate the terminal, vent and combustion air-inlet system pipes and install a weather-seal boot/flashing (not supplied) for 4 -1/2 in. (12.4 cm) PVC pipe.

The concentric terminal assembly is designed to accept 3 in. (7.6 cm) diameter pipe. If 2 in. (5.1 cm) diameter pipe is used

- Then either 2 in. x 3 in. (5.1 cm x 7.6 cm) pipe increasers
- Or flush bushings must be installed to the vent and combustion air-inlet connections of the terminal assembly.
- **DO NOT** use the concentric terminal assembly with 4 in. (10.2 cm) vent and combustion air-inlet systems.

Disassemble the concentric terminal assembly.

- Note: The concentric terminal assembly consists of an inner, straight vent pipe, an outer, straight combustion air-inlet pipe, a Wye fitting and rain cap.

From inside the building, insert the outer, straight combustion air-inlet pipe through the weather-seal boot flashing so that the height from the roof to the rear of the rain cap when installed is as specified in the diagram.

**NOTICE: The concentric terminal assembly may be reduced in length as follows:**

- Measure for desired installation length then cut the outer, straight combustion air-inlet pipe accordingly but not less than 12 in. (30 cm).
- Measure and cut the straight inner vent pipe of the concentric terminal assembly so it is 13 in. (5.1 cm) longer in length than the outer, straight combustion air-inlet pipe.
- Ensure that there is no insulation or debris in the pipe.

Assemble the vent pipe assembly.

- Clean and cement the rain cap to the inner, straight vent pipe.

From the outside, slide the vent pipe with rain cap assembly through the combustion air-inlet pipe until the rain cap is fully seated on the pipe.

- Clean and cement the rain cap to the combustion air-inlet pipe.
- Clean and cement a 3 in. (7.6 cm) diameter, SDR 45, PVC, 90°, 1/4 standard bend elbow to the rain cap.
- Clean and cement a short, straight section of 3 in. (7.6 cm) diameter, straight pipe to the 90° street elbow.

- Clean and cement a 3 in. (7.6 cm) diameter, Schedule 40, PVC, 90°, 1/4 standard bend elbow to the short, straight section of pipe.

From the inside, clean and cement the Wye fitting to the vent and combustion air-inlet pipes of the termination assembly.

Complete the installation of the remainder of the vent system and attach it to the vent connector fitting on the water heater's blower assembly.

- Horizontal lengths of the vent system must slope towards the water heater a minimum of 1/8 in. per foot (10 mm per m).
- **DO NOT** use unequal diameters of pipe and fittings for the vent and combustion air-inlet systems except as defined previously.

**NOTICE:** The difference between the vent and combustion air-inlet system equivalent lengths must be no greater than 5 ft. (1.5 m).

Complete the installation of the remainder of the combustion air-inlet system and attach it to the combustion air-inlet connector fitting on the water heater's combustion air-inlet tube assembly.

Support vertical and horizontal lengths of the vent and combustion air-inlet systems as previously mentioned.

**IMPORTANT:** Ensure that all the coupling clamps are tight before allowing the water heater to operate.

**⚠ WARNING: DO NOT** operate the water heater with the rain cap and elbows removed or recirculation of combustion products may occur and/or the vent and combustion air-inlet systems could take in water, causing damage to the water heater. Failure to follow this warning could result in damage to the unit, improper operation, personal injury, or death.

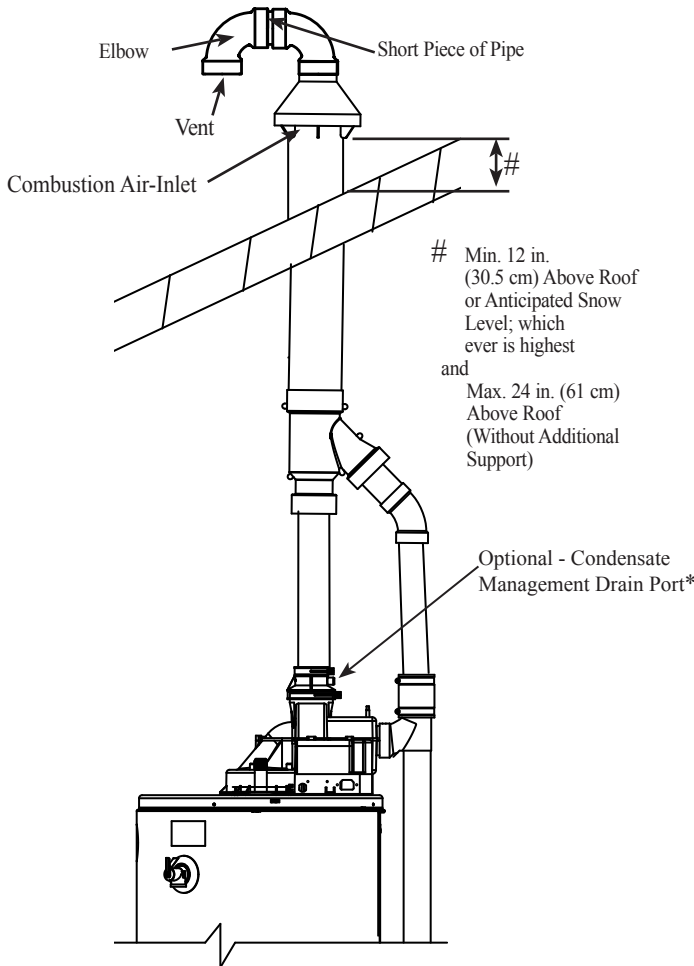

**Concentric Vent and /or Combustion Air-Inlet Pipe Through Roof**

\*See Condensate Management Section for additional information about optional piping.

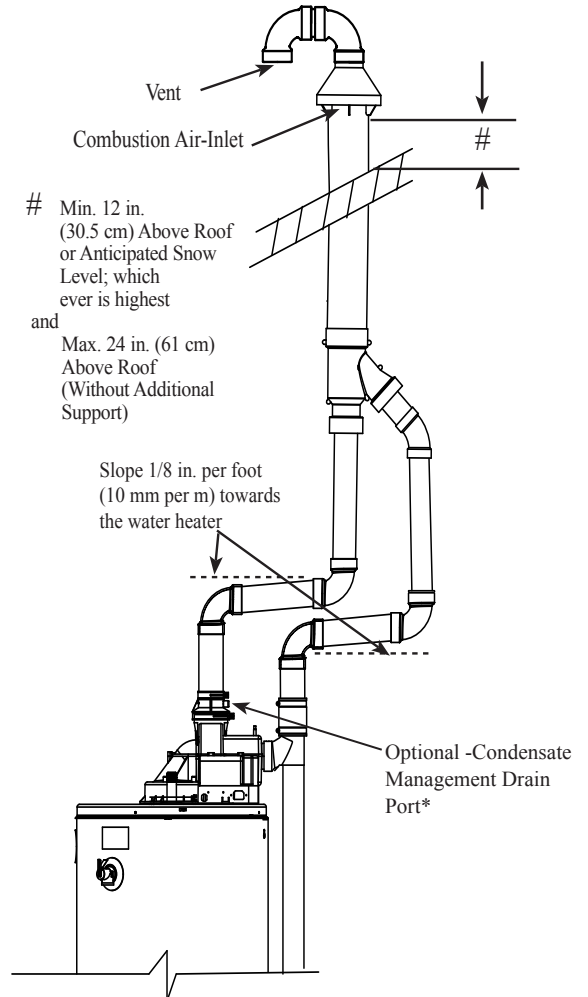

**Alternate Concentric Vent and /or Combustion Air-Inlet Pipe Through Roof**

# Installing the Water Heater

## Condensate Management - Optional Piping

There is no condensate collection and disposal required for Rheem water heaters under most conditions. Installations where the vent system length is short or where it runs through conditioned space in the home, such as basements or interior walls, **DO NOT** typically cause condensation and will not require any condensation disposal methods regardless of vent pipe slope. The image on page 20 shows the recommended vent pipe slope of no less than 1/8 in. per foot (10 mm per m) away from the water heater. Any condensation in the venting system will drain toward the vent termination. The blower pipe coupling features a capped drain port which is not needed in this case.

**▲ CAUTION:** Make sure the drain port cap is securely in place.

There are vent piping configurations, when combined with certain environmental conditions that can produce enough condensate to require collection and disposal. When a slope away from the water heater cannot be achieved and condensate handling is required in a horizontal vent system, slope the vent pipe toward the water heater 1/8 in. per foot (10 mm per m) minimum and condensate management means as follows:

- Remove the cap from vent pipe coupling, drain port on the blower assembly.

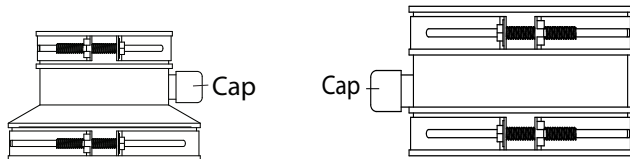

- Connect 1/2 in. I.D. flexible, PVC (or equivalent material), clear tubing to the drain port.  
**NOTICE:** The tubing must be of sufficient length to reach a floor drain, outside the building or other required condensate disposal termination requirements (Refer to local codes).
- Loop the drain tube so that it has a circular trap and secure the top and bottom of the loop with wire ties or plastic zip ties as shown. **DO NOT** restrict any portion of the drain tube. The loop and all sections of the tube must not be restricted or collapsed.
- Fill the drain tube with water so that no combustion gases might vent into the room.
- Route the drain tube to a floor drain or outside the building or refer to local codes for any condensation requirements..

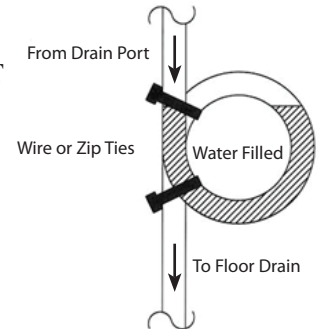

**▲WARNING: DANGER OF FIRE OR BODILY INJURY - Solvent cements and primers are highly flammable. Provide adequate ventilation and DO NOT assemble near heat source or open flame. DO NOT smoke. Avoid skin or eye contact. Observe all cautions and warnings on material containers.**

**▲CAUTION:**  
For proper installation: **DO NOT** use solvent cement that has become curdled, lumpy or thickened. **DO NOT** thin solvent cement. Observe shelf precautions printed on the containers. For applications below 32°F (0°C) use only low temperature type solvent cement. Appropriate solvent and cleaner must be used for the type of pipe used (PVC, CPVC or ABS).

## Cementing Joints

All joints in the vent piping must be properly sealed and the following materials are recommended:

PVC materials should use ASTM D2564 grade cement.

CPVC materials should use ASTM F493 grade cement.

ABS materials should use ASTM D2235 grade cement.

Cleaner-Primer and Medium Body Solvent Cement:

- 1 Cut pipe end square, remove jagged edges and burrs. Chamfer end of pipe, then clean fitting socket and pipe joint area of all dirt, grease or moisture.
- 2 After checking pipe and socket for proper fit, wipe socket and pipe with cleaner-primer. Apply a liberal coat of primer to inside surface of socket and outside of pipe. **DO NOT** allow primer to dry before applying cement.

- 3 Apply a thin coat of cement evenly in the socket. Quickly apply a heavy coat of cement to the pipe end and insert pipe into fitting with a slight twisting motion until it bottoms out.

**NOTICE: Cement must be fluid; if not, recoat.**

- 4 Hold the pipe fitting for 30 seconds to prevent the tapered socket from pushing the pipe out of the fitting.
- 5 Wipe all excess cement from the joint with a rag. Allow 15 minutes before handling. Cure time will vary according to fit, temperature and humidity.

**NOTICE: Stir the solvent cement frequently while using. Use a natural bristle brush or the dauber supplied with the can.**

**NOTICE: This unit is equipped with a Flammable Vapor Sensor. DO NOT apply power until enough time has passed to allow the vapors from the primer and cement to dissipate.**

# Wiring

If local codes permit, the water heater may be connected to electric service with the power cord provided (**DO NOT** use an extension cord). A grounding receptacle is required.

If local codes **DO NOT** permit the use of cord connections, a 120 V, 50/60 Hz power supply, with suitable disconnecting means, must be connected to the black and white leads in the blower assembly.

The water heater must be electrically grounded in accordance with local codes, or, in the absence of local codes, in accordance with latest edition of the National Electric Code ANSI/NFPA No. 70. Refer to the figures below for water heater internal wiring.

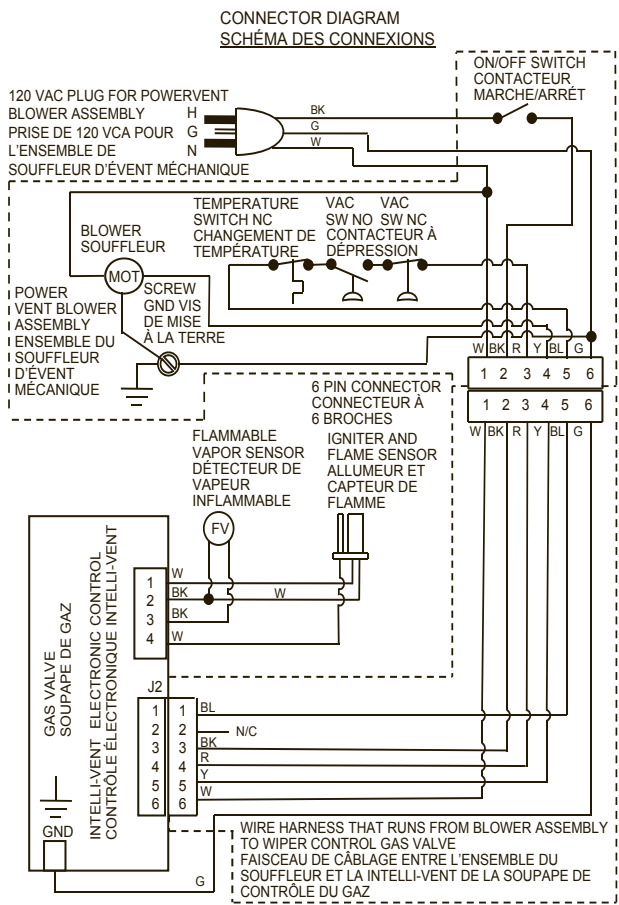

ANY REPLACEMENT IGNITOR CABLE MUST BE RATED AT 250° C  
TOUT CÂBLE D'ALLUMAGE DE REMPLACEMENT DOIT ÊTRE ÉTALONNÉ À 250° C

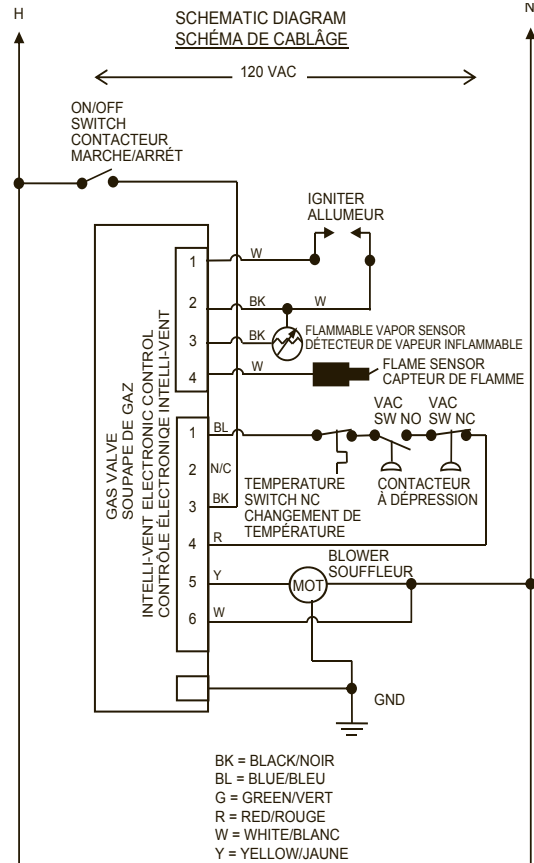

NOTE: IF ANY OF THE ORIGINAL WIRE SUPPLIED WITH THE APPLIANCE MUST BE REPLACED, IT MUST BE REPLACED WITH A 18 GA, 600 V, 105° C WIRE.  
REMARQUE: SI UNE PARTIE QUELCONQUE DU CÂBLAGE ORIGINAL FOURNI AVEC L'APPAREIL DOIT ÊTRE REMPLACÉE, ELLE DOIT ÊTRE REMPLACÉE AVEC UN FIL DE CALIBRE 18, 600 VCA, 105° C.

120V 50/60 Hz LESS THAN 5 AMPS

**⚠ CAUTION!** Label all wires prior to disconnection when servicing controls. Wiring errors can cause improper and dangerous operation. VERIFY PROPER OPERATION AFTER SERVICING!

# Installing the Water Heater

**▲WARNING:** If local codes require external application of insulation blanket kits the manufacturer's instructions included with the kit must be carefully followed.

## Insulation Blankets

Insulation blankets, available to the general public, for external use on gas water heaters are not necessary. The purpose of an insulation blanket is to reduce the standby heat loss encountered with storage tank heaters. This water heater meets or exceeds the National Appliance Energy Conservation Act standards with respect to insulation and standby loss requirements making an insulation blanket unnecessary.

The manufacturer's warranty does not cover any damage or defect caused by installation, attachment or use of any type of energy saving or other unapproved devices (other than those authorized by the manufacturer) into, onto or in conjunction with the water heater. The use of unauthorized energy saving devices may shorten the life of the water heater and may endanger life and property.

The manufacturer disclaims any responsibility for such loss or injury resulting from the use of such unauthorized devices.

**▲CAUTION:** If local codes require the application of an external insulation blanket to this water heater, pay careful attention to the following so as not to restrict the proper function and operation of the water heater:

- **DO NOT** cover the operating or warning labels attached to the water heater or attempt to relocate them on the exterior of insulation blanket.
- **DO NOT** apply insulation to the top of the water heater. This will interfere with the safe operation of the blower assembly.
- **DO NOT** cover the burner access door, jacket door, gas control (thermostat) or pressure and temperature relief valve.
- **DO NOT** apply insulation to the area where the Flammable Vapor Sensor is located. This area must be unobstructed so as not to restrict air flow to the sensor.
- Inspect the insulation blanket frequently making certain it has not sagged and it is not restricting the air flow to the Flammable Vapor sensor located around the lower perimeter of the water heater jacket. This could result in an unsafe operating condition.

## Hot and Cold Pipe Insulation Installation

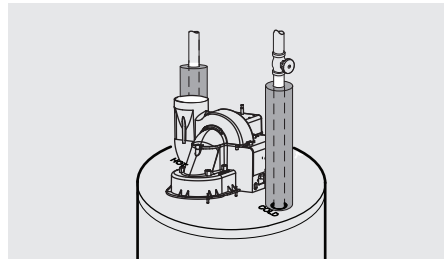

Typical vertical piping arrangement

For increased energy efficiency, some water heaters have been supplied with two 24 in. (61 cm) long sections of pipe insulation.

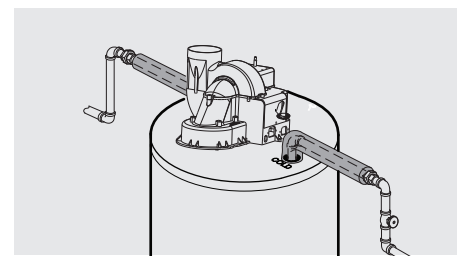

Typical horizontal piping arrangement (Piping for Top Cap NOT shown)

Please install the insulation, according to the illustrations above, that best meets your requirements.

## T&P Insulation Installation

For increased energy efficiency, this water heater has been supplied with a 2 3/8" section of T&P insulation. Please install the insulation as shown below.

Slip the insulation cover over the T&P Valve through the center hole and align the hole in the side with the opening of the T&P Valve.

Ensure the T&P Valve opening is not obstructed by the insulation.

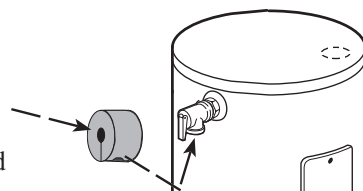

Typical Side Connect T & P Arrangement.

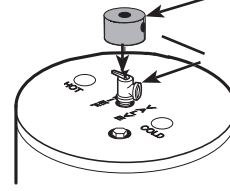

Typical Top Connect T & P Arrangement.

Slip the insulation cover over the T&P Valve through the center hole and align the hole in the side with the opening of the T&P Valve.

Ensure the T&P Valve opening is not obstructed by the insulation.

---

## Heat Traps

For increased energy efficiency, some water heaters have been supplied with factory installed 3/4 in. or 1 in. NPT heat trap fittings in the hot outlet line and cold water inlet line. These heat trap fittings may require a minimum of one (1) 90°, 3/4 in. or 1 in. NPT elbow and may require

an additional 90°, 3/4 in. or 1 in. NPT elbow or a 3/4 in. or 1 in. coupling depending on your model of water heater and installation needs. See illustration of nipples and heat traps on page 43.

---

## Top Cap Installation (For Certain Models Only)

Read these instructions thoroughly and make sure you understand all the steps and procedures before proceeding with the installation.

Carefully remove the Top Cap from the water heater carton. Install the water heater as specified per this Use & Care Manual. Note: Also see information as detailed in “Water Supply Connections” section.

Locate the small plastic bag containing the three (3) Dual Lock® strips and two (2) sheet metal screws to be used to attach the Top Cap in the Use & Care Manual bag. Peel off one side of the Dual Lock® strips and firmly press near the Top Cap mounting tabs and the inside center front of the rim on the Top Cap. See diagram for detail.

Peel off the other side of the Dual Lock® strips and place the Top Cap on the top front center of the water heater ensuring that it is aligned cor-

rectly and properly positioned on top of the water heater. Press firmly to ensure proper attachment is made.

Align holes in mounting tabs on the Top Cap with the holes in the top of the heater then secure the Top Cap to the water heater with the two (2) #8 sheet metal screws (supplied).

**IMPORTANT: DO NOT** over tighten the screws as this may damage the Top Cap.

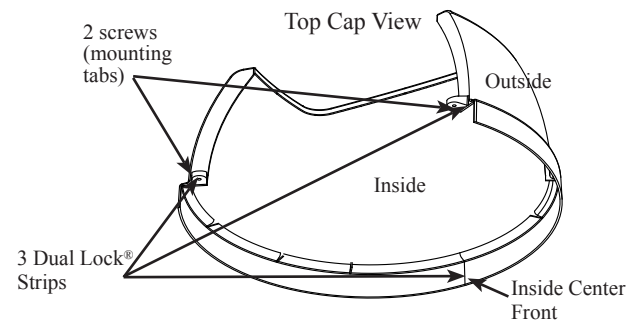

---

## During Installation of this water heater.....

### DO

- **DO** check inlet gas pressure to ensure that it is within the range specified on the rating plate.
- **DO** maintain proper clearances to combustibles as specified on the rating plate.
- **DO** allow enough time for joint cement vapors to dissipate BEFORE applying power to the water heater.
- **DO** ensure that the venting system complies with the guidelines found in the Use and Care Manual and National Fuel Gas Code.
- **DO** contact a qualified service technician if the main burner will not stay lit. The burner chamber is designed to be sealed utilizing a gasket and tamper resistant screws.

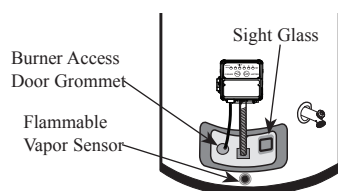

### DON'T

- **DON'T** block or restrict the Flammable Vapor Sensor located around the lower portion of the water heater jacket.
- **DON'T** remove the Burner Access Door unless absolutely necessary. This should only be done by a qualified service technician. A new burner access door gasket must be installed on any burner access door that has been removed.
- **DON'T** install this water heater where standing water may occur. The base of the water heater is meant to be mounted on a dry surface.
- **DON'T** allow cleaners, solvents, or other materials to come into contact with the Flammable Vapor Sensor.
- **DON'T** operate the water heater if the sight glass or burner access door grommet is damaged or broken.

# Installation Checklist

---

## A. Water Heater Location

- In a location where the vent and combustion air-inlet systems will be within the requirements specified in this manual.
- Indoors and protected from freezing temperatures.
- Proper clearance from combustible surfaces observed and water heater not installed on carpeted floor.
- Air supply free of corrosive elements and flammable vapors.
- Provisions made to protect area from water damage.
- Sufficient room to service the water heater.
- Combustible materials, such as clothing, cleaning materials, rags, etc. clear of the base of the water heater.
- Flammable vapor sensor is not blocked.

---

## B. Water Supply

- Water heater completely filled with water.
- Air purged from water heater and piping.
- Water connections tight and free of leaks.

---

## C. Gas Supply

- Gas line equipped with shut-off valve, union and sediment trap.
- Approved pipe joint compound used.
- Soap and water solution used to check all connections and fittings for possible gas leak.
- Gas Company inspected installation (if required).

---

## D. Relief Valve

- Temperature and Pressure Relief Valve properly installed and discharge line run to open drain.
- Discharge line protected from freezing.

---

## E. Venting and Combustion Air-Inlet Systems

- Water Heater vented separately from all other appliances.
- Blower assembly properly installed.
- Proper materials and techniques used in the installation of the vent and combustion air-inlet systems.
- Vent pipe properly secured to the exhaust connector of the blower assembly.
- Vent and combination air-inlet systems supported at required intervals.
- Appropriate minimum clearances observed.
- Precautions taken to prevent moisture damage around vent termination.
- Vapors from non-metallic pipe cement and primer have dissipated prior to applying electrical power.
- Combustion Air-Inlet pipe properly secured to the combustion air-inlet piping tee.

---

## F. Wiring

- Correct power supply (120 VAC).
- Electrical connections tight.
- Water Heater properly grounded and proper polarity observed.

# Supplemental Instructions for Gas Water Heaters Installed in Potable Water/Space Heating Applications

Local codes or plumbing authority requirements may vary from the instructions or diagrams provided in this manual and take precedent over these instructions.

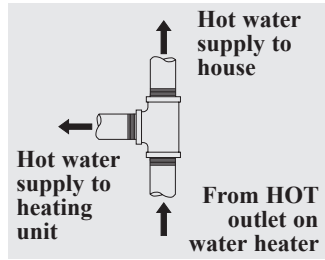

Tee fitting for vertical hot water supply lines.

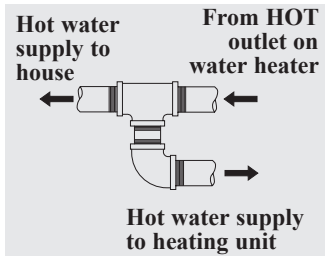

Tee fitting for horizontal hot water supply lines.

## Combination Potable Water and Space Heating Application

Tee fitting must be installed as shown. This ensures that any air in the water lines will be purged through the domestic water faucets and showers.

**⚠ DANGER:** When this system requires water for space heating at elevated temperatures (above 125°F [52°C.]), a mixing or tempering valve must be installed in the hot water supply line to the house in order to reduce the scald hazard potential.

**⚠ DANGER:** Any piping or components used in the installation of this water heater in a combination potable and space heating application must be suitable for use with drinking water.

**⚠ DANGER:** If this water heater is installed in an application intended to supply domestic hot water needs and hot water for space heating purposes, DO NOT connect the heater to an existing heating unit or components of a heating system that have previously been used with a non drinking water system. Toxic chemicals such as those used for boiler treatment may be present and will contaminate the drinking water supply causing possible health risks. Never introduce toxic chemicals, such as those used for boiler treatment, into this system.

**NOTICE:** 50 ft. (15.2 m) maximum distance from water heater to fan coil (developed length) is required for Massachusetts State.

## Typical Piping Diagram for Combination Potable/Space Heating Installation

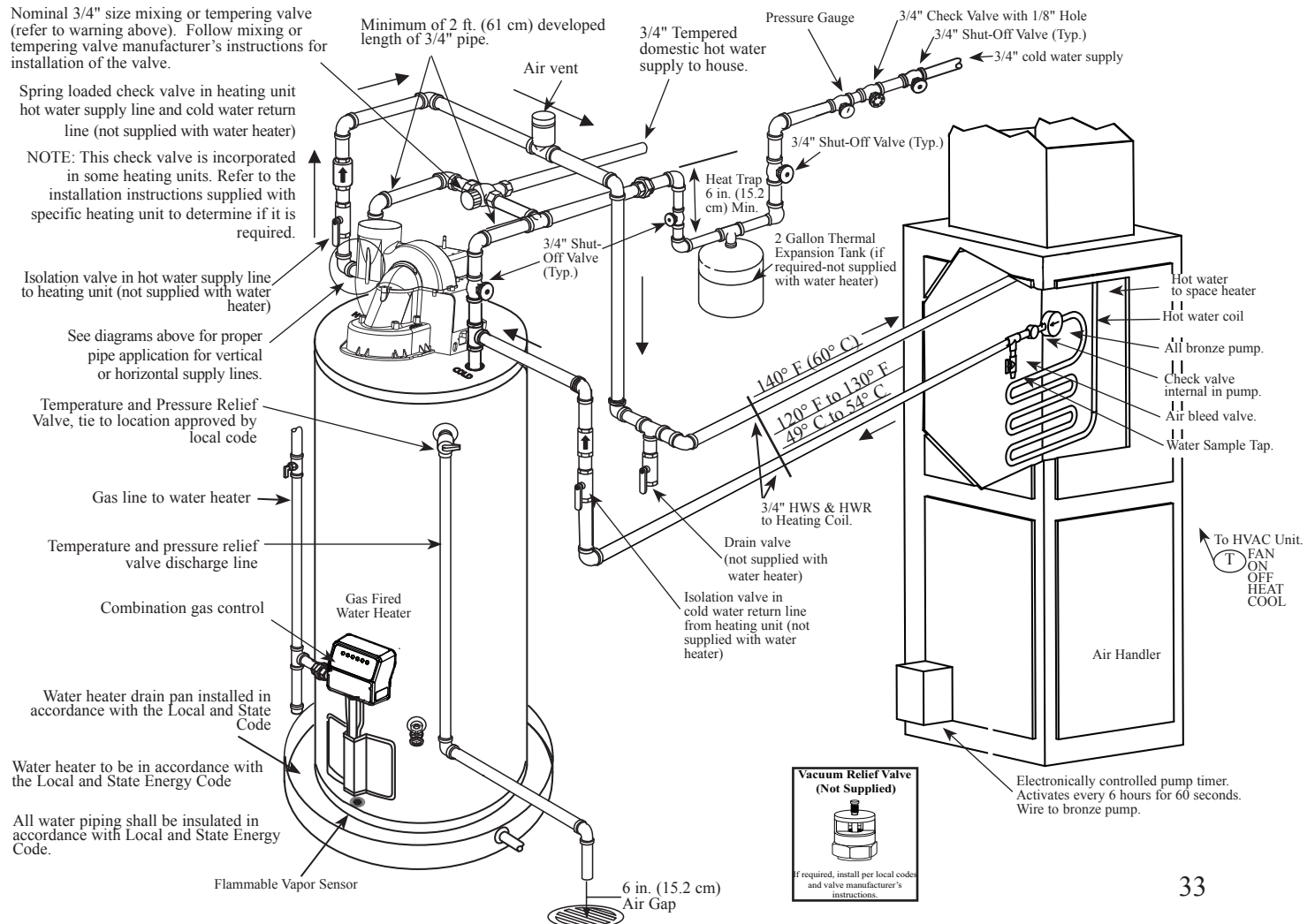

# Lighting the Water Heater

Before operating this water heater, be sure to read and follow the instructions on the label pictured below and all other labels on the water heater, as well as the warnings printed in this manual. Failure to do so can result in unsafe operation of the water heater resulting in property damage, personal injury, or death. Should you have any problems reading or following the instructions in this manual, STOP, and get help from a qualified person.

## FOR YOUR SAFETY READ BEFORE OPERATING

**⚠ WARNING:** If you do not follow these instructions and the Use & Care Manual instructions exactly, a fire or explosion may result causing property damage, personal injury or loss of life.

- A. This appliance does not have a pilot. It is equipped with an ignition device which automatically lights the burner. Do **NOT** try to light the burner by hand.
- B. BEFORE PUTTING THIS APPLIANCE INTO SERVICE - Smell all around the appliance area for gas. Be sure to smell next to the floor because some gas is heavier than air and will settle on the floor.
- WHAT TO DO IF YOU SMELL GAS**
- Do not try to light any appliance.
  - Do not touch any electric switch; do not use any phone in your building.
  - Immediately call your gas supplier from a neighbor's phone. Follow the gas supplier's instructions.
- C. Use only your hand to push in the gas control buttons. Never use tools. If the control buttons will not push in, don't try to repair them, call a qualified service technician. Force or attempted repair may result in fire or explosion.
- D. Do not use this appliance if any part has been under water. Immediately call a qualified installer or service agency to replace a flooded water heater. Do not attempt to repair the unit! It must be replaced!

## OPERATING INSTRUCTIONS

1. Stop! Read the safety information above on this label.
2. Toggle the "ON/OFF" switch located on the blower assembly to the "ON" position.
3. Set the thermostat to the lowest setting by pressing the COOLER ⏪ and HOTTER ⏩ buttons at the same time and holding them for (1) second. Depress the COOLER ⏪ button until only the WARM indicator light is lit.
4. Toggle the "ON/OFF" switch located on the blower assembly to the "OFF" position.
5. Turn off all electrical power to the appliance.
6. This appliance is equipped with a Hot Surface Ignition System which automatically lights the burner. Do **NOT** open the inner door of this appliance and try to light the burner by hand!
7. Wait five (5) minutes to clear out any gas. If you smell gas, STOP! Follow "B" in the safety information above on this label. If you do not smell gas, go ahead to the next step.
8. Turn on all electrical power to the appliance.
9. Toggle the "ON/OFF" switch located on the blower assembly to the "ON" position.
10. Set thermostat to the desired temperature setting by pressing the COOLER ⏪ and HOTTER ⏩ buttons at the same time and holding them for (1) second. Depress the HOTTER ⏩ button until the desired temperature display setting is lit. The preferred starting point for temperature setting is indicated by ▽ on the thermostat.
11. If the appliance will not operate, follow the instructions "TO TURN OFF GAS TO APPLIANCE" and call your service technician or gas supplier.

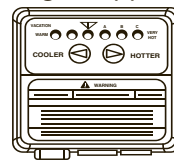

## TO TURN GAS OFF TO THE APPLIANCE

1. Set the thermostat to the lowest setting by first depressing the COOLER ⏪ and HOTTER ⏩ buttons at the same time and holding for (1) second. Depress the COOLER ⏪ button until only the WARM indicator light is lit.
2. Toggle the "ON/OFF" switch located on the blower assembly to the "OFF" position.
3. Turn off all electrical power to the appliance.

# Operating the water heater

---

**▲ CAUTION:** Hydrogen gas can be produced in a hot water system served by this water heater that has not been used for a long period of time (generally two weeks or more). **HYDROGEN GAS IS EXTREMELY FLAMMABLE!!** To dissipate such gas and to reduce risk of injury, it is recommended that the hot water faucet be opened for several minutes at the kitchen sink before using any electrical appliance connected to the hot water system. If hydrogen is present, there will be an unusual sound such as air escaping through the pipe as the water begins to flow. **DO NOT** smoke or use an open flame near the faucet at the time it is open.

## Safety Precautions

- A** **DO** turn off manual gas shut-off valve if water heater has been subjected to over heating, fire, flood, physical damage or if the gas supply fails to shut off.
  - B** **DO NOT** turn on water heater unless it is completely filled with water.
  - C** **DO NOT** turn on water heater if cold water supply shut-off valve is closed.
  - D** **DO NOT** allow combustible materials such as newspaper, rags or mops to accumulate near water heater.
  - E** **DO NOT** store or use gasoline or other flammable vapors and liquids, such as adhesives or paint thinner, in vicinity of this or any other appliance. If such flammables must be used, open doors and windows for ventilation, and all gas burning appliances in the vicinity should be shut off including their pilot burners, to avoid vapors lighting.
- NOTICE: Flammable vapors can be drawn by air currents from surrounding areas to the water heater.**
- F** If there is any difficulty in understanding or following the Operating Instructions or the Care and Cleaning section, it is recommended that a qualified person or serviceman perform the work.

---

## Operating Procedure

This water heater is equipped with a hot surface ignitor to light the main burner. There is no pilot light to be lit, but on initial start-up, it is recommended that the outer door be removed (leave inner door in place for safety) to view through the sight glass if the hot surface ignitor and main burner are operating properly.

Once filled with water, it is only necessary to plug the power cord in and make sure the “ON/OFF” switch located on the blower assembly is in the “ON” position to put the water heater into operation. Within seconds the hot surface ignitor should heat

up, then the gas valve should open and the main burner ignite. After the main burner ignites, replace the outer door. If no main burner flame is established, the combination gas control will go through three trials for ignition before going into a lock-out. A warning light will alert the user of this lock-out condition. If this happens, refer to “Troubleshooting Guide.”

**TO SHUT OFF WATER HEATER** – Turn switch located on the side of the blower assembly to the “OFF” position. See diagram on page 43 for location of blower assembly.

---

## Water Temperature Setting

The temperature of the water in the water heater can be regulated by pressing the buttons on the front of the combination gas control (thermostat).

Safety and energy conservation are factors to be considered when selecting the water temperature setting of the water heater’s combination gas control (thermostat). The lower the temperature setting, the greater the savings in energy and operating costs.

To comply with safety regulations, the combination gas control (thermostat) was set at its lowest setting before the water heater was shipped from the factory. The recommended starting point temperature is 120°F (49°C).

Water temperatures above 125°F (52°C) can cause severe burns or death from scalding. Be sure to read and follow the warnings outlined in this manual and on the label located on the water heater near the combination gas control (thermostat).

Mixing valves are available for reducing point of use water temperature by mixing hot and cold water in branch water lines. Contact a licensed plumber or the local plumbing authority for further information.

The chart on the next page may be used as a guide in determining the appropriate water temperature for your home.

**▲ DANGER: Hotter water increases the Potential for Hot Water SCALDS. Households with small children, disabled, or elderly persons may require a 120°F (49°C) or lower combination gas control (thermostat) setting to prevent contact with unsafe water temperatures.**

# Operating the Water Heater

## Water Temperature Setting...

Maximum water temperatures occur just after the burner has shut off. To determine the water temperature, turn on a hot water faucet and place a thermometer in the water stream.

To avoid any unintentional changes in water temperature settings, the combination gas control (thermostat) has a tamper resistant feature for changing the temperature setting. To change the temperature setting follow these instructions.

1. "Wake Up" the temperature indicators by holding down both "COOLER" and "HOTTER" temperature adjustment buttons at the same time for one second, see Figure below. One or two of the temperature indicators will light up. These indicators will only remain on for 30 seconds if no further buttons are pressed. After 30 seconds the control will go back to "sleep" mode.
2. Release both of the temperature buttons.
  - a. To decrease the temperature press and release the "COOLER" button until the desired setting is reached.
  - b. To increase the temperature press and release the "HOTTER" button until the desired setting is reached.

**NOTICE: Holding down the button will not continue to lower or raise the temperature setting. The button must be pressed and released for each temperature change desired.**

A condition known as "stacking" or "layering" can occur when a series of short and frequent hot water draws are taken.

The hottest temperature water will be at the top of the tank, closest to the outlet pipe delivering hot water to the home.

Stacking can cause this top layer of water to be hotter than the water toward the bottom of the tank near the combination gas control (thermostat). Therefore, always remember to test the water temperature with your hand before use and remember that hotter water increases the risk of scald injury.

Also, always supervise young children or others who are incapacitated.

The combination gas control (thermostat) is constructed with a built in safety shutoff device designed to shut off the gas supply to the burner if the main burner is extinguished for any reason.

The combination gas control (thermostat) is also equipped with a single use gas shut off device that will shut off the gas supply to the burner if the water heater exceeds normal operating temperatures. Refer to the Before You Call For Service section of this manual, or contact your dealer.

**▲ WARNING: Should overheating occur or the gas supply fail to shut off, turn off the manual gas (shutoff) valve to the appliance.**

If the water heater has been subjected to fire, flood or physical damage, turn off the manual gas (shutoff) valve, and **DO NOT** operate the water heater again until it has been checked by a qualified service technician.

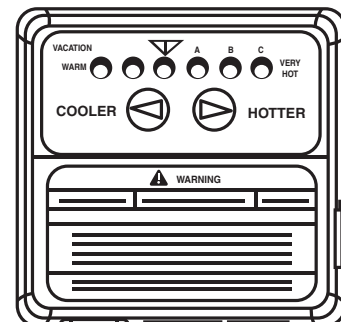

## Time/Temperature Relationship in Scalds

Water Temperature	Time To Produce a Serious Burn
120°F (49°C)	More than 5 minutes
125°F (52°C)	1½ to 2 minutes
130°F (54°C)	About 30 seconds
135°F (57°C)	About 10 seconds
140°F (60°C)	Less than 5 seconds
145°F (63°C)	Less than 3 seconds
150°F (66°C)	About 1½ seconds
155°F (68°C)	About 1 second

Table courtesy of Shriners Burn Institute

Temperature Setting	Display	Burns on Adult Skin
WARM = approx. 70°F (21°C)	▼ A B C	-----
▼ = approx. 120°F (49°C)	● ○ ○ ○ ○ ○	More than 5 minutes
A = approx. 130°F (54°C)	○ ○ ● ○ ○ ○	About 30 seconds
B = approx. 140°F (60°C)	○ ○ ○ ○ ● ○	Less than 5 seconds
C = approx. 150°F (66°C)	○ ○ ○ ○ ○ ●	About 1-1/2 seconds
C-Flashing = approx. 160°F (71°C)	○ ○ ○ ○ ○ ●	About 1/2 seconds

---

## Sequence of Operation

During initial start-up or a call for heat, the control will verify the vacuum switch is open.

Once the control verifies the vent pressure switch is open, the control will energize the blower motor for the pre-purge sequence (approximately 5 seconds).

The control will verify that the vent pressure switch has closed, ensuring that the blower is functioning properly and that the venting system is not blocked.

The control will then proceed through a sequence of self-diagnostics before initiating a trial for ignition.

During the trial for ignition, the hot surface ignitor will warm up.

Once the hot surface ignitor warms up, the main gas valve will open allowing gas to flow to the main burner.

Once the main burner ignites, the control will verify that the burner flame is present through the flame sense circuit. The hot surface ignitor will then turn off.

The main burner will remain lit throughout the heat cycle until the water temperature setting is reached.

Once the water temperature setting is reached, the control will close the main gas valve which will extinguish the main burner flames.

The blower motor will stay energized for an additional 5 seconds after the control verifies that the burner flame is extinguished in order to clear combustion gases from the water heater.

After the post-purge sequence, the control will de-energize the blower motor and go into a stand-by mode awaiting the next call for heat.

This water heater is equipped with a flammable vapor sensor that is monitored continuously by the electronic control in all modes of operation.

In the event that flammable vapors are detected, the control will automatically shut down the water heater and prevent the water heater from being started again.

The following is a list of materials that will cause the Flammable Vapor Sensor to shut down the water heater.

- Vapors of Gasoline.
- Vapors of certain flammable paints, stains, and thinners.
- Vapors of vent pipe Cement & Solvents.
- Bleach (direct contact with flammable vapor sensor).
- Some other flammable materials and their vapors.

If the flammable vapor sensor shuts down the water heater, then the electronic control will display the appropriate error code and you should then promptly contact a qualified service technician.

Refer to the “**NOTICE**” on page 3 for additional information.

# Care and Cleaning of the Water Heater

## Draining the Water Heater

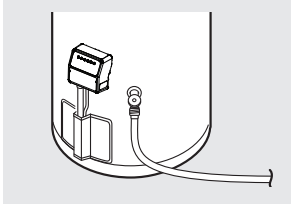

**▲CAUTION:** Shut off gas to the water heater at the manual gas shut-off valve before draining water.

**▲DANGER:** Before manually operating the temperature and pressure relief valve, make certain no one will be exposed to the hot water released by the valve. The water drained from the tank may be hot enough to present a scald hazard and should be directed to a suitable drain to prevent injury or damage.

Before turning off the cold water supply to the water heater, open a hot water faucet allowing sufficient cold water into the tank to prevent the risk of a scald injury while draining the water heater. Once the water in the tank is no longer hot, turn off the cold water supply to the water heater. Open a hot water faucet or lift the handle on the relief valve to admit air to the tank.

Attach a garden hose to the drain valve on the water heater and direct the stream of water to a drain. Open the valve.

**▲DANGER:** Before manually operating the relief valve, make certain no one will be exposed to the danger of the hot water released by the valve. The water may be hot enough to create a scald hazard. The water should be released into a suitable drain to prevent injury or property damage.

**▲DANGER:** Hotter water increases the potential for Hot Water Scalds.

**▲DANGER:** Failure to perform the recommended Routine Preventative Maintenance can harm the proper operation of this water heater, which can cause carbon monoxide dangers, excessive hot water temperatures and other potentially hazardous conditions.

## Routine Preventative Maintenance

Properly maintained, your water heater will provide years of dependable trouble-free service.

It is recommended that a periodic inspection of the combination gas control (thermostat), burner, relief valve, internal flue-way, vent and combustion air-inlet systems be made by service personnel qualified in gas appliance repair.

It is suggested that a routine preventative maintenance program be established and followed by the user.

Inspect the combustion air-inlet and vent systems. Make certain that all joints are secure and that combustion air-inlet and vent pipe supports are all in place. Check the outdoor combustion air-inlet and vent terminals to see that they are free of obstructions, and that there is no damage nearby caused by condensate.

Periodically, lift and release the lever handle on the temperature pressure relief valve, located near the top of the water heater, to make certain the valve operates freely. Allow several gallons to flush through the discharge line to an open drain.

**NOTICE:** If the temperature and pressure relief valve on the water heater discharges periodically, this may be due to thermal expansion in a closed water system. Contact the water supplier or your plumbing contractor on how to correct this.

**DO NOT** plug the relief valve outlet.

A water heater's tank can act as a settling basin for solids suspended in the water. It is therefore not uncommon for hard water

deposits to accumulate in the bottom of the tank. If allowed to accumulate, these solids can cover the combination gas control (thermostat) sensors, causing the sensors to operate erratically. Because accumulated solids can prevent the combination gas control (thermostat) sensors from accurately reading the water temperature, the water at the fixture can be hotter than the combination gas control (thermostat) setting. It is suggested that a few quarts of water be drained from the water heater's tank every month to clean the tank of these deposits.

Rapid closing of faucets or solenoid valves in automatic water using appliances can cause a banging noise heard in a water pipe. Strategically located risers in the water pipe system or water hammer arresting devices can be used to minimize the problem.

The anode rod should be removed from the water heater's tank periodically, for inspection and replaced when more than 6 in. (15.2 cm) of core wire is exposed at either end of the rod.

Make sure the cold water supply is turned off before removing anode rod.

This water heater incorporates a combustion shut off device that shuts the operation of the water heater down if undesirable combustion conditions occur, such as the presence of flammable vapors or blockage of the combustion air-inlet and/or vent systems. Please contact a qualified service technician if this occurs.

---

**▲ DANGER: Combustible materials, such as clothing, cleaning materials, or flammable liquids, etc., must not be placed against or next to the water heater.**

## Housekeeping

Make sure the Flammable Vapor Sensor is not blocked or obstructed.

**DO NOT** expose the Flammable Vapor Sensor to water, solvents or cleaning agents.

---

## Combustion Air-Inlet and Vent System Inspection

Inspect the combustion air-inlet and vent systems. Make certain that all joints are secure and that combustion air-inlet and vent system supports are all in place. Check the outdoor combustion air-inlet and vent system terminals to see that they are free of

obstructions, and that there is no damage nearby caused by condensate.

---

## Burner Inspection

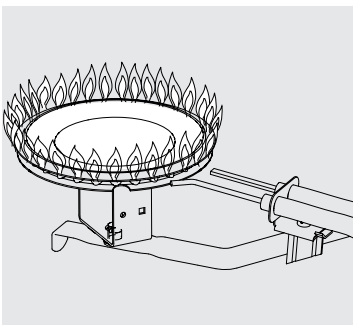

Representative burner flame pattern

Visually inspect the hot surface ignitor and main burner periodically.

Through the sight glass, inspect the hot surface ignitor with the main burner off and inspect the main burner while firing.

If any unusual burner operation is noted, the water heater should be shut off until qualified service assistance can be obtained.

**▲ CAUTION: For your safety, cleaning of the burner must be performed only by qualified service personnel, as it involves the disconnection of gas piping and leak testing. The burner chamber is a sealed area. If the burner access door is removed, the burner access door gasket must be replaced.**

For cleaning, remove the burner from the water heater. A vacuum cleaner can be used on the burner and floor shield inside the water heater. The burner can also be cleaned by scrubbing with mild detergent.

---

## Vacation and Extended Shut-Down

**NOTICE: Refer to the Hydrogen Gas Caution in the Operating Instructions.**

If the water heater is to remain idle for an extended period of time, the power and water to the appliance should be turned off to conserve energy and prevent a build-up of dangerous hydrogen gas.

The water heater and piping should be drained if they might be subjected to freezing temperatures.

After a long shut-down period, the water heater's operation and controls should be checked by qualified service personnel. Make certain the water heater is completely filled again before placing it in operation.

---

**NOTICE: DO NOT remove the anode rod from the water heater's tank, except for inspection and/or replacement, as operation with the anode rod removed will greatly shorten the life of the glass lined tank and will exclude warranty coverage.**

## Anode Rod

This water heater is equipped with an anode rod designed to prolong the life of the glass lined tank. The anode rod is slowly consumed, thereby eliminating or minimizing corrosion of the glass lined tank.

Water sometimes contains a high sulfate and/or mineral content and together with cathodic protection process can produce a hydrogen sulfide, or rotten egg odor in the heated water. Chlorination of the water supply should minimize the problem.

# Before You Call for Service



## Troubleshooting Tips

**Save time and money! Review the charts on the following pages first and you may not need to call for service.**

This water heater incorporates shut off devices that shuts the operation of the water heater down if undesirable combustion conditions occur, such as the presence of flammable vapors or blockage of the vent and/or combustion air-inlet systems. Please contact a Qualified Service Technician if this occurs.

Problem	Possible Causes	What To Do
Condensation	This usually happens when a new heater is filled for the first time.	This is normal, after the water in the tank warms up, the condensation will disappear. Refer to page 10 for more information.
	Moisture from the products of combustion condensing on the tank surface.	This is normal and will disappear in time. Refer to page 10 for more information.
	An undersized water heater will cause condensation.	Use a water heater size that meets the requirements of your needs.
Yellow flame or soot	Scale on top of the burner.	Contact a qualified service technician to remove scale.
	Vent and/or combustion air-inlet systems are blocked.	Remove obstruction or debris from vent and/or combustion air-inlet systems.
Unable to light the main burner	Air in gas line.	Contact a qualified service technician to purge the air from the gas line.
	Blocked vent system.	Contact a qualified service technician to evaluate vent system for blockage.
	Blocked combustion air-inlet system.	Contact a qualified service technician to evaluate the combustion air-inlet system for blockage.
	Pressure switches.	Make sure the pressure switch hoses are not "kinked".
	Wire connection(s) not fully secured.	Contact a qualified service technician to confirm wire connections.
	Combustion shutoff device tripped.	Combustion Shutoff Device(s) should be inspected by a qualified service technician.
	Gas control problem.	Contact a qualified service technician.
Main burner does not stay lit	Energy shutoff device open.	The combination gas control (thermostat) should be replaced by a qualified service technician.
	Combustion shutoff device tripped.	The combustion shutoff device should be inspected by a qualified service technician.

**⚠ CAUTION:** Label all wires prior to disconnection when servicing controls. Wiring errors can cause improper and dangerous operation. **VERIFY PROPER OPERATION AFTER SERVICING.**

**⚠ CAUTION:** For your safety **DO NOT** attempt repair of gas piping, combination gas control (thermostat), burners, vent and/or combustion air-inlet systems or other safety devices. Refer repairs to qualified service personnel.

# Before You Call For Service

## Troubleshooting Tips



Save time and money! Review the charts on the following pages first and you may not need to call for service.















This water heater incorporates shut off devices that shut the operation of the water heater down if undesirable combustion conditions occur, such as the presence of flammable vapors or blockage of the vent and /or combustion air-inlet systems. Please contact a Qualified Service Technician if this occurs.

Problem	Possible Causes	What to Do
Rumbling noise	Scale and sediment.	Drain the water heater to remove scale and sediment from the tank. Refer to page 38.
Relief valve producing popping noise or draining	Pressure build up caused by thermal expansion in a closed system.	This is an unacceptable condition and must be corrected. Contact the water supplier or plumbing contractor on how to correct this. <b>DO NOT</b> plug the relief valve outlet.
Not enough or no hot water	Water usage may have exceeded the capacity of the water heater.	Wait for the water heater to recover after an abnormal demand.
	Low gas pressure.	Check gas supply pressure and manifold pressure.
	The combination gas control (thermostat) may be set too low.	See the "Water Temperature Setting" of the water heater section of this manual.
	Leaking or open hot water faucets.	Make sure all faucets are closed.
	Check valve error codes.	Refer to gas valve error code table on page 42.
	"ON / OFF" switch turned off.	Turn "ON".
	Blower unplugged.	Plug in. verify power supply (120 VAC).
Water is too hot	Combustion Shutoff Device tripped.	Contact a qualified service technician.
	The combination gas control (thermostat) is set too high.	See the "Water Temperature Setting" of the water heater section of this manual.
	Combination gas control (thermostat) is defective.	Contact a qualified service technician to replace the combination gas control (thermostat).

**⚠ CAUTION:** Label all wires prior to disconnection when servicing controls. Wiring errors can cause improper and dangerous operation. **VERIFY PROPER OPERATION AFTER SERVICING.**

**⚠ CAUTION:** For your safety **DO NOT** attempt repair of gas piping, combination gas control (thermostat), burners, vent and or combustion air-inlet systems or other safety devices. Refer repairs to qualified service personnel.

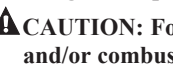
# Gas Valve LED Codes

LED Status	Problem	Solution
	An open earth ground circuit to the ignition system.	<ol style="list-style-type: none"> <li>1. Check that the earth ground connection is properly connected.</li> <li>2. Check that the ground conductor on the water heater is properly connected.</li> </ol>
	Wiring error or a high resistance to earth ground.	<ol style="list-style-type: none"> <li>1. Check proper connection of line neutral and hot wires.</li> <li>2. Check that the water heater is securely connected to earth ground.</li> </ol>
	Pressure switch remained closed longer than 5 seconds after the call for heat began.	<ol style="list-style-type: none"> <li>1. Verify that the wiring to the pressure switch(es) is correct.</li> <li>2. Replace the pressure switch(es).</li> </ol>
	Pressure switch remained opened longer than 5 seconds after the combustion blower was energized.	<ol style="list-style-type: none"> <li>1. Verify that the wiring to the pressure switch(es) is correct.</li> <li>2. Verify that the wiring to the pressure switch(es) is connected correctly.</li> <li>3. Check the vent and / or combustion air-inlet systems for obstructions.</li> </ol>
	Error in the hot surface ignitor circuit.	<ol style="list-style-type: none"> <li>1. Check that all wiring is correct and secure.</li> <li>2. Replace hot surface ignitor.</li> </ol>
	System in lockout.	<ol style="list-style-type: none"> <li>1. Gas supply is off or too low to operate. Turn on the gas supply and / or increase the inlet gas supply pressure.</li> <li>2. Hot surface ignitor not positioned correctly.</li> <li>3. Low voltage to the water heater. Increase supply voltage to rated voltage.</li> <li>4. Electric polarity to unit is incorrect - test and correct.</li> <li>5. Check the vent and /or combustion air-inlet systems for obstructions.</li> </ol>
	Problem in the combination gas valve driver circuit.	<ol style="list-style-type: none"> <li>1. Turn power to the water heater off for 10 seconds and then back on.</li> <li>2. Replace the combination gas control (thermostat).</li> </ol>
	Problem with the internal circuit.	<ol style="list-style-type: none"> <li>1. Turn power to the water heater off for 10 seconds and then back on.</li> <li>2. Replace the combination gas control (thermostat).</li> </ol>
	Problem with the internal circuit.	<ol style="list-style-type: none"> <li>1. Turn power to the water heater off for 10 seconds and then back on.</li> <li>2. Replace the combination gas control (thermostat).</li> </ol>
	Flame signal sensed out of proper sequence.	<ol style="list-style-type: none"> <li>1. Replace the combination gas control. (thermostat)</li> </ol>
	ECO activated.	<ol style="list-style-type: none"> <li>1. Replace the combination gas control (thermostat).</li> </ol>
	One of the temperature adjust buttons stuck closed.	<ol style="list-style-type: none"> <li>1. Press and release each of the buttons once.</li> <li>2. Replace the combination gas control (thermostat).</li> </ol>
	Water temperature sensor is either open or short circuited.	<ol style="list-style-type: none"> <li>1. Check that all wiring is correct and secure.</li> <li>2. Replace the combination gas control (thermostat).</li> </ol>
	Unit shuts down.	<ol style="list-style-type: none"> <li>1. Check for correct wiring to FV sensor.</li> <li>2. Check for open circuits to FV sensor.</li> <li>3. Replace FV sensor.</li> </ol>
	Unit shuts down and in lockout.	<ol style="list-style-type: none"> <li>1. FV sensor detected presence of flammable vapors.</li> <li>2. Contact a service agency.</li> </ol>

**⚠ CAUTION:** Label all wires prior to disconnection when servicing controls. Wiring errors can cause improper and dangerous operation. VERIFY PROPER OPERATION AFTER SERVICING.

**⚠ CAUTION:** For your safety DO NOT attempt repair of gas piping, combination gas control thermostat, burners, vent and/or combustion air-inlet systems or other safety devices. Refer repairs to qualified service personnel.

# Replacement Parts

For 40, 50, 65, and 75 Gallon Models equipped for use with Natural or Liquefied Petroleum/LP gas.

## Instructions For Placing a Parts Order

All parts orders should include:

- 1 The model and serial number of the water heater from the rating plate.
- 2 Specify type of gas (Natural or Liquefied Petroleum/LP gas) as marked on the rating plate.
- 3 Part description (as noted below) and number of parts desired.
- 4 Refer to page 44.

**CAUTION:** For your safety, **DO NOT** attempt repair of gas piping, gas control (thermostat), burners, vent connectors or other safety devices. Refer repairs to qualified service personnel.

Use only original equipment replacement parts.

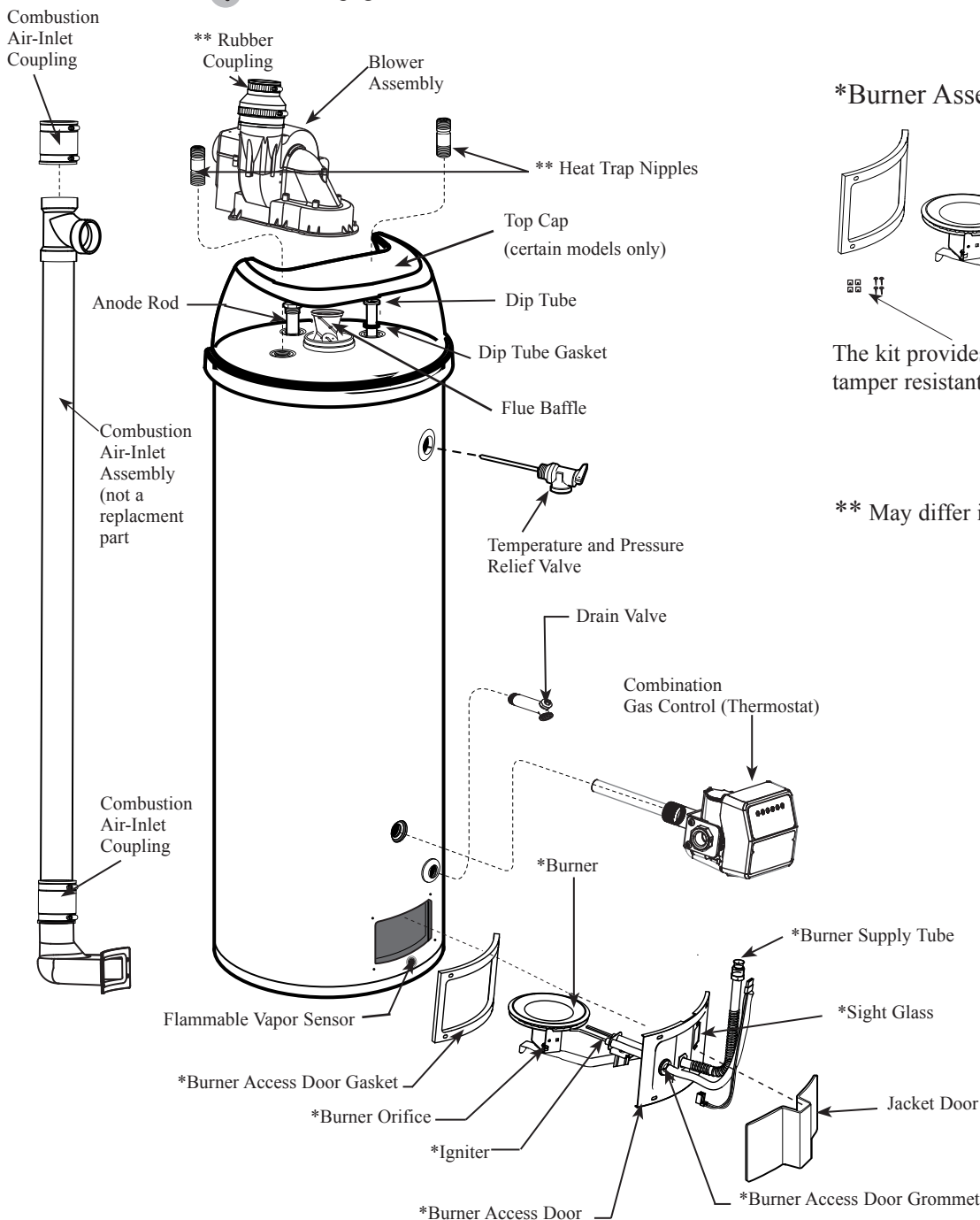

### \*Burner Assembly Kit

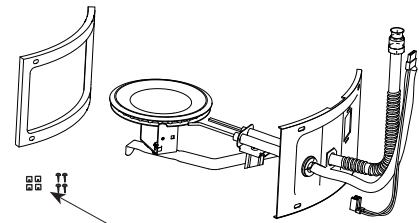

The kit provides extra speed clips and tamper resistant screws.

\*\* May differ in actual appearance.

# IF YOU NEED SERVICE



1. Should you have any questions about your new water heater, or if it requires adjustment, repair, or routine maintenance, it is suggested that you first contact your installer, plumbing contractor or previously agreed upon service agency. In the event the firm has moved, or is unavailable, refer to the telephone directory, commercial listings or local utility for qualified service assistance.
2. Should your problem not be solved to your complete satisfaction, you should then contact the Manufacturer's National Service Department at the following address:

1241 Carwood Court  
Montgomery, Alabama 36117  
Phone: 1-800-432-8373

When contacting the manufacturer, the following information will be requested:

- a. Model and serial number of the water heater as shown on the rating plate attached to the jacket of the heater.
- b. Address where the water heater is located and physical location.
- c. Name and address of installer and any service agency who performed service on the water heater.
- d. Date of original installation and dates any service work was performed.
- e. Details of the problems as you can best describe them.
- f. List of people, with dates, who have been contacted regarding your problem.

## Important Instructions for the Commonwealth of Massachusetts

The Commonwealth of Massachusetts requires compliance with regulation 5.08: Modifications to NFPA-54, Chapter 10 : 248 CMR 4.00 and 5.00 for installation of through – the – wall vented gas appliances as follows:

(1) Revise NFPA-54 section 10.5.4.2 by adding a second exception as follows:

Existing chimneys shall be permitted to have their use continued when a gas conversion burner is installed, and shall be equipped with a manually reset device that will automatically shut off the gas to the burner in the event of a sustained back-draft.

(2) Revise 10.8.3 by adding the following additional requirements:

(a) For all side wall horizontally vented gas fueled equipment installed in every dwelling, building or structure used in whole or in part for residential purposes, including those owned or operated by the Commonwealth and where the side wall exhaust vent termination is less than seven (7) feet above finished grade in the area of the venting, including but not limited to decks and porches, the following requirements shall be satisfied:

1. **INSTALLATION OF CARBON MONOXIDE DETECTORS.** At the time of installation of the side wall horizontal vented gas fueled equipment, the installing plumber or gasfitter shall observe that a hard wired carbon monoxide detector with an alarm and battery back-up is installed on the floor level where the gas equipment is to be installed. In addition, the installing plumber or gasfitter shall observe that a battery operated or hard wired carbon monoxide detector with an alarm is installed on each additional level of the dwelling, building or structure served by the side wall horizontal vented gas fueled equipment. It shall be the responsibility of the property owner to secure the services of qualified licensed professionals for the installation of hard wired carbon monoxide detectors

a. In the event that the side wall horizontally vented gas fueled equipment is installed in a crawl space or an attic, the hard wired carbon monoxide detector with alarm and battery back-up may be installed on the next adjacent floor level.

b. In the event that the requirements of this subdivision can not be met at the time of completion of installation, the owner shall have a period of thirty (30) days to comply with the above requirements; provided, however, that during said thirty (30) day period, a battery operated carbon monoxide detector with an alarm shall be installed.

2. **APPROVED CARBON MONOXIDE DETECTORS.** Each carbon monoxide detector as required in accordance with the above provisions shall comply with NFPA 720 and be ANSI/UL 2034 listed and IAS certified.

3. **SIGNAGE.** A metal or plastic identification plate shall be permanently

mounted to the exterior of the building at a minimum height of eight (8) feet above grade directly in line with the exhaust vent terminal for the horizontally vented gas fueled heating appliance or equipment. The sign shall read, in print size no less than one-half (1/2) inch in size, "GAS VENT DIRECTLY BELOW. KEEP CLEAR OF ALL OBSTRUCTIONS".

4. **INSPECTION.** The state or local gas inspector of the side wall horizontally vented gas fueled equipment shall not approve the installation unless, upon inspection, the inspector observes carbon monoxide detectors and signage installed in accordance with the provisions of 248 CMR 5.08(2)(a)1 through 4.

(b) **EXEMPTIONS:** The following equipment is exempt from 248 CMR 5.08(2)(a)1 through 4:

1. The equipment listed in Chapter 10 entitled "Equipment Not Required To Be Ventted" in the most current edition of NFPA 54 as adopted by the Board; and

2. Product Approved side wall horizontally vented gas fueled equipment installed in a room or structure separate from the dwelling, building or structure used in whole or in part for residential purposes.

(c) **MANUFACTURER REQUIREMENTS - GAS EQUIPMENT VENTING SYSTEM PROVIDED.** When the manufacturer of Product Approved side wall horizontally vented gas equipment provides a venting system design or venting system components with the equipment, the instructions provided by the manufacturer for installation of the equipment and the venting system shall include:

1. Detailed instructions for the installation of the venting system design or the venting system components; and

2. A complete parts list for the venting system design or venting system.

(d) **MANUFACTURER REQUIREMENTS - GAS EQUIPMENT VENTING SYSTEM NOT PROVIDED.** When the manufacturer of a Product Approved side wall horizontally vented gas fueled equipment does not provide the parts for venting the flue gases, but identifies "special venting systems", the following requirements shall be satisfied by the manufacturer:

1. The referenced "special venting system" instructions shall be included with the appliance or equipment installation instructions; and

2. The "special venting systems" shall be Product Approved by the Board, and the instructions for that system shall include a parts list and detailed installation instructions.

(e) A copy of all installation instructions for all Product Approved side wall horizontally vented gas fueled equipment, all venting instructions, all parts lists for venting instructions, and/or all venting design instructions shall remain with the appliance or equipment at the completion of the installation.