



SIDEWINDR
Iron & Sulfur Filter

Installation / Operation Manual

ABOUT YOUR SYSTEM

The **Sidewindr** uses the air we breath to naturally reduce the effects of Iron, Manganese and Sulfur Gas. By introducing oxygen to the water, contaminants chemically change to a physical particle that can be mechanically filtered out of this water. This natural process called Oxidation, is usually accomplished in other systems by using chemicals such as chlorine or potassium permanganate. Since the Sidewindr does not use chemicals to treat the water, maintenance and chemical byproducts associated with these types of systems is eliminated. The energy required to operate this system is provided by using extra power that is available in your well pump to inject free air into the water. There are several normal side effects that may or may not occur when water is treated in this manner:

1. Cloudy or milky appearance to the treated water.

This side effect is usually more pronounced when the Iron, Manganese or Sulfur Gas levels are low. Since the Sidewindr uses oxygen for the treatment of these contaminants, it can be expected to have some amount left over in the treated water. The higher the contamination levels are, the less oxygen there will be. It is the oxygen that gives the cloudy or milky appearance. Once the faucet is opened and the water is drawn, pressure is released and allows the oxygen to escape. This usually will take from a few seconds to a minute depending on the amount of oxygen and the pressure. This noticeable side effect tells you the system is working properly and also will actually enhance the palatability of the water. It's oxygen that gives water it's fresh, crisp taste.

2. Sputtering or slight coughing from the hot water side faucets.

This is a normal phenomenon that usually occurs first thing in the morning. As the highly oxygenated Sidewindr water is exposed to heat in the hot water tank a small amount of oxygen will separate. The longer the water is allowed to sit in the hot water tank, the more this will be noticed.

Usually, this will only occur if the hot water is allowed to sit idle for eight (8) hours or more. Consequently, when hot water is drawn after an extended period of no water use, a slight sputtering or coughing may be experienced for a few seconds. If this causes the hot water to splash out of the sink, the problem is reduced by simply turning on the cold water first and blending in the hot for several seconds. If there is a large amount of free air noticed on the cold water side, there is a possible malfunction of the system and your Clearion Dealer should be contacted to service the unit.

FCC Compliance Statement:

http://www.chandlersystemsinc.com/files/FCC_Compliance_Statement.pdf

Industry Canada Compliance Statement:

http://www.chandlersystemsinc.com/files/Industry_Canada_Compliance_Statement.pdf

One or more features of this product are covered by U.S. patents, visit <http://www.watersoftinc.com/patents.php> for more information.

General Specifications..... Page 4

Valve Mounting Instructions..... Page 5

Installation Requirements..... Page 6

Set Up Utilizing Bluetooth App Page 10

Set Up Using Buttons and Display on Valve..... Page 13

Master Programming..... Page 16

Control Valve Power Assembly..... Page 18

Valve Body Assembly..... Page 20

Tank Assembly..... Page 22

Bypass Assembly..... Page 24

Service Instructions..... Page 25

Troubleshooting..... Page 27

Error Codes..... Page 28

Warranty..... Page 30

Register Your Product

Online at

www.watersoftinc.com



Specifications

General Specifications	SW10	SW13
Smart Blend Media Capacity (cu ft)	1.5 cu. ft.	2.5 cu. ft.
Mineral Tank Size	10 x 54	13 x 54
Service Flow Rate - Continuous (gpm)	5	8
Service Flow Rate - Intermittent (gpm)	7	10
Backwash Flow Rate (gpm)	5.0	7.0
Gallons Used / Backwash	106	146
Space Required (D x W x H)	10 x 21 x 61	13 x 24 x 61
Approximate Shipping Weight	160	236

General Specifications	SW10S	SW13S
Catalytic Carbon Media Capacity (cu. ft.)	1.5 cu. ft.	2.5 cu. ft.
KDF Cubes	1.5 lbs	2.5 lbs
Mineral Tank Size	10 X 54	13 X 54
Service Flow Rate - Continuous (gpm)	5	8
Service Flow Rate - Intermittent (gpm)		10
Backwash Flow Rate (gpm)	5.0	7.0
Gallons Used / Backwash	106	146
Space Required (D x W x H)	10 x 21 x 61	13 x 24 x 61
Approximate Shipping Weight	160	236

WARNING

Lubricants

Do NOT use Vaseline, oils, hydrocarbon lubricants or spray silicone anywhere! Petroleum base lubricants will cause swelling of o-rings and seals. The use of other lubricants may attack plastic Noryl®. It is recommended that Dow Corning® silicone grease be used as a lubricant for all control valves. Dow Corning® 7 Release Compound is used in the manufacture of Chandler Systems control valves. (Part # LT-150)

Sealants

Pipe dope and liquid thread sealers may contain a carrier that attacks some plastic materials. It is recommended that Teflon® tape be used to seal plastic Noryl® threaded fittings.

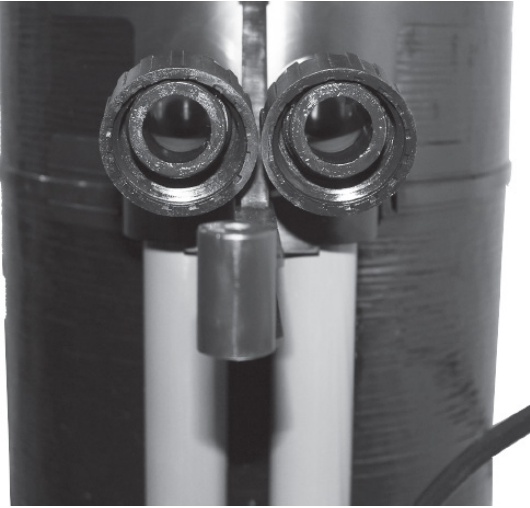

1. Connect the "in and out" plumbing connections loosely. Use caution with lubricated O-rings.

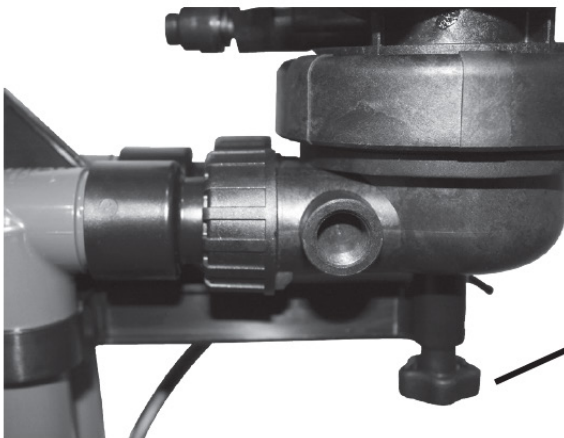

2. Attach the mounting screw in the bottom before completely tightening the plumbing connections.

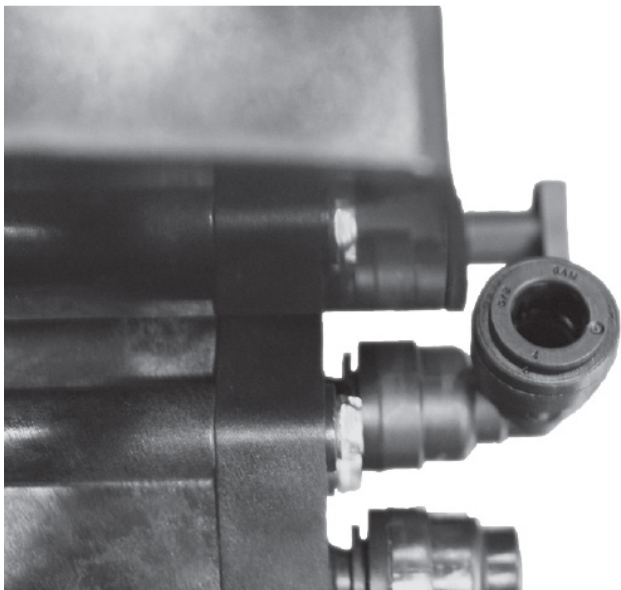

3. Attach air-intake tubing to push-lock elbow on side of control valve. Ensure that tube is pushed in beyond the O-ring, approximately 5/8".

Installation Requirements

Make sure you have level floor position ahead of piping into water heater.

Unit must be installed at least 10 feet ahead of the inlet to a water heater to prevent damage due to back-up hot water.

DO NOT install the unit in an area of direct sunlight or where freezing temperatures may occur!

Locate the unit near an unswitched, 120 volt / 60 Hz grounded electrical outlet.

Check for distance and proper drain installation (e.g. floor drain, washing machine standpipe).

Determine type and size of piping required for filter connection (e.g. copper, galvanized, PVC plastic).

Note: If household plumbing is galvanized and you intend to make the installation with copper (or vice versa), obtain di-electric unions to prevent dissimilar metal corrosion.

Note Where the drain line is elevated above the control valve or exceeds 20 feet in length to reach the drain, use 3/4" I.D. drain line tubing instead of 1/2" I.D. Drain line tubing is not included.

Caution: If sweat soldering copper pipe (remember to always use lead free solder and flux), cover yoke and bypass valve with wet rags to prevent heat damage to connections and control valve. If using PVC or plastic pipe, primers and solvent cements specifically recommended for use with potable water are required.

Note: All plumbing lines not requiring filtered water should be connected "upstream" of the equipment installed. A one-way check valve must be installed between the secondary service line and inlet to the filter to prevent backflow.

(See Typical Installation Diagrams.)

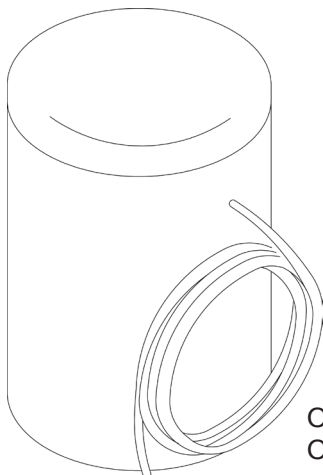
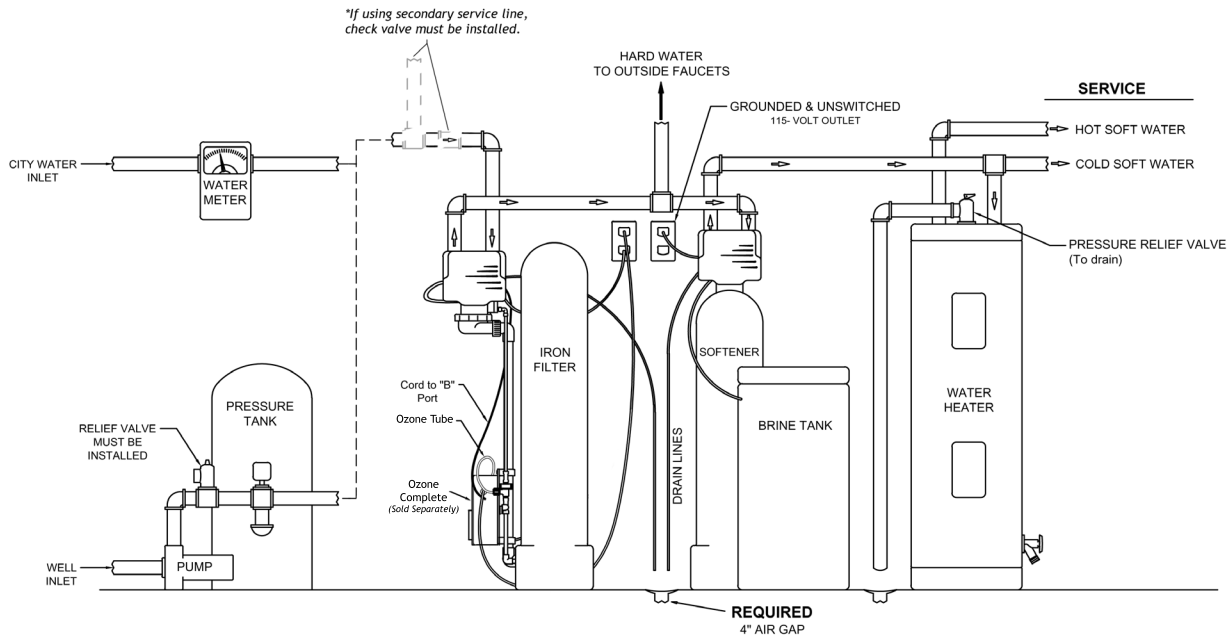

Oxy-08NP Optional
Oxyclean

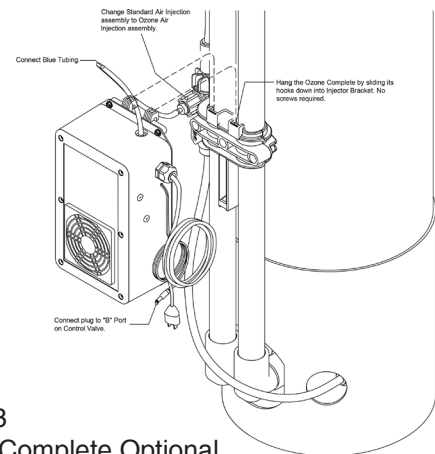

OXY-03
Ozone Complete Optional

Installation Procedure

- Water Supply Connection and Bypass Valve -

To allow for filter servicing, swimming pool filling or lawn sprinkling, a manual Bypass Valve has been installed at the factory. The Bypass allows raw water to be manually routed around the filter.

1. Position filter at desired location for installation. If a water softener is to be installed, the filter should be positioned first and then the softener. (See Installation Diagrams.)
2. The filter media is shipped separately from the mineral tank. The tank must be loaded with media after tank has been placed at the desired location.
 - A. Remove the tank closure by unscrewing from the tank.
 - B. Use cap provided to place over top of distributor tube to prevent media from entering tube while filling.
 - C. Place media funnel in hole on top of tank.
 - D. Pour several gallons of water in the tank. (Fill tank about 1/3 full.)
 - E. Pour in the required filter media. Gravel underbedding has been installed at the factory. The required quantity & type of media is listed in the filter specifications.
 - F. After installing filter media, add the included pack of aeration balls or KDF cubes.
 - G. After filling the tank with material, use a garden hose or several buckets to fill the tank with water.
 - Note:** This will permit the filtering media to become soaked while preparing the installation and will prevent the control valve from being plugged with floating media on initial backwash.
 - H. Remove funnel and clean filter media from tank threads.
 - I. Remove cap from distributor tube.
 - J. Replace tank closure on mineral tank.
3. Turn OFF main water supply and OPEN nearest faucet to relieve pressure.
4. Cut main line and install appropriate elbows and extensions.

Caution: Raised arrows located on the sides of control valve body and bypass valve indicate proper direction of water flow. Install inlet and outlet piping in direction of arrows. It is recommended that a vacuum breaker be installed on the inlet plumbing.

- Drain Line Connection -

1. The drain line flow control assembly is pre-assembled for your convenience. Should you choose to hard plumb the drain line, please remove the barb fitting. The flow control housing can be removed by removing the clip and pulling straight out on housing.

Note: When re-installing the drain line flow control housing, be sure you hear and feel the O-Ring pop into place before inserting the clip.

2. Install 1/2" I.D. drain line tubing (not included) from hose barb to an open drain. A 4" gap between end of the drain line and the open drain is required to prevent waste water backflow. Keep the drain line as short as possible. An overhead drain line can be used if necessary, but should discharge below the control valve. A syphon trap (taped loop) at the outlet of the drain line is advisable to keep the drain line full and assure correct flow during backwash. Elbows or other fittings must be kept at a bare minimum.

Note: Where the drain line is elevated above the control valve or exceeds 20 feet in length, 3/4" I.D. drain line tubing should be used.

- Electrical Connection -

1. Connect the power cord and plug power supply into a 115 volt / 60 Hz receptacle.

Note : Do not plug into an outlet controlled by a wall switch or pull chain that could inadvertently be turned off

Electronic Connections

P = Power Supply

**B = Powered in Air Replenish Step Only
(Cycle #1)**

S = Powered for Entire Backwash Cycle



- System Start Up Procedure -

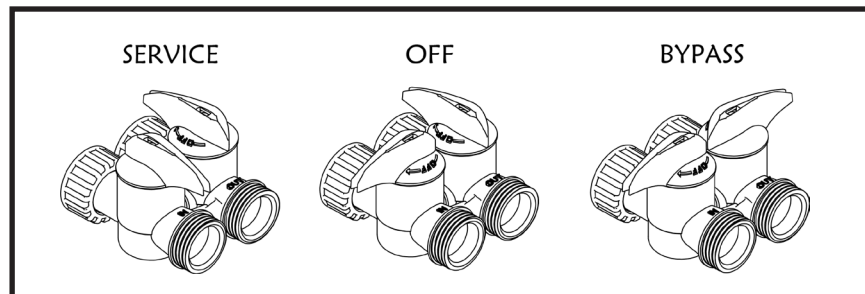

IMPORTANT NOTE: Tank should be filled with water and media must have been soaking for at least 1 hour before initial pressurization

1. After all plumbing and drain line connections have been made, turn main water supply back on and check for leaks.
2. Ensure that the bypass valve is in the BYPASS position, and then cycle the control valve to RAPID RINSE. Once the rapid rinse step is reached, slowly open the bypass valve to the service position, allowing water to flow down through mineral tank and out the drain line. Let it continue to run for the entire rapid rinse step (5 minutes). There may be colored water or media fines during this initial flow.
3. Once the rapid rinse ends, leave the system in service, and open a cold, treated water tap. Let water run for several minutes to allow air and any media fines to be released from the lines. Once air is evacuated and water runs clear, close the tap.

NOTE: Any time media (other than very fine mineral on initial startup) is apparent in the service lines, it usually indicates one of the following problems:

- A. The unit is plumbed in backward allowing the media to be carried in the service line.
- B. The distributor tube inside the tank is not seated inside the valve or is damaged.

4. No further regeneration should be necessary at this time. If left at the default settings, the filter will automatically initiate an air replenish cycle each night and will backwash every six days. If desired, these settings can be changed in the main menu, or from the "advanced settings" screen in the Legacy View app.

- Final Checkout -

1. Be certain that the bypass valve is in Service position and main valve is completely on.
2. Check electrical supply to be certain the cord is connected to an uninterrupted 115 volt outlet.
3. Be certain to REGISTER YOUR PRODUCT online at www.watersoftinc.com
4. Leave this manual with the homeowner.

Important Notice - The plumbing system, piping, pressure tank, hot water tanks, softeners, etc. that have been exposed to iron bearing water may need to be cleaned of the precipitated iron that has been collected in them or iron bleed thru may be a problem. We suggest all tanks be drained and flushed thoroughly.



For simplified set up and control, please install the Legacy View on a compatible Bluetooth 4.0+ enabled smart phone or tablet.

1. Download and install the Legacy View app from the Google Play Store, Apple App Store



2. Open the Legacy View app

- Choose a valve device at any time from the list of available devices to connect to by clicking on it.
- If the valve you want to connect to doesn't show up, or there is a problem connecting to a device you can press the "Scan for Devices" button or the Legacy View logo at any time to refresh the list and start the process over.
- If the valve device is a BTLE valve and it has a password other than the default password, the first time you connect to it the app will ask you to enter the password. After entering it the first time you should not need to enter it again unless it changes.



3. BTLE Valve devices can be updated by the App. When the app is updated from the Google Play Store or the Apple App Store, it may contain an updated firmware program for the valve devices. These updates could contain new features or operational improvements. It is up to the user to allow these updates to be sent to the valve device. Uploading a new program takes approximately 1 minute.

Dashboard

NOTE: Consult your dealer before making any changes

From the **Dashboard**, all items in **ORANGE** can be changed, while blue fields are informational only.



If you are unsure about the function of the field click the  for more information.

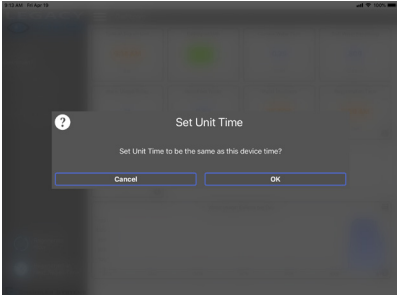

Change Time of Day (Press "SET" to set time automatically based on device).

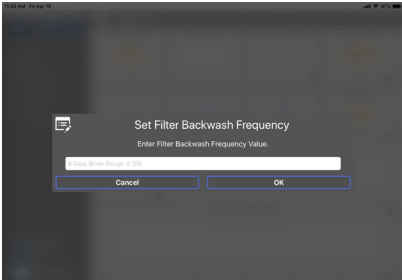

For Filters:
Set Backwash Frequency
This sets the amount of day between backwash cycles

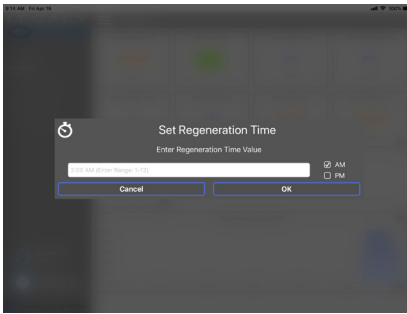

Set Regeneration Time
Example: For 2a.m., just type 2, choose a.m., and press 'OK'
Note: If you have a filter and a softener the valves should be set to regenerate at different times. Factory default times are 12a.m. for filters, and 2 a.m. for softeners.

Advanced Settings

NOTE: Consult your dealer before making any changes. We do not recommend changing Advanced Settings unless you have a good understanding of the system operation.

From the **Advanced Settings**, all items in **ORANGE** with a "set" button can be changed.

Status and History

From the **Status and History**, all items in **ORANGE** can be reset.

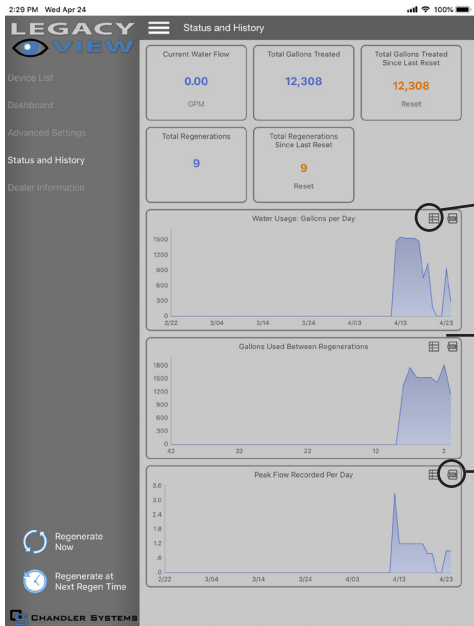

Pressing this icon will show a list of the data that is in the graph.

Touch any graph to enlarge and see details. Enlarged graphs are able to be zoomed in by pinching with two fingers. (Enlarged graph shown below)

Pressing the .csv logo in the corner will allow the graph data to be exported and shared.

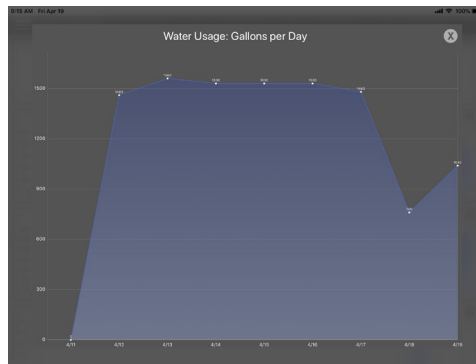

Enlarged graph showing water usage

1. Start a regeneration or backwash cycle

Option 1:

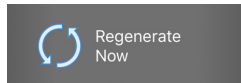

Click the "Regenerate Unit Now."

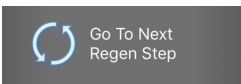

Once a regeneration has been started, if you would like to force the unit into the next cycle step click "Go to Next Regeneration Step".

Option 2:

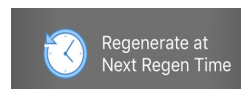

"Regenerate Unit at Next Regen Time" button
This will take the system into a backwash cycle at the next regeneration time.

Setting Up and Controlling the System Using the Buttons on the Valve

Main Menu

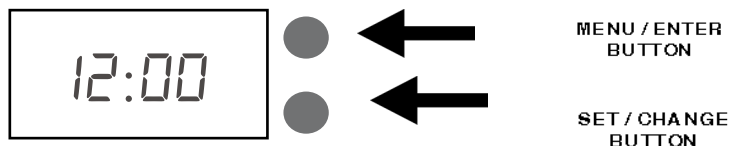

1. To enter Main Menu, press the **Menu/Enter** button.
(Time of Day will flash)

2. To set the **Time of Day**, press the **Set/Change** button.
(First digit will flash) Example [12:00]
 - To change digit value, press the **Set/Change** button.
 - To accept the digit value, press the **Menu/Enter** button.
 - Next digit will flash to begin setting.
 - Once the last digit display is accepted, all digits will flash.

3. To set **A.M.** or **P.M.**, press the **Menu/Enter** button. Example [A]
 - To change digit value, press the **Set/Change** button.
 - To accept the digit value, press the **Menu/Enter** button.
 - Once A.M. or P.M. is accepted, the next menu item will flash.

4. Days Between Backwash
 - Press Menu / Enter Button. This display is used to set the maximum amount of time (in days) the unit can be in service without a backwash. This option setting is identified by the letter 'A' in the left digit. Backwash will begin at the set Backwash Time. A "00" setting will cancel this feature. The Max Value for this item is 29.
 Example: Every 6 days (A - 06) (Default Setting)
 To Adjust this Value Press the Set / Change Button.
 To Accept the Digit Value Press the Menu / Enter Button.

5. To set the **Number of Days between Air Draw Cycles** (d), press the **Set/Change** Button
 - Repeat instructions from step (2) Example (d - 01)
 - Notes: 1) Maximum value is 9.
 - 2) If value set to 0, air draw is turned off, but an air cycle will still be completed when backwash cycle occurs. If the Number of Days between Air Draw Cycles is set to a higher number of days than the Number of Days between Backwash Cycles, it will have no effect. In order to turn off all cycles, both the Days between Backwash and Days between Air Draw Cycles must be set to 0.
 - 3) Default setting is 1 day.

6. To Exit Main Menu, press the **Menu/Enter** button.
Note: If no buttons are pressed for 60 seconds, the Main Menu will be exited automatically.

Normal Operation

1. Home Display

- a. Alternates between the display of Time of Day and Number of Days until the Next Backwash.
 - Days Remaining until the Next Backwash will count down from the entered value until it reaches 1 day remaining.
 - A Backwash Cycle will then be initiated at the next designated regeneration time.

2. Battery Back-Up (Uses a standard 9-volt alkaline battery.)

Features of Battery Back-Up:

- During power failures, the battery will maintain the time of day as long as the battery has power.
The display is turned off to conserve battery power during this time. To confirm that the battery is working, press either button and the display will turn on for five (5) seconds.
- If power failure occurs while system is regenerating, the Signature 2 valve will motor to a shut off position to prevent constant flow to drain. Depending upon system pressure and other factors, it is possible to observe a reduced flow to drain during this step. After power is restored, the valve will return and finish the cycle where it left off prior to the power interruption.
- When used without battery back-up, during a power failure, the unit stops at its current point in the regeneration position and then restarts at that point when the power is re stored. The time will be offset by the increment of time the unit was without power, so it is necessary to reset the time of day on the unit. No other system will be affected.

Starting Extra Regeneration Cycle

1. To Start **Delayed Extra Cycle**

- If Days Remaining Until Next Regeneration does not read '1', press and hold the **Set/Change** button for 3 seconds until the display reads '1'.
- Regeneration cycle will initiate at the next designated regeneration time.

Example (1) -

2. To start **Immediate Extra Cycle** First complete above step.

- With Days Remaining Until Next Regeneration at '1'.
- Press and hold the **Set/Change** button.
- After 3 seconds, the regeneration cycle will begin.

3. To **Fast Cycle** thru regeneration First complete above 2 steps.

Note: Press and hold the **Set/Change** button for 3 seconds to advance to the next cycle step. Fast Cycle is not necessary unless desired to manually step through each cycle step.
(Repeat until valve returns to the home display)

Sidewindr Backwash Cycle Step Explanations

Step 1: Air Release Step

-For approximately 6 minutes, Non-adjustable

This position slowly opens the treatment tank to the drain. This allows air in the top of the tank to be gently released out the drain.



Step 2: Backwash Step

- Default of 10 minutes

This position does a high flow rate rinse in the opposite direction of normal water flow. This rinses any physical particles filtered by the media in the unit down the drain.

Step 3: Rest Step

- Default of 0 minutes

This position is a rest position. If needed, this position is used to give a well time to recover after running water in the backwash step.

Note: Depending upon system pressure and other factors, it is possible to observe a small amount of flow to drain in the rest cycle.

Step 4: Air Replenish / Oxyclean NP Injection

- Default of 20 minutes

- Ozone Optional

- For Oxyclean operation, see Master Programming Mode

This position draws in the air and chlorine into the filter tank. The air is used to oxidize iron and sulfur in the water so the filter media can remove it. If the Pulse Chlorine setting is enabled and an Oxyclean NP is installed this cycle will inject approximately 8 - 16oz of chlorine solution into the filter to disinfect the media bed and improve filtration. See "Pulse Chlorine Setting" for more information.

Step 5: Rapid Rinse Step

- Default of 5 minutes

This position runs a higher rate rinse in the same direction as normal water flow. This packs the filter media bed and gets the unit ready for service by rinsing any untreated water to the drain.

- The default time at which backwash or air draw cycle will occur is 12:00 a.m.

- When the valve is between positions, the display will flash the number of the step it is moving towards.

The motor's run direction during a particular regeneration cycle step is indicated by the rotation direction of the last 2 digit displays.

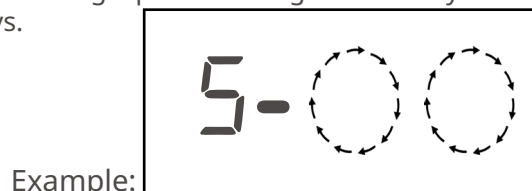

Master Programming Mode

To enter Master Programming Mode, press and hold both buttons for 5 seconds.

Note: All Master Programming functions have been preset at the factory. Unless a change is desired, it is **NOT** necessary to enter Master Programming Mode.

1. Regeneration Time (r)

Example [r 12A]

- The time of day at which regeneration may take place is designated by the letter “r”.
- Default regeneration time setting is 12A
- The first display digit indicates A.M. or P. M. To change the value, press the **Set/Change** button.
- Press **Menu/Enter** button to accept the value and move to the next digit.
- The second and third display digits indicate the hour at which the regeneration will occur.
- Change the digits with the **Set/Change** button and accept with the **Menu/Enter** button.
- After the entire display flashes, press the **Menu/Enter** button to move to the next menu item.

2. Backwash Cycle Step Times* (Steps 2, 3, 4, 5)

Example (3 - 20)

- The next 4 displays set the duration of time in minutes for each backwash cycle step.
- The step number which is currently modifiable is indicated on the far left of the display screen.
- The number of minutes allotted for the selected backwash step is displayed on the far right.
- Change the digit values using the **Set/Change** and **Menu/Enter** buttons as described above.

Note on Air Draw Cycle (4):

The longer the unit is set to remain in the Air Draw cycle (4), the more air is drawn into the system. A default setting of 20 minutes draws air down to the level of a normal media bed height. If the system needs more air, increase the time setting for step (4) or decrease the number of days between air draw cycles (In Main Menu).

3. Pulse Chlorine Setting (J)

Example [J 02]

- The default pulse chlorine setting is 2.
- Setting pulse chlorine to 0 will disable it.
- The maximum value for pulse chlorine is 4.
- Change the digit values using the **Set / Change** and **Menu / Enter** buttons as described above.

The pulse chlorine setting adjusts how many times and how much chlorine is injected into the system during the Air Replenish / Oxyclean NP Injection cycle (Step 4). The table below indicates the approximate amount of chlorine solution that will be injected for the different settings.

Pulse Chlorine Setting	Approx. Total Amount of Chlorine	Description
0	0 oz.	Oxyclean option is off, no chlorine will be injected.
1	8 oz.	Chlorine will be injected in 1 pulse at the beginning of the cycle step.
2	10 oz.	Chlorine will be injected in 2 pulses, at the beginning of each ½ of the cycle step.
3	12 oz.	Chlorine will be injected in 3 pulses, at the beginning of each 1/3 of the cycle step.
4	16 oz.	Chlorine will be injected in 4 pulses, at the beginning of each 1/4 of the cycle step.

Notes:

- If the pulse chlorine setting is on (1-4) the minimum time for the Air Replenish/Oxyclean NP Injection cycle step is forced to 20 minutes.
- If the pulse chlorine setting is set to 4 the minimum time for the Rapid Rinse cycle step is forced to a minimum of 5 minutes.
- Chlorine injection only occurs on full backwash cycle nights (Based on Filter Backwash Frequency setting). It does not occur on air recharge cycle nights.
- The Oxyclean NP is an optional accessory, the pulse chlorine setting will only be meaningful if it is installed.

4. **Bluetooth Enabled** *bE - 1* (ON)
 bE - 0 (OFF)

- Toggle the setting with the **Set / Change** button.

5. **Bluetooth Password** *bbPP* is displayed for one second, then password is displayed.

- Change the digit values using the **Set / Change** and **Menu / Enter** buttons as described above.

6. To Exit the Master Programming Mode, press the **Menu/Enter** button until time of day returns.

Note: If no buttons are pressed for 60 seconds, the Master Programming Mode will be exited automatically.

Control Valve Powerhead Assembly

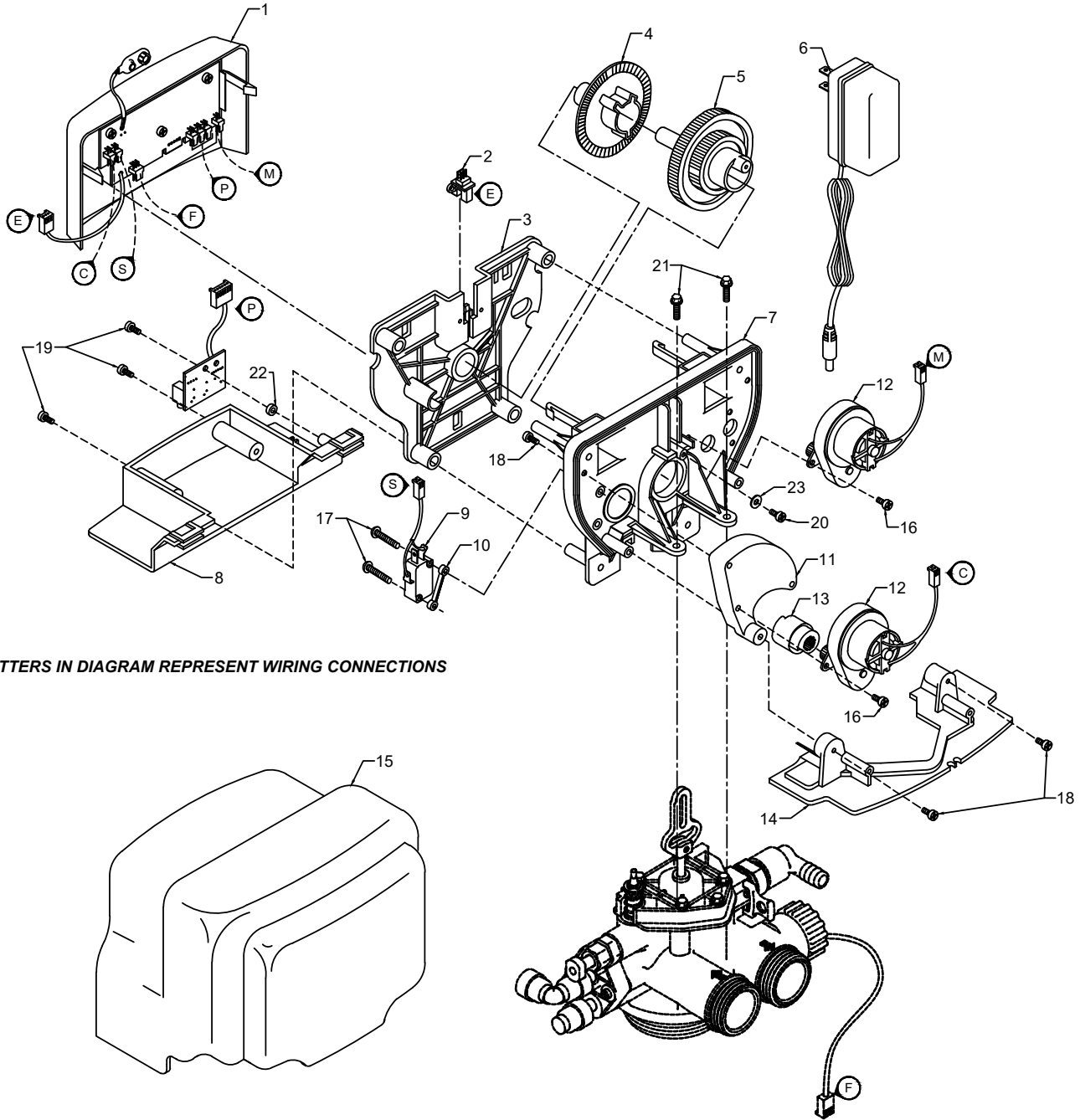

LETTERS IN DIAGRAM REPRESENT WIRING CONNECTIONS

REF	DESCRIPTION	PART NO.	QTY
0	Powerhead Assy.	20015X100	1
1	Circuit Board Assy.	22015X101	1
2	Encoder	20001X124	1
3	Front Plate	20001X004	1
4	Encoder Wheel	20001X007	1
5	Main Gear	21001X120	1
6	Power Supply	20001X125	1
7	Back Plate	20001X005	1
8	Lower Front Base For Cover	20111X002	1
9	Microswitch	20251X113	1
10	Switch Spacer	20111X004	1
11	Brine Motor Mount	20111X006	1
12	Legacy View Motor Assy.	20016X006	2
13	Brine Cam	20111X005	1
14	Lower Back Base For Cover	20111X003	1
15	Valve Cover	20111X000	1
16	6-32 X 5/16" Phillips, Pan Head	SC2	4
17	4 X 3/4" Phillips, Oval Head	SC3	2
18	6 X 1/2" Slotted, Hex Head Black	SC9	3
19	6 X 1/2" Phillips, Pan Head	SC10	3
20	6 X 1/2" Slotted, Hex Head	20001X003	1
21	10-24 X 3/4" Screw SST	20001X001	2
22	Circuit Board Washer	20111X014	1
23	6 X 1/2 Fenderwasher SST	20001X002	1

Sidewindr Valve Body Assembly

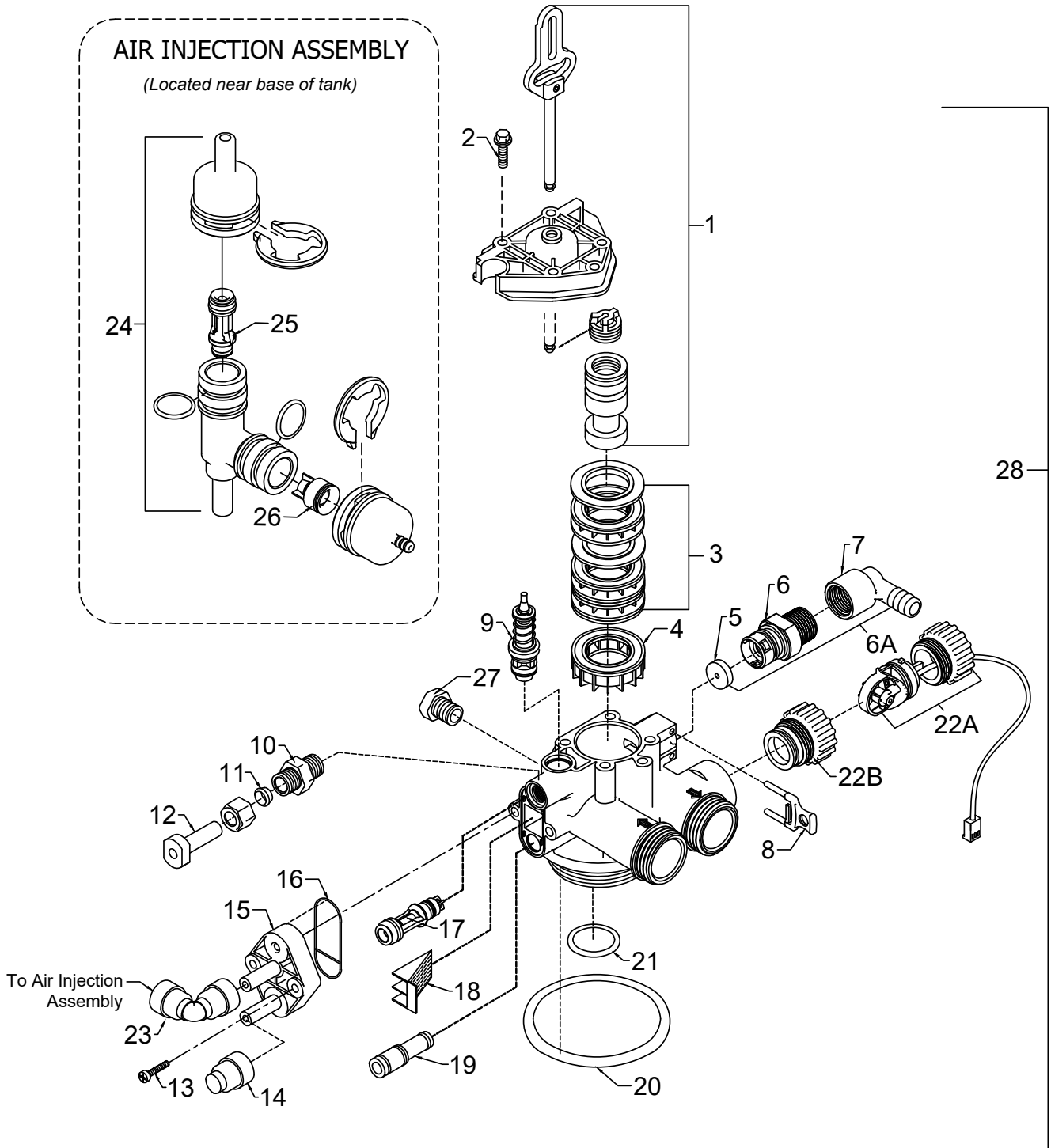

REF	DESCRIPTION	PART NO.	QTY
1	Piston Assembly Final Rinse	20009X231	1
2	10-24 X 3/4" Screw SST	20001X001	5
3	Seal and Spacer Kit	20561X253	1
4	End Spacer	N/S	1
5	Flow Control Button 5.0 GPM	20251X272	1
	Flow Control Button 7.0 GPM	20251X273	1
6	DLFC Housing	20017X100	1
6A	Flow Control Assy 5.0 GPM	20017X262	1
	Flow Control Assy 7.0 GPM	20017X264	1
7	Drain Line Hose Barb 90 ° Elbow	20017X266	1
8	Drain Retainer	20017X214	1
9	Brine Valve	20009X225	1
10	BLFC Assy. SST	20009X228	1
11	BLFC Ferrule 3/8"	20251X305	1
12	Plug 3/8"	20009X005	1
13	10-24 X 3/4" Screw SST	20001X226	2
14	3/8" Push Lock Plug	20009X010	1
15	Injector Cap	20009X001	1
16	Injector Seal	20001X224	1
17	Injector Assy. #1 White	20017X219	1
18	Injector Screen	20001X222	1
19	Injector Plug & O-Ring Assy	20001X217	1
20	Tank / Valve O-Ring	20561X205	1
21	Dist. O-Ring	20561X204	1
22a	Meter Assembly	20017X203	1
22b	Meter Plug w/ O-Ring	20017X201	1
23	3/8" Push Lock 90 ° Elbow	GA-Q0620626BV	1
24	Air Injector Check Assy	20017X010	1
25	Injector, White	20017X219	1
26	Check Valve	20111X011	1
27	1/4" NPT Cap	20018X035	1

Tank Assembly

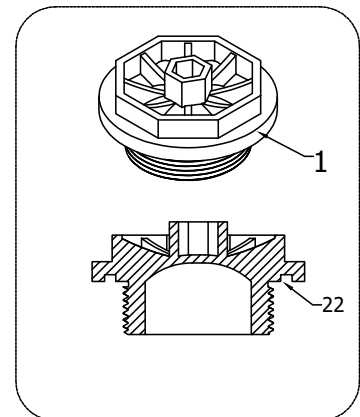
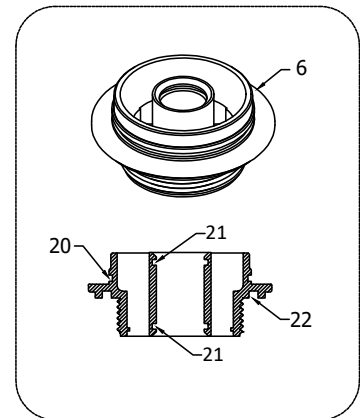
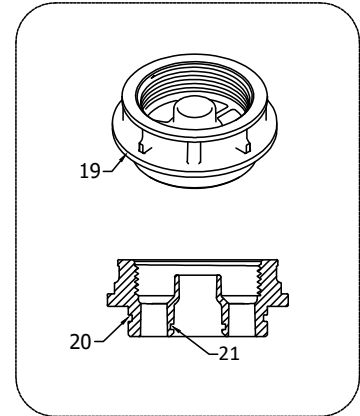
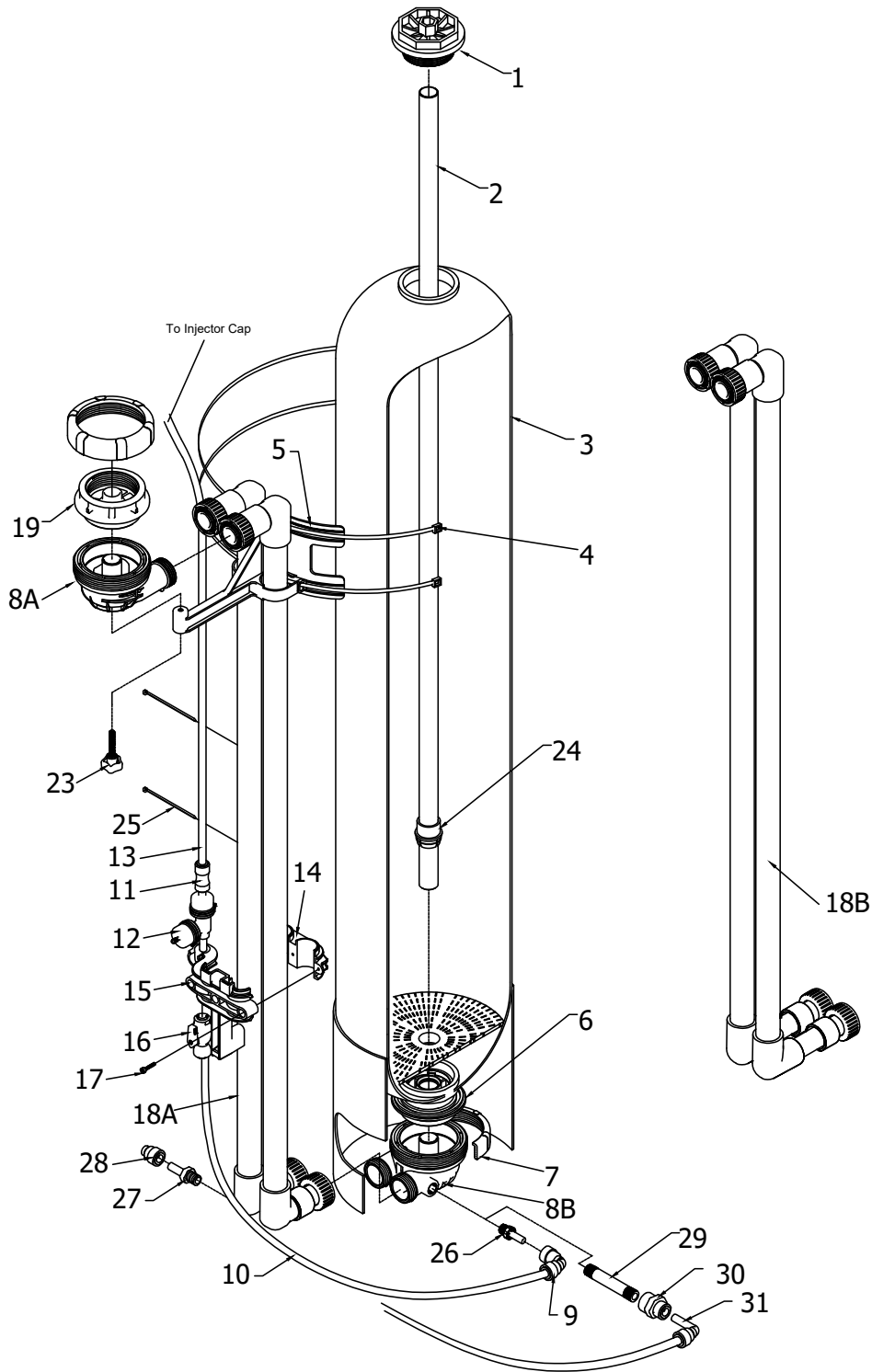

No.	Part No.	Description	Qty.
1	20015X044	Tank Cap	1
2	33012X001	Tank Distributor Tube <i>(per foot)</i>	4.5
3A	31054V000	10" Black Tank	1
B	31354V000	13" Black Tank	1
4	20015X035	Large Zip Tie	2
5	20015X011	Tank Bracket	1
6	20015X008	Tank Adapter	1
7	20015X007	Upflow Union Nut	2
8A	20015X010	Upflow Body	1
B	20015X010-D	Upflow Body Drilled	1
9	GA-Q0620626B	90 Degree Push Lock Elbow	1
10	57005X001	3/8" Brine Tubing, Blk 22"	1
11	GA-R0620626BV	Straight Coupler Push Lock	1
12	20018X011	Air Injector	1
13	57005X001	3/8" Brine Tubing, Blk 32"	1
14	70000X034	Bracket Retainer	1
15	70000X035	Sidekick Air Injection Bracket	1
16	20015X022	3/8" Push Lock Ball Valve	1
17	02105	Self Tapping Screw	2
18A	20015X019	10" Sidekick Main Feed Assembly <i>44" Pipe, Left and Right</i>	1
B	20015X201	13" Sidekick Main Feed Assembly <i>44" Pipe, Left and Right</i>	1
19	20015X029	Valve Adapter	1
20	20015X012	O-Ring <i>Parker No. ORM0300-07600N-70</i>	2
21	20561X204	O-Ring <i>ORM0300-02620 N-70</i>	2
22	20001X215	O-Ring, Tank	2
23	20015X020	Knob	1
24	R-DIP1050	Vortech Tube Adapter	1
25	N/A	Black Zip Tie for 3/8" Tubing	2
26	GA-S0660616B	3/8" NPT to 3/8" Push Lock Adapter Stem	1
27	GA-S0660416B	1/4" NPT to 3/8" Push Lock Adapter Stem	1
28	20009X005	3/8" Push Lock Plug	1
29	20015X017	3/8" SCH80 PVC Nipple <i>(13" unit only)</i>	1
30	20015X028	3/8" NPTF to Push Lock Adapter <i>(13" unit only)</i>	1
31	20015X021	3/8" Push Lock Stem 90 <i>(13" unit only)</i>	1

Bypass Assembly

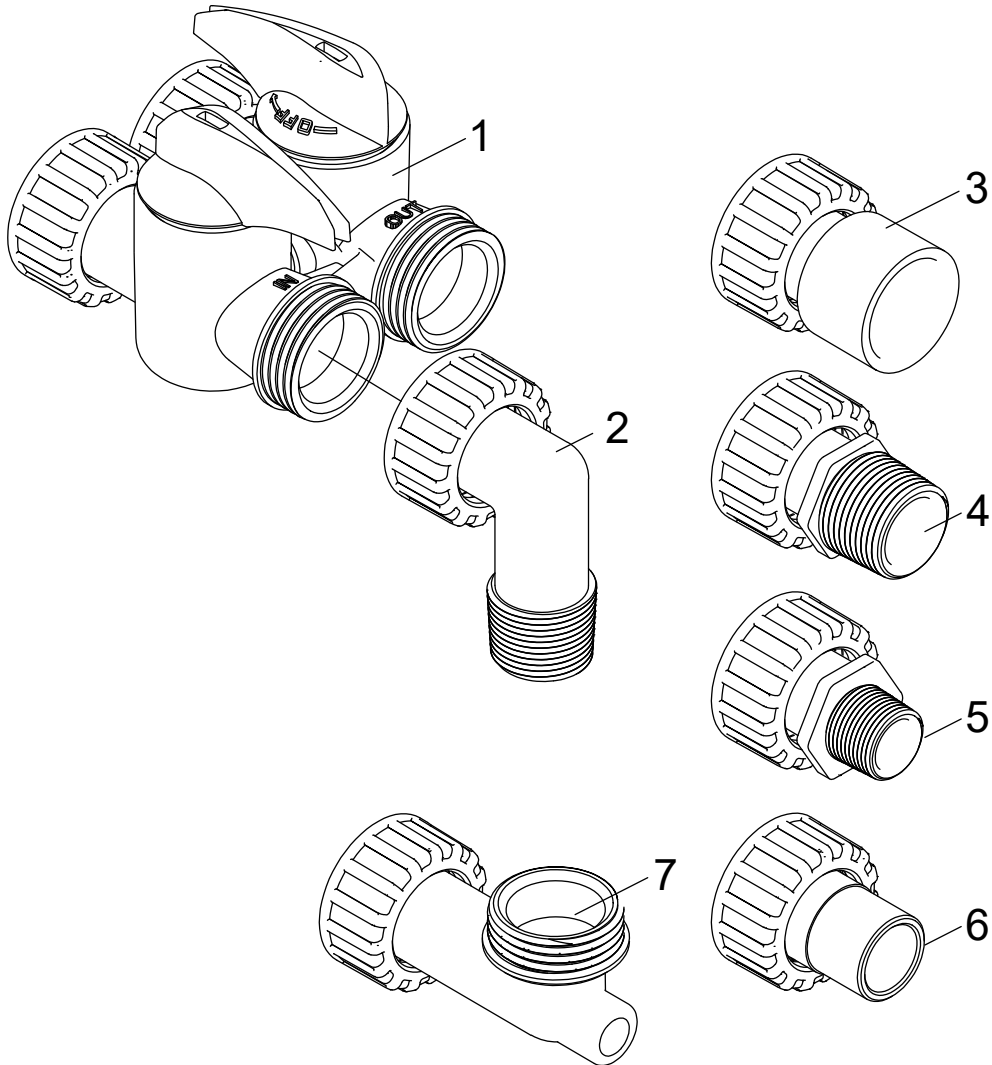

REF	DESCRIPTION	PART NO.
1	D15 Bypass (included with all units)	20017X283
2	1" NPT Elbow Set (included with all units)	20017X284
3	1" Female Straight Slip Set (optional)	20017X288
4	1" NPT Straight Set (optional)	20017X289
5	3/4" NPT Straight Set (optional)	20017X307
6	3/4" Female Straight Slip Set (optional)	20017X290
7a	Elbow, Vertical Adapter Blank (optional)	20017X295
7b	Elbow, Vertical Adapter 1/4" NPT Tapped (optional)	20017X294

A. General Preliminary Instructions

PERFORM BEFORE ALL SERVICING OPERATIONS

1. Turn off water supply to conditioner.
 - If the conditioner installation has a “three valve” bypass system, first open the valve in the bypass line, then close the valves at the conditioner inlet and outlet.
 - If the conditioner has an integral bypass valve, put it in the bypass position.
 - If there is only a shut off valve near the conditioner inlet, close it.
2. Remove cover and relieve water pressure in the conditioner by stepping the control into the back wash position momentarily. Return the control to the service position.
3. Unplug electrical cord from outlet.

B. To Replace Powerhead

1. Remove the control valve cover and disconnect the power supply.
2. Disconnect the meter cable from circuit board and feed back through control (if existing meter is being re-used)
3. Remove lower back base screws and detach lower back base.
4. Remove screw and washer at drive yoke. Remove powerhead mounting screws. The entire powerhead assembly will now lift off easily.
5. Put new powerhead on top of the valve. Be sure the drive pin on main gear engages slot in drive yoke (wide side of drive yoke upright must face to the left away from the motor).
6. Replace powerhead mounting screws. Replace screw and washer at drive yoke.
7. Reattach lower back base.
8. Reconnect meter signal, wire and power supply.
9. Reinstall cover.

C. To Replace Piston Assembly

1. Follow steps **A1 - A3**
2. Disconnect the meter signal wire from the circuit board.
3. Remove lower back base screws and detach lower back base.
4. Remove screw and washer at piston drive yoke. Remove powerhead mounting screws. The entire powerhead assembly will now lift off easily.
5. Remove piston retaining plate screws.
6. Pull upward on end of piston yoke until assembly is out of valve.
7. Inspect the inside of the valve to make sure that there is no foreign matter that would interfere with the valve operation.
8. Install new seals and spacers.
9. Take new piston assembly and push piston into valve by means of the end plug. Twist drive yoke carefully in a clockwise direction to properly align it with drive gear. Reinstall piston retaining plate screws.
10. Follow steps **B5 - B9**

D. To Replace Seals and Spacers

1. Follow steps **A1 - A3**.
2. Disconnect the meter signal wire from the circuit board.
3. Remove screw and washer at piston drive yoke. Remove powerhead mounting screws. The entire powerhead assembly will now lift off easily. Remove piston retaining plate screws.
4. Pull upward on end of piston rod yoke until assembly is out of valve. Remove seals and spacers. (**Note:** Special end spacer must be reused)
5. Lubricate new seals with silicone lubricant included in the seal and spacer kit. Make sure the special end spacer is properly seated in the valve body. Install new seals and spacers individually, pressing around the outer edge of each seal to make sure it is seated. (When all seals and spacers are seated properly, you will have a 1/4” of space between the top seal the the top of the valve body)
6. Follow Steps **C9 - C10**.

E. To Replace Meter

1. Follow steps **A1 - A3**
2. Unplug meter cable from front of circuit board.
3. Unscrew meter assembly nut from valve body.
4. Remove meter from valve body and clean or replace as necessary.
5. Reinstall meter, nut and cable.

F. To Replace Brine Valve

1. Follow Piston Replacement instructions. After the piston is removed, pull the brine valve from the valve body.
2. Inspect brine valve cavity in valve body and remove any foreign matter that would interfere with brine valve operation.
3. Apply silicone lubricant to brine valve O rings and push the new brine valve into the valve body.
4. Continue following Piston Replacement instructions to reinstall piston and powerhead

SYMPTOM	PROBABLE CAUSE	CORRECTION	
1. Fails to Regenerate Automatically	Power supply plugged into intermittent or dead power source	Connect to constant power source	
	Improper control valve programming	Reset program settings	
	Defective power supply	Replace power supply	
	Defective Drive motor	Replace motor	
2. Regeneration at Wrong Time	Time of day improperly set, due to power failure	Reset time of day programming and install 9-volt battery.	
	Regeneration time set improperly	Reset regeneration time programming	
3. Poor Water Quality	Check items listed in #1 and #2		
	Bypass valve open	Close bypass valve.	
	Channeling	Check for too slow or high service flow. Check for media fouling.	
	Lack of aeration in water	Program valve to draw air more frequently	
		Increase number of minutes in air draw cycle	
Clean injection assembly and screen			
4. Loss of Water Pressure	Fouled media	Clean media. Pretreat to prevent.	
	Improper backwash setting	Backwash more frequently	
5. Continuous Flow To Drain	Foreign material in control	Call dealer. Clean valve and replace pistons and seals.	
	Internal control leak	Same as above.	
	Valve jammed in backwash or rapid rinse position	Same as above.	
	Motor stopped or jammed	Check for jammed piston. Replace piston and seals. Replace motor if motor is unresponsive.	

Control Valve Error Code Diagnosis

Under normal operating conditions, when your control valve is in the “in service” position, the display should alternate between the current time of day and the number of days remaining (for filters and time clock softeners) or gallons remaining (for metered softeners) until the next regeneration. This is the “home display.” If the valve is currently going through a regeneration cycle, the display will show the cycle step on the left side of the display and the number of minutes remaining in that step on the right side of the display. If any other information is being displayed, then the valve is informing you of an issue. There are five error codes which could indicate an issue with the control valve. When an error is being displayed, the valve will be in a stopped position, and the buttons will not respond to being pressed. Even if the cause of the error code is corrected, the error code will not clear until the power supply has been disconnected and reconnected (this will be referred to as “cycling” the power). All error codes are displayed as the letters “Err” followed by a flashing number 2-6:

Error 2 - Valve is searching for homing slot.

Allow valve to continue running. If the homing slot is found, the valve will return to the home display, otherwise, another error code will appear.

Error 3 - No encoder slots are being seen.

This occurs when the motor is running, but the encoder is not seeing any of the slots in the encoder wheel. This can happen if the encoder has been disconnected, but most commonly occurs when debris in the valve body has stopped the piston, causing the encoder wheel to be unable to turn.

1. Check encoder connection. If the encoder is plugged in and snapped into place, skip to step #2 below. If encoder is disconnected, reconnect it and cycle power to clear the error.
2. Disconnect powerhead from valve body, cycle power to clear the error code. Manually cycle the power head through the regeneration cycle steps to verify that the motor can cycle properly while the powerhead is disconnected from the valve body. If the error 3 does not reappear, skip to step #3 below. If the error 3 does reappear, order a board & motor kit to replace the circuit board & motor.
3. Remove piston and seals from the valve body and inspect valve body for debris. Replace the seal & spacer kit. Inspect piston and replace piston if Teflon coating is worn

Error 4 - Unable to find homing slot.

1. Check encoder wheel for debris.
2. Cycle power. Valve should either find home or go to a different error code. If error 4 returns, replace powerhead assembly.

Error 5 - Motor overload.

This occurs when the motor current is too high. This could be caused by an issue with the motor itself, but is typically caused by friction in the valve body

1. Disconnect powerhead from valve body and cycle power to clear the error code.
2. If the error 5 returns, replace the motor. Otherwise, manually cycle the powerhead through the regeneration cycle steps to verify that the motor can cycle properly while the powerhead is disconnected from the valve body. Either way, proceed to the next step.
3. Remove piston and seals from the valve body and inspect valve body for debris. Replace the seal & spacer kit. Inspect piston and replace piston if Teflon coating is worn.

Error 6 - No motor current, or **Error Code 7** - No Twedo motor current.

This typically occurs if the motor cable has come unplugged from the circuit board. Check that the motor cable is plugged into the circuit board and attached to the motor. If this is not the issue, the motor or circuit board may need to be replaced.

No Display

If your display is blank, there is no power going to the circuit board due to one of the following factors:

- The electrical outlet is not powered or is switched off
- The power cable has come unplugged from the circuit board
- The power supply has come unplugged from your electrical outlet
- The power supply has come unplugged from the control valve
- The power supply is not working

This Warranty cannot be transferred – it is extended only to the original Purchaser or First User of the Product. By accepting and keeping this Product you agree to all of the warranty terms and limitations of liability described below.

IMPORTANT WARNING – READ CAREFULLY THE WATER SOFT WATER TREATMENT EQUIPMENT INSTALLATION, OPERATING AND MAINTENANCE INSTRUCTIONS MANUAL

to avoid serious personal injury and property HAZARDS and to ensure safe use and proper care of this product.

MODEL NUMBERS COVERED

Water Softeners, Media Filters, UpFlow Filters, Provectrs, UV, RO, Filters, Chemical Feed

WHAT IS COVERED BY THIS WARRANTY

WATERSOFT LLC (“WATER SOFT”) warrants that at the time of manufacture, the water treatment equipment shall be free from defects in material and workmanship as follows:

Thermoplastic Mineral Tanks	10 yrs.
Softener/Filter Control Valves	7 yrs.
Brine Tank Assemblies.....	5 yrs.
Reverse Osmosis System.....	5 yrs.
Other Accessories & Parts.....	1 yr

* This warranty does not include media and/or cartridge filter elements.

ADDITIONAL TERMS & CONDITIONS

What WATERSOFT Will Do If You Have a Covered Warranty Claim

WATERSOFT will at its option either make repairs to correct any defect in material or workmanship or supply and ship either new or used replacement parts or products. WATERSOFT will not accept any claims for labor or other costs.

Additional Exclusions and Limitations

This Warranty is non-transferable and does not cover any failure or problem unless it was caused solely by a defect in material or workmanship. In addition, this Warranty shall not apply:

- If the water treatment equipment is not correctly installed, operated, repaired and maintained as described in the INSTALLATION, OPERATING & MAINTENANCE INSTRUCTION Manual provided with the Product;
- If the tank is not the size indicated for the supply line size of the installation, as described in the Manual.
- If the unit has not always been operated within the factory calibrated temperature limits, and at a water pressure not exceeding 150 psi.
- To any failure or malfunction resulting from abuse (including freezing), improper or negligent: handling, shipping (by anyone other than WATER SOFT), storage, use, operation, accident; or alteration, lightning, flooding or other environmental conditions;
- To any failure or malfunction resulting from failure to keep the unit full of potable water, free to circulate at all times; and with the tank free of damaging water sediment or scale deposits;

- This Warranty does not cover labor costs, shipping charges, service charges, delivery expenses, property damage, administrative fees or any costs incurred by the purchaser in removing or reinstalling the water treatment equipment.
- The Warranty does not cover any claims submitted to WATERSOFT more than 30 days after expiration of the applicable warranty time period described in this Warranty, and does not apply unless prompt notice of any claim is given to an authorized WATERSOFT distributor or to WATERSOFT and WATERSOFT or a designated contractor is provided access to the installation and to the water treatment equipment.

THESE WARRANTIES ARE GIVEN IN LIEU OF ALL OTHER EXPRESS

WARRANTIES. NO WATERSOFT REPRESENTATIVE OR ANY OTHER PARTY IS AUTHORIZED TO MAKE ANY WARRANTY OTHER THAN THOSE EXPRESSLY CONTAINED IN THIS WARRANTY AGREEMENT.

ADDITIONAL WARRANTY LIMITATIONS

ANY IMPLIED WARRANTIES THE PURCHASER MAY HAVE, INCLUDING THE IMPLIED WARRANTIES OF MERCHANTABILITY AND FITNESS FOR A PARTICULAR PURPOSE, SHALL NOT EXTEND BEYOND THE APPLICABLE TIME PERIODS SPECIFIED ABOVE. Some states do not allow limitations on how long an implied Warranty lasts, so the above limitation may not apply to you.

LIMITATIONS OF REMEDIES

THE REMEDIES CONTAINED IN THIS WARRANTY ARE THE PURCHASER’S EXCLUSIVE REMEDIES. IN NO CIRCUMSTANCES WILL WATERSOFT OR THE SELLER OF THE PRODUCT BE LIABLE FOR MORE THAN, AND PURCHASER-USER’S REMEDIES SHALL NOT EXCEED, THE PRICE PAID FOR THE PRODUCT. IN NO CASE SHALL WATERSOFT OR SELLER BE LIABLE FOR ANY SPECIAL, INCIDENTAL, CONTINGENT OR CONSEQUENTIAL DAMAGES. Special, incidental, contingent and consequential damages for which WATERSOFT is not liable include, but are not limited to, inconvenience, loss or damage to property, consequential mold damage, loss of profits, loss of savings or revenue, loss of use of the products or any associated equipment, facilities, buildings or services, downtime, and the claims of third parties including customers. Some states do not allow the exclusion or the limitation of incidental or consequential damages, so the above limitation or exclusion may not apply to you.

WHAT TO DO IF YOU HAVE A PROBLEM COVERED BY THIS WARRANTY

Any Warranty coverage must be authorized by WATERSOFT. Contact the person from whom you purchased the Product, who must receive authorization from an WATERSOFT distributor or WATERSOFT. If you do not receive a prompt response, call WATERSOFT directly at 800-462-3790. Notice of a Warranty claim relating to replacement parts or products should be submitted by the authorized distributor to WATER SOFT at the following address:

WaterSoft, 710 Orange Street, Ashland, OH 44805

If your Product is new and not used and you wish to return it, contact your WATERSOFT distributor.





710 Orange Street, Ashland, OH 44805
PH 419.289.1500 FAX 419.289.1515
www.watersoftinc.com

0622TV