

LF120-S US - Damper Actuator

On/Off, Spring Return, 120 VAC, Auxiliary Switch



Technical Data	
Power Supply	120 VAC \pm 10%, 50/60 Hz
Power Consumption Running	5.5 W
Power Consumption Holding	3.5 W
Transformer Sizing	7.5 VA
Shaft Diameter	3/8" to 1/2" round, centers on 1/2"
Electrical Connection	(2) 3ft [1m], 18 GA appliance cables with 1/2" conduit connectors
Overload Protection	electronic throughout 0° to 95° rotation
Electrical Protection	actuators are double insulated
Angle of Rotation	Max. 95°
Torque	35 in-lbs [4 Nm] minimum
Direction of Rotation (Motor)	reversible with CW/CCW mounting
Direction of Rotation (Fail-Safe)	reversible with CW/CCW mounting
Position Indication	visual indicator, 0° to 95° (0° is full spring return position)
Running Time (Motor)	<40 to 75 sec
Running Time (Fail-Safe)	<25 sec @ -4°F to 122°F [-20°C to 50°C], < 60 sec @ -22°F [-30°C]
Humidity	max. 95% RH non-condensing
Ambient Temperature Range	-22°F to 122°F [-30°C to 50°C]
Storage Temperature Range	-40°F to 176°F [-40°C to 80°C]
Housing	NEMA 2, IP54
Housing Material	zinc coated steel
Agency Listings†	cULus acc. To UL 873 and CAN/CSA C22.2 No. 24-93
Noise Level (Motor)	<50 dB (A)
Noise Level (Fail-Safe)	<62 dB (A)
Servicing	maintenance free
Quality Standard	ISO 9001
Weight	3.3 lb [1.5 kg]
Auxiliary Switch	1 x SPDT, 3A resistive (0.5A inductive) @ 250 VAC, adjustable 0° to 95°

†Rated Impulse Voltage 4kV, Type of Action 1.AA.B, Control Pollution Degree 3.

Torque min. 35 in-lb, for control of air dampers.

Application

For On/Off, fail-safe control of dampers in HVAC systems. Actuator sizing should be done in accordance with the damper manufacturer's specifications. Control is On/Off from an auxiliary contact or a manual switch. The actuator is mounted directly to a damper shaft from 3/8" up to 1/2" in diameter by means of its universal clamp, 1/2" shaft centered at delivery. For shafts up to 3/4" use K6-1 accessory. A crank arm and several mounting brackets are available for applications where the actuator cannot be direct coupled to the damper shaft.

Operation

The LF series actuators provide true spring return operation for reliable fail-safe application and positive close off on air tight dampers. The spring return system provides consistent torque to the damper with, and without, power applied to the actuator. The LF series provides 95° of rotation and is provided with a graduated position indicator showing 0° to 95°. The actuator may be stalled anywhere in its normal rotation without the need of mechanical end switches. Power consumption is reduced in holding mode. The actuator is double insulated so an electrical ground connection is not necessary. The LF120-S US version are provided with one built-in auxiliary switch. This SPDT switch is provided for safety interfacing or signaling, for example, for fan start-up. The switching function is adjustable between 0° and 95°.

Dimensions (Inches[mm])

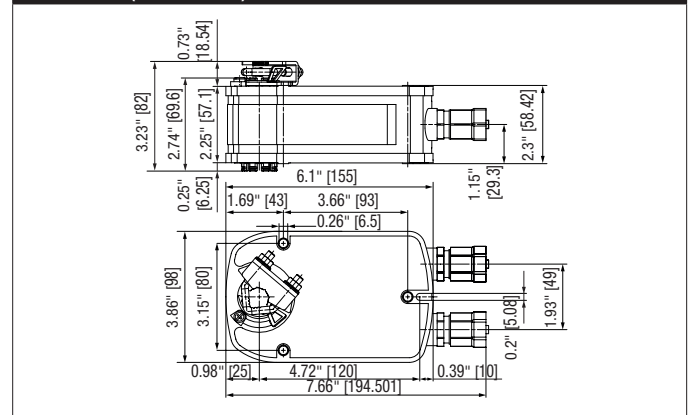

Accessories	
AV6-20	6.7" shaft extension for 1/4" to 3/4" diameter shafts.
IND-LF	LF position indicator.
K6 US	Standard LF clamp (3/8" to 1/2").
K6-1	LF clamp (1/2" to 3/4").
KG10A	Ball joint for 3/8" diameter rod, zinc plated.
KG6	Ball joint for 5/16" diameter rod, zinc plated.
KG8	Ball joint for 5/16" diameter rod, 90°, galvanized steel.
KH12	Univ. crankarm, slot 21/64" w, for 3/4" to 1" dia. shafts.
KH6	Univ. crankarm, slot 1/4" w, for 3/8" to 11/16" dia. shafts.
KH8	Univ. crankarm, slot 21/64" w, for 3/8" to 11/16" dia. shafts.
KH-LF	LF crankarm (with 1/2" diameter shaft pass through).
KH-LFV	V-bolt Kit for KH-LF.
LF-P	Anti-rotation bracket LF.
SH10	Push rod for KG10A ball joint (36" L, 3/8" diameter).
SH8	Push rod for KG6 & KG8 ball joints (36" L, 5/16" diameter).
TOOL-06	8 mm and 10 mm wrench.
ZDB-LF	Angle of rotation Limiter for LF.
ZF8-LF	8x8 mm form fit adaptor for LF.
ZG-109	Right angle bracket for ZS-260.
ZG-110	Stand-off bracket for ZS-260.
ZG-112	LF right angle bracket (4-1/2" H x 5-1/2" W x 2-1/2" D).
ZG-DC1	Damper clip for damper blade, 3.5" width.
ZG-DC2	Damper clip for damper blade, 6" width.
ZG-LF112	LF crankarm adaptor kit (includes ZG-112).
ZG-LF2	LF crankarm adaptor kit (T bracket included).
ZG-LMSA-1	Shaft extension for 3/8" diameter shafts (4" L).
ZG-LMSA-1/2-5	Shaft extension for 1/2" diameter shafts (5" L).
ZS-100	Weather shield - galvaneal (13" L x 8" W x 6" D).
ZS-101	Base plate for ZS-100.
ZS-150	Weather shield - PC w/ foam seal (16" L x 8-3/8" W x 4" D).
ZS-260	Explosion proof housing.
ZS-300	NEMA 4X, 304 stainless steel enclosure.
ZS-300-5	NEMA 4X, 316L stainless steel enclosure.
ZS-300-C1	1/2" shaft adaptor, standard with ZS-300(-5).
ZS-300-C2	3/4" shaft adaptor for ZS-300(-5).
ZS-300-C3	1" shaft adaptor for ZS-300(-5).
PS-100	Actuator power supply and control simulator.
ZG-CBLS	Electrical junction box for LF.

Typical Specification

On/Off spring return damper actuators shall be direct coupled type which require no crank arm and linkage and be capable of direct mounting to a shaft up to a 3/4" diameter and center on a 1/2" shaft (default). Actuator shall deliver a minimum output torque of 35 in-lbs. The actuator must be designed so that they may be used for either clockwise or counter clockwise failsafe operation. Actuators shall be protected from overload at all angles of rotation. If required, one SPDT auxiliary switch shall be provided with one switch having the capability of being adjustable. Actuators with auxiliary switch must be constructed to meet the requirement for Double Insulation so an electrical ground connection is not required to meet agency listings. Actuators shall be cULus listed, have a 5 year warranty, and be manufactured under ISO 9001 International Quality Control Standards. Actuators shall be as manufactured by Belimo.

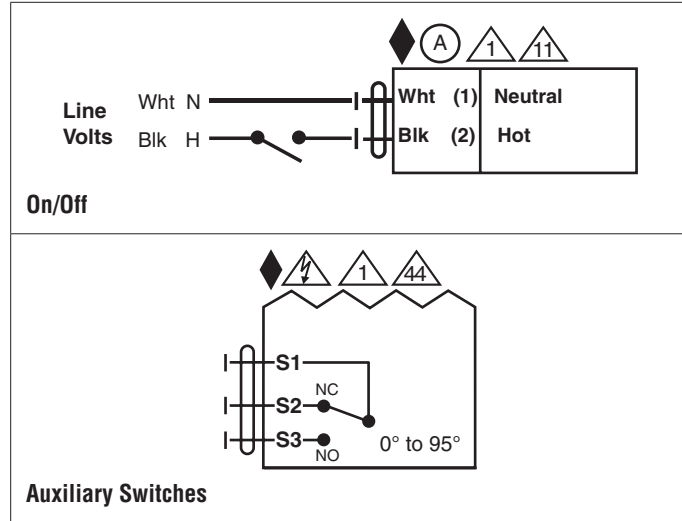

LF120-S US - Damper Actuator

On/Off, Spring Return, 120 VAC, Auxiliary Switch

Wiring Diagrams



WARNING! LIVE ELECTRICAL COMPONENTS!

During installation, testing, servicing and troubleshooting of this product, it may be necessary to work with live electrical components. Have a qualified licensed electrician or other individual who has been properly trained in handling live electrical components perform these tasks. Failure to follow all electrical safety precautions when exposed to live electrical components could result in death or serious injury.



Meets cULus requirements without the need of an electrical ground connection.



Apply only AC line voltage or only UL-Class 2 voltage to the terminals of auxiliary switches. Mixed or combined operation of line voltage/safety extra low voltage is not allowed.



Actuators with appliance cables are numbered.



Provide overload protection and disconnect as required.



Actuators may be connected in parallel if not mechanically linked. Power consumption and input impedance must be observed.



One built-in auxiliary switch (1x SPDT), for end position indication, interlock control, fan startup, etc.