

# INSTALLATION AND MAINTENANCE INSTRUCTIONS

## NP16HV SERIES UNITS

### RESIDENTIAL PACKAGED UNITS

Heat Pumps  
507635G04  
03/2022

THIS MANUAL MUST BE LEFT WITH THE HOMEOWNER FOR FUTURE REFERENCE

### Table of Contents

Unit Dimensions .....	2
Roof Curb Dimensions .....	4
Adjustable Roof Curb Dimensions.....	6
Installation .....	9
Electrical Wiring.....	11
Duct System .....	12
Condensate Drain.....	12
Sequence of Operation.....	14
Defrost System.....	15
System Performance .....	17
Maintenance .....	17
Wiring Diagrams.....	20

#### **⚠ WARNING**

Installation and servicing of air conditioning equipment can be hazardous due to internal refrigerant pressure and live electrical components. Only trained and qualified service personnel should install or service this equipment. Installation and service performed by unqualified persons can result in property damage, personal injury, or death.

#### **⚠ WARNING**

For your safety, do not store or use gasoline or other flammable vapors and liquids in the vicinity of this or any other appliance. Such actions could result in property damage, personal injury, or death.

**GE Appliances**  
**A Haier Company**  
Appliance Park  
Louisville, KY 40225



(P) 507635G04

#### **⚠ CAUTION**

The installation of this appliance must conform to the requirements of the National Fire Protection Association; the National Electrical Code, ANSI/NFPA No. 70 (latest edition) in the United States; the Canadian Electrical Code Part 1, CSA 22.1 (latest edition) in Canada; and any state or provincial laws or local ordinances. Local authorities having jurisdiction should be consulted before installation is made. Such applicable regulations or requirements take precedence over the general instructions in this manual.

**Save these instructions for future reference**

# Unit Dimensions - Small Base Air Conditioners & Heat Pumps

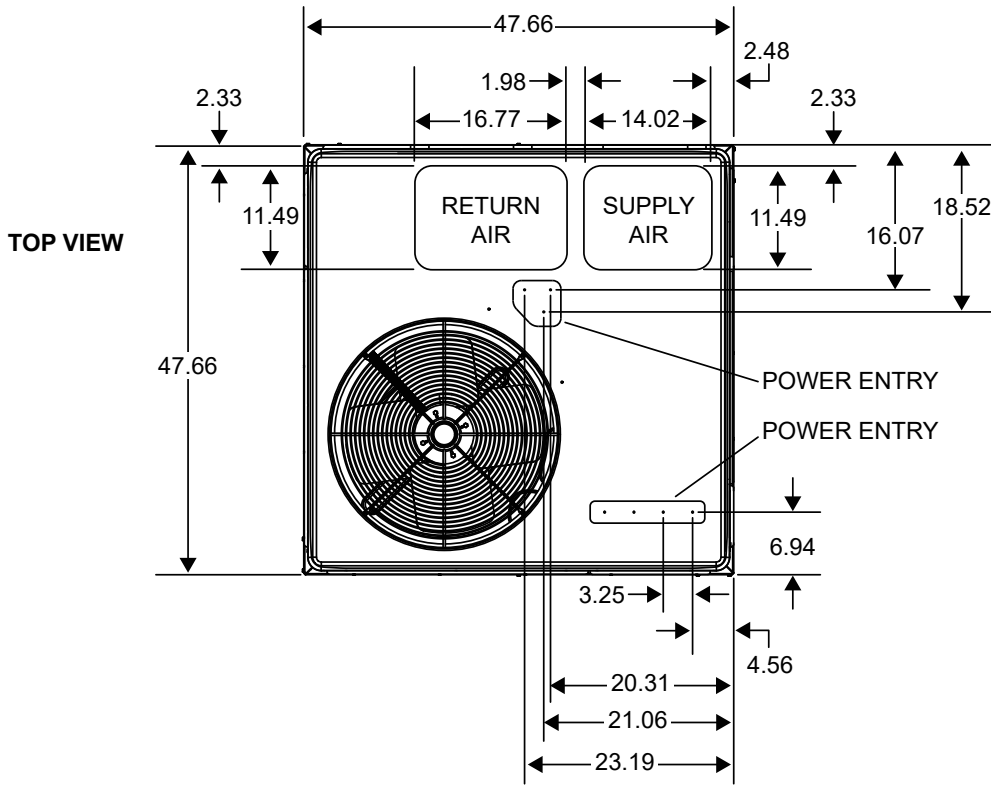

## SIDE VIEWS

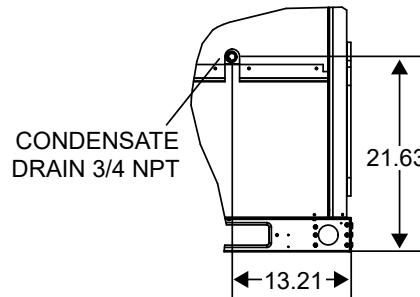
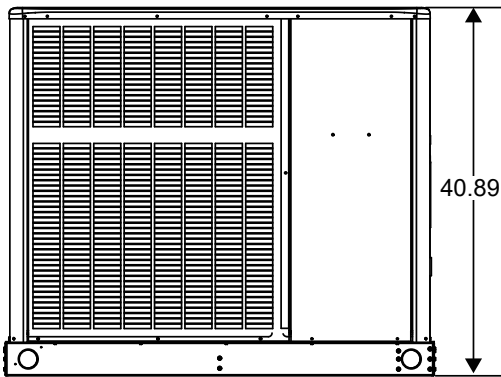

TYPICAL DRAIN LOCATION

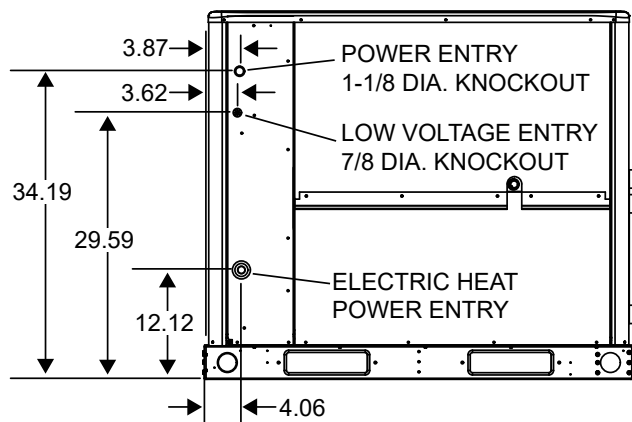
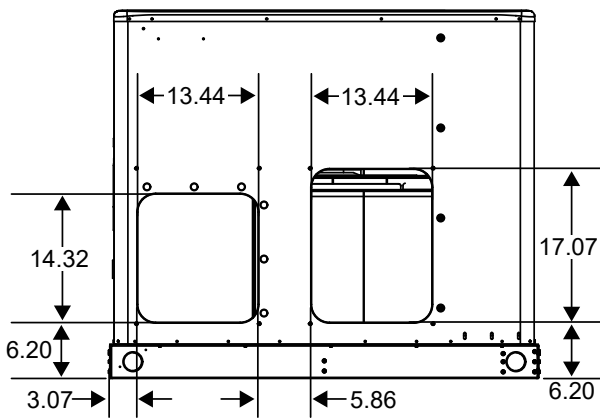

# Unit Dimensions - Large Base Air Conditioners & Heat Pumps

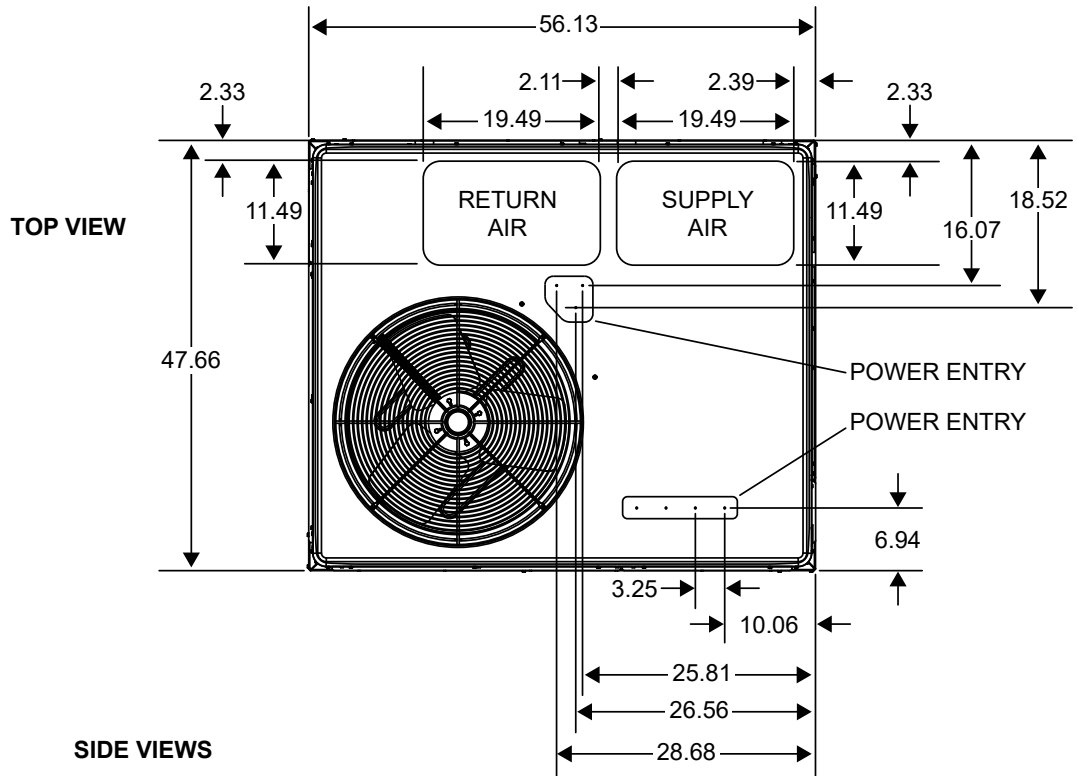

**SIDE VIEWS**

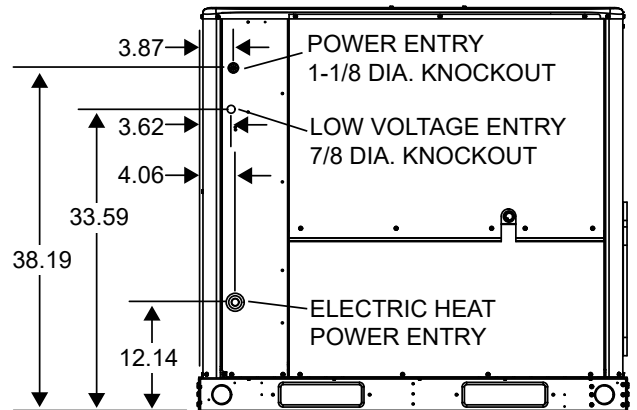
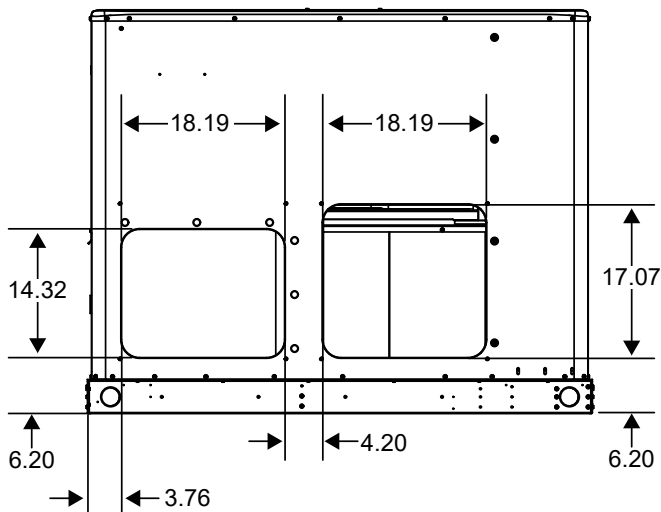
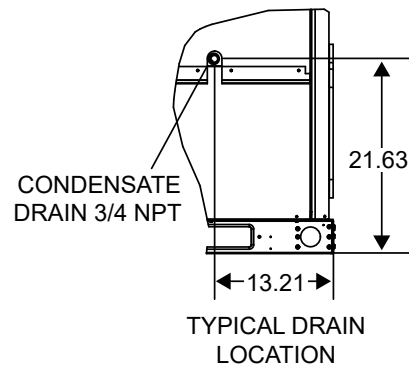
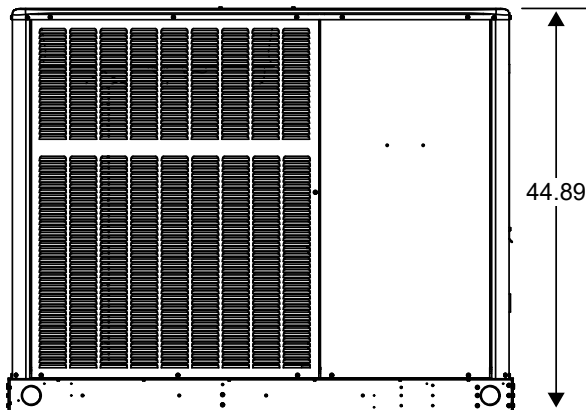

# Roof Curb Dimensions - Small Base Air Conditioners & Heat Pumps

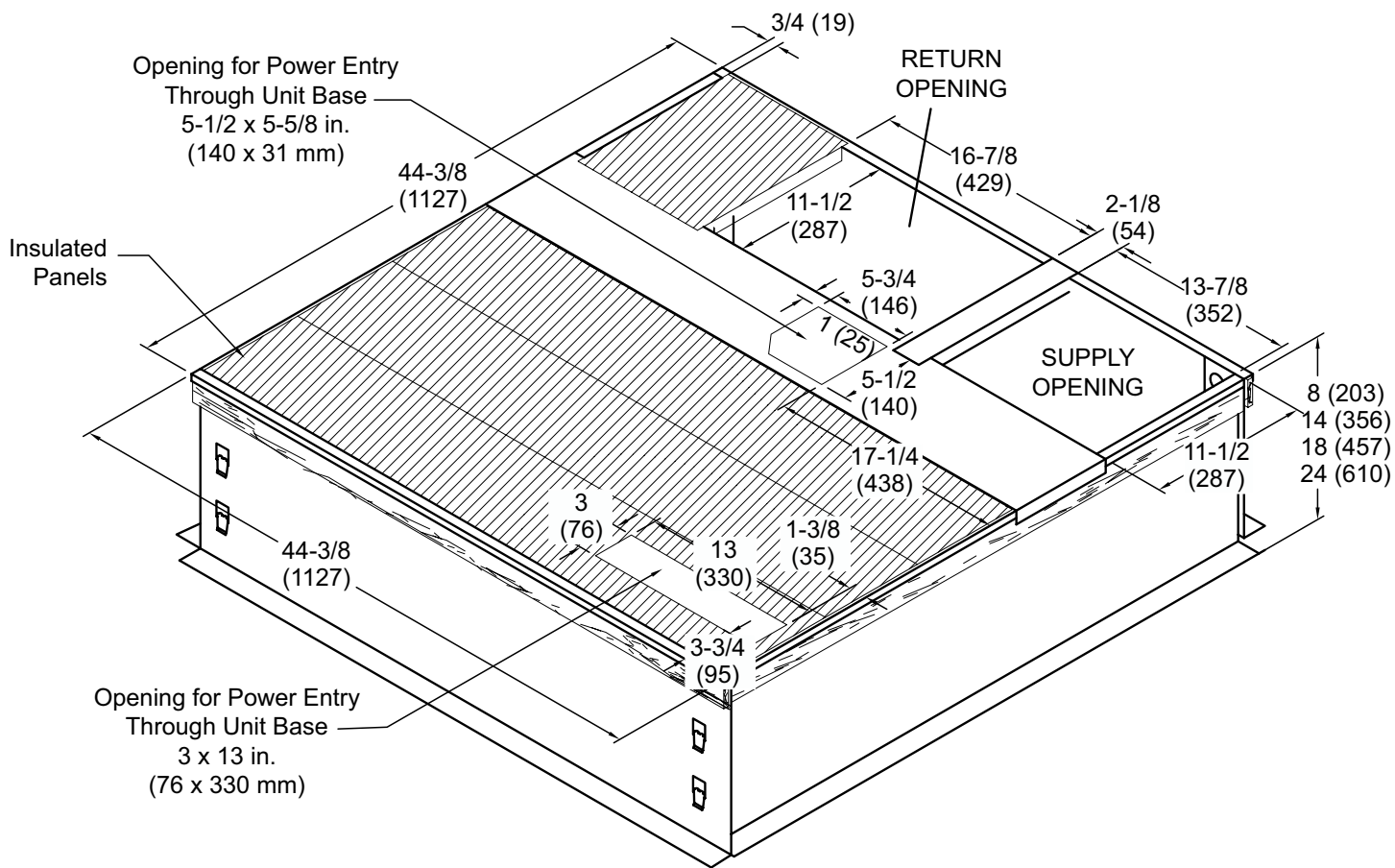

NOTE - Roof deck may be omitted within confines of curb.

# Roof Curb Dimensions - Large Base Air Conditioners & Heat Pumps

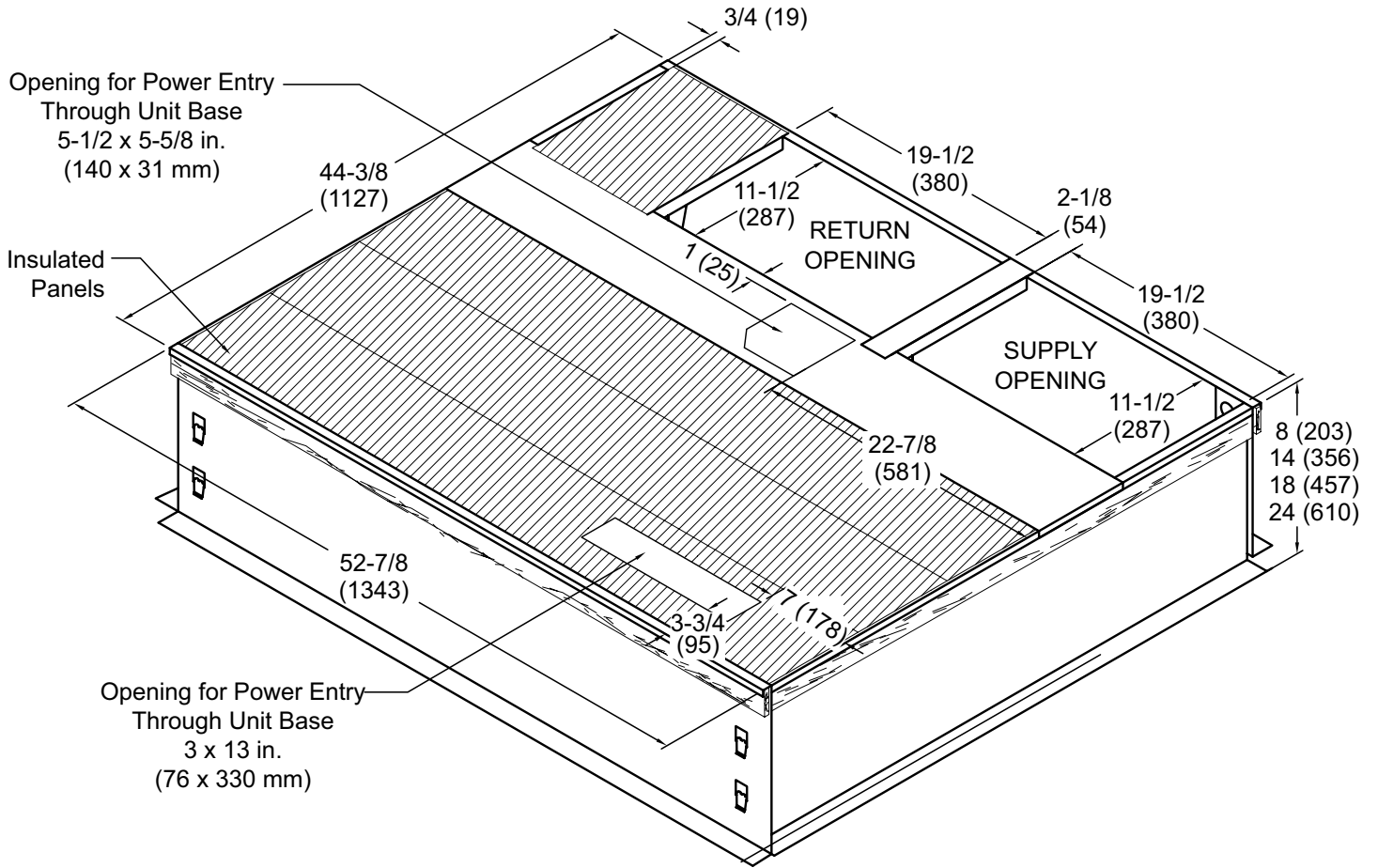

NOTE - Roof deck may be omitted within confines of curb.

# Adjustable Roof Curb Dimensions - Small Base Air Conditioners & Heat Pumps (Knock-Down Style)

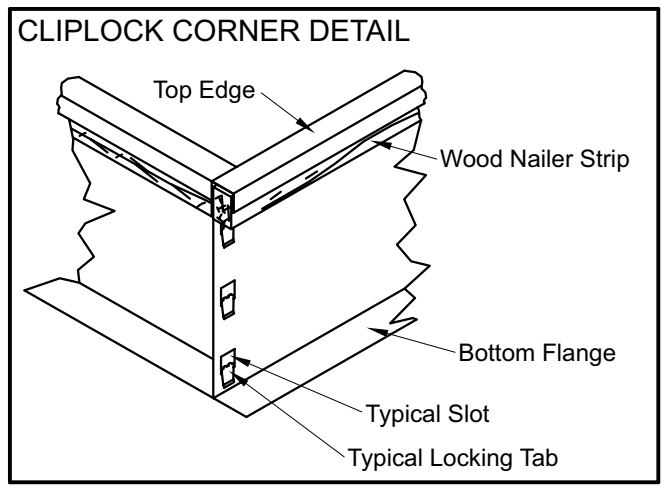

NOTE: See Cliplock 1000 installation instructions for complete assembly and installation procedures and requirements.

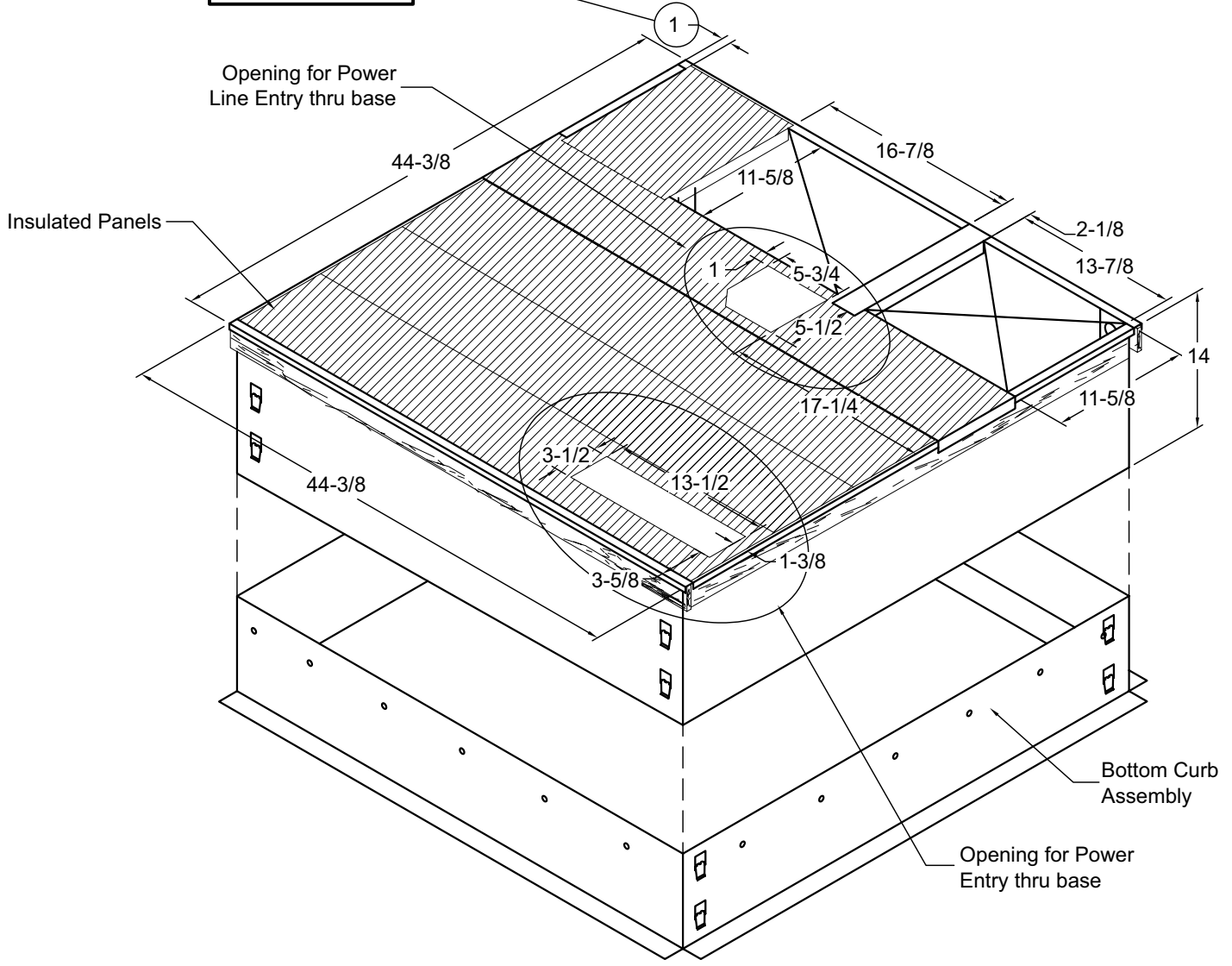
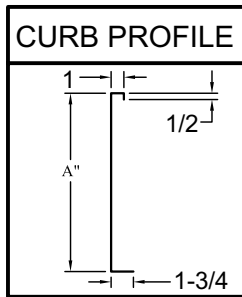

NOTE - Roof deck may be omitted within confines of curb.

# Adjustable Roof Curb Dimensions - Large Base Air Conditioners & Heat Pumps (Knock-Down Style)

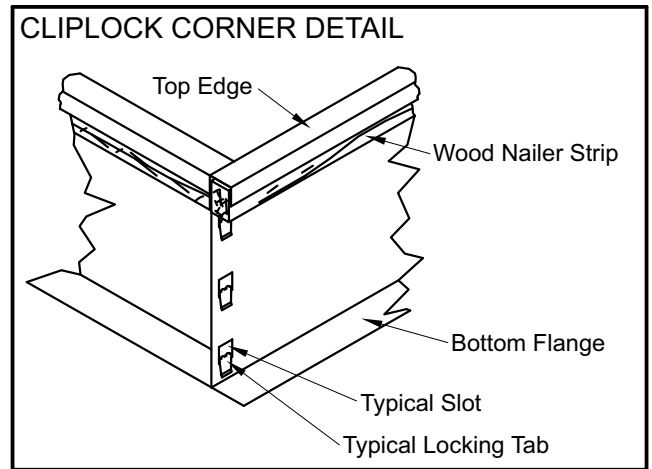

NOTE: See Cliplock 1000 installation instructions for complete assembly and installation procedures and requirements.

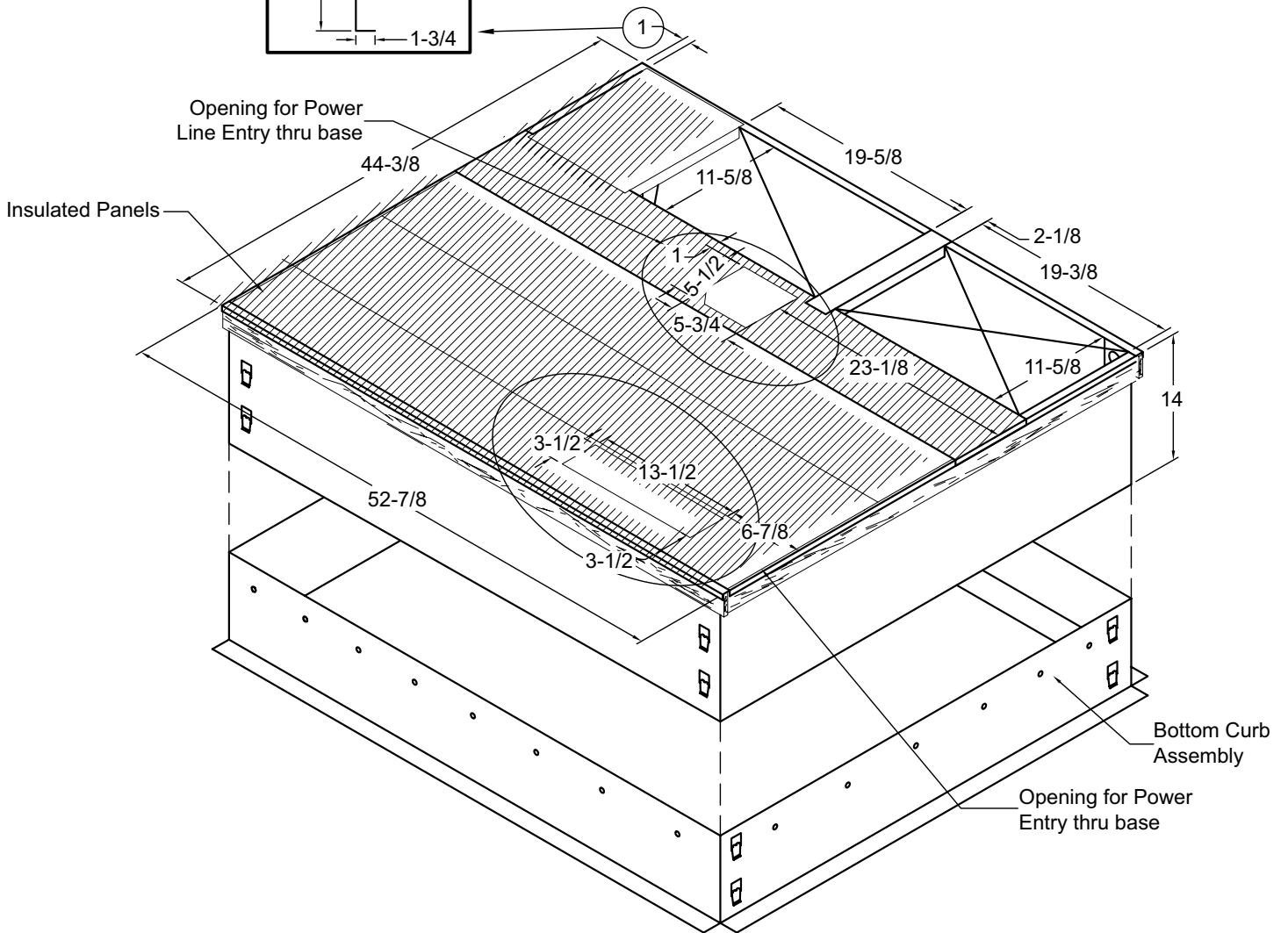
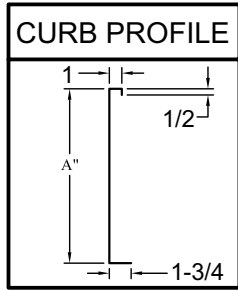

NOTE - Roof deck may be omitted within confines of curb.

## Adjustable Roof Curb Dimensions - Air Conditioners & Heat Pumps (Welded Style)

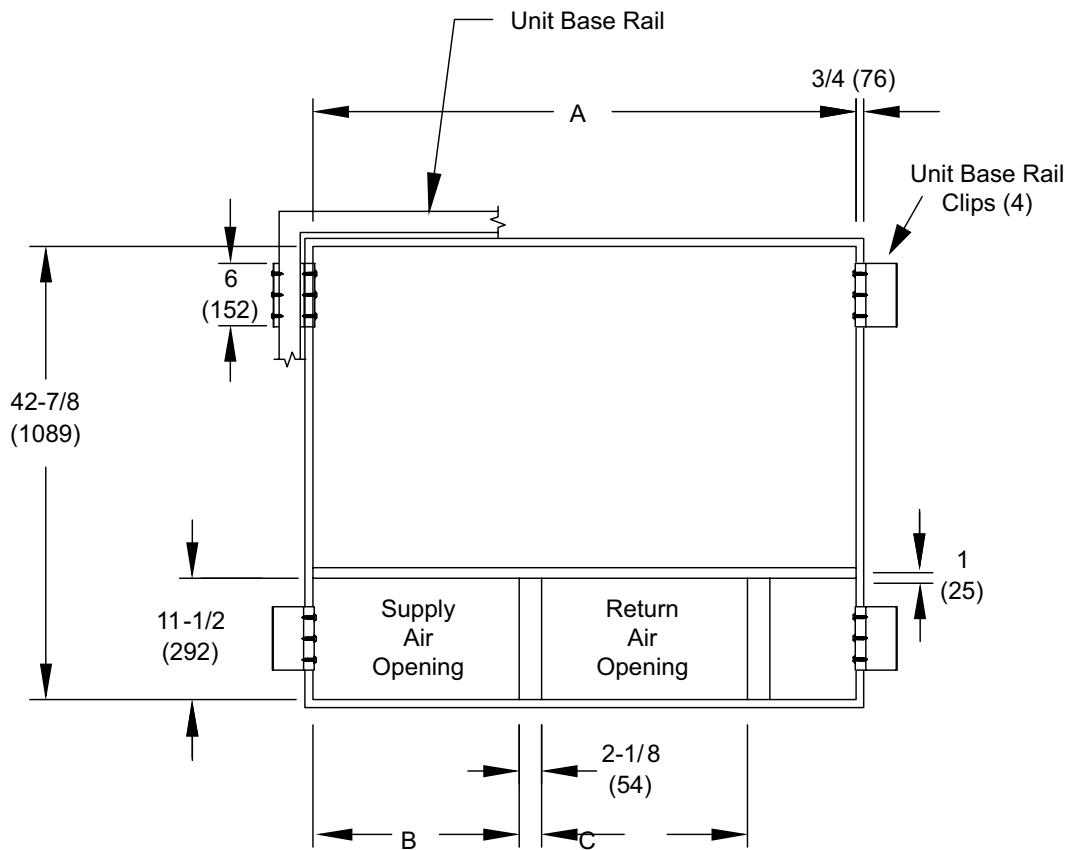
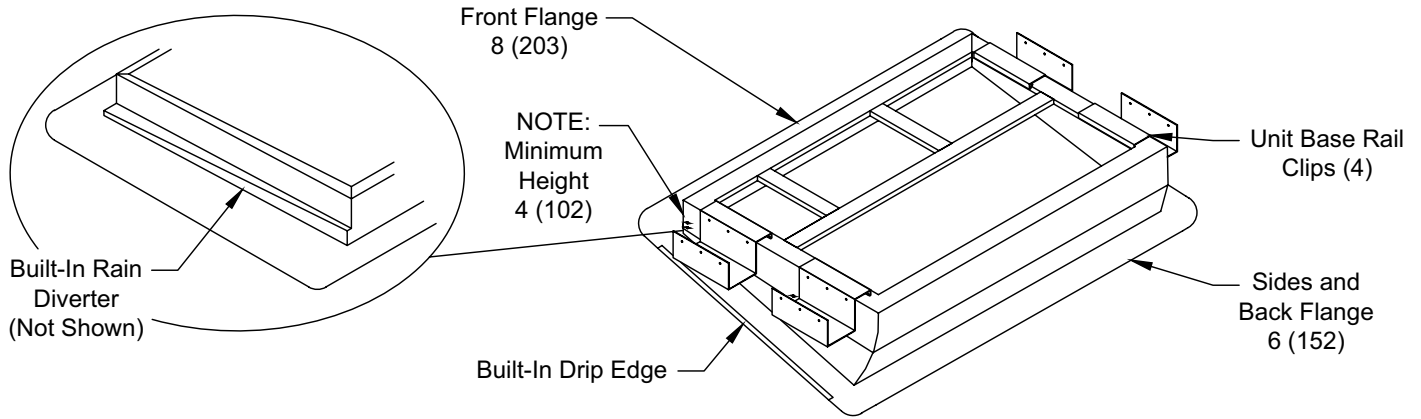

Usage	A		B		C	
	in.	mm	in.	mm	in.	mm
24,30,36	42-7/8	1089	13-7/8	352	16-7/8	429
42,48,60	51-3/8	1305	19-1/2	495	19-1/2	495

## **WARNING**

Improper installation, adjustment, alteration, service, or maintenance can cause injury or property damage. Refer to this manual. For assistance or additional information, consult a qualified installer or service agency.

## **Installation**

These instructions explain the recommended method of installation of the packaged heat pump and/or air conditioner units and associated electrical wiring.

This unit is designed and approved for use as a self-contained air-to-air outdoor heat pump and air conditioner system.

The units are factory-equipped with a transformer and blower control for applications without auxiliary heat. Electric heat accessory kits (PHK-) can be ordered for field installation of additional heat where required.

These instructions, and any instructions packaged with mating components and/or accessories, should be carefully read prior to beginning installation. Note particularly any **CAUTIONS** or **WARNINGS** in these instructions and all labels on the units.

These instructions are intended as a general guide only, for use by qualified personnel and do not supersede any national or local codes in any way. Compliance with all local, state, provincial, or national codes pertaining to this type of equipment should be determined prior to installation.

### **Inspection of Shipment**

Upon receipt of equipment, carefully inspect it for possible shipping damage. If damage is found, it should be noted on the carrier's freight bill. Take special care to examine the unit inside the carton if the carton is damaged. If damaged, file a claim with the transportation company.

If any damages are discovered and reported to the carrier, **DO NOT INSTALL THE UNIT, as claim may be denied.**

**Check the unit rating plate to confirm specifications are as ordered.**

### **Limitations**

The unit should be installed in accordance with all national and local safety codes.

Limitations of the unit and appropriate accessories must also be observed.

The unit must not be installed with any ductwork in the outdoor air stream. The outdoor fan is not designed to operate against any additional static pressure.

## **Location**

The unit is designed to be located outdoors with sufficient clearance for free entrance to the air inlet and discharge air openings. The location must also allow for adequate service access.

The unit must be installed on a solid foundation that will not settle or shift. Adequate structural support must be provided. Install the unit in level position. Isolate the base from the building structure to avoid possible transmission of sound or vibration into the conditioned space.

**The heat pump unit foundation should be raised to a minimum of 3" above finish grade.** In areas which have prolonged periods of temperature below freezing and snowfall, the heat pump unit should be elevated above the average snow line. Extra precaution should be taken to allow free drainage of condensate from defrost cycles to prevent ice accumulation. The unit should not be located near walkways, to prevent possible icing of surface from defrost condensate.

**Avoid placing the unit near quiet areas, such as sleeping quarters or study rooms.** Normal operating sound levels may be objectionable if the unit is placed near certain rooms.

**For improved start-up performance, the condenser coil should be washed with suitable detergent to remove any residue from manufacturing processes.**

## **Use of Unit During Construction**

Use of this unit as a construction heater or air conditioner is not recommended during any phase of construction. Very low return air temperatures, harmful vapors and operation of the unit with clogged or misplaced filters will damage the unit.

If this unit has been used for heating or cooling of buildings or structures under construction, the following conditions must be met or the warranty will be void:

- A room thermostat must control the unit. The use of fixed jumpers that will provide continuous heating or cooling is not allowed.
- A pre-filter must be installed at the entry to the return air duct.
- The return air duct must be provided and sealed to the unit.
- Return air temperature range between 55°F (13°C) and 80°F (27°C) must be maintained.
- Air filters must be replaced and pre-filters must be removed upon construction completion.
- The input rate and temperature rise must be set per the unit rating plate.
- The heat exchanger, components, duct system, air filters and evaporator coil must be thoroughly cleaned following final construction clean-up.

- The unit operating conditions (including airflow, cooling operation, ignition, input rate, temperature rise and venting) must be verified according to these installation instructions.

### Clearances

All units require certain clearances for proper operation and service. Refer to Table 1 for the minimum clearances to combustibles required for construction, servicing, and proper unit operation.

In the U.S., units may be installed on combustible floors made from wood or class A, B, or C roof covering material.

In Canada, units may be installed on combustible floors. Units must be installed outdoors.

**Do not permit overhanging structures or shrubs to obstruct condenser air discharge outlet.**

	Clearance to Combustibles	Clearance for Service Access
Front of unit	0 in.	24 in.
Back of unit	0 in.	0 in.
Left side	0 in.	24 in.
Right side	0 in.	24 in.
Base of unit	0 in.	0 in.
Top of unit	0 in.	48 in.

For any future service, installer must provide access to screws of top and rear panels.

**Table 1. Minimum Clearances**

### Compressor

Units are shipped with compressor mountings factory adjusted and ready for operation. Do not loosen compressor mounting bolts.

### Roof Curb Installation

If a roof curb is used, follow the manufacturer's installation instructions and be sure that all required clearances are observed (see Clearances section).

Prior to setting the unit on the roof curb, the shipping bracket located underneath the unit must be removed. Remove the two screws in the base rail (located on the front and rear sides of the unit). The four screws and the bracket can be discarded. See Figure 1.

### Rigging Unit

Exercise care when moving the unit. Do not remove any packaging until the unit is near the place of installation.

1. Connect rigging to the unit base rails using both holes in each corner.
2. All panels must be in place for rigging.
3. Place field-provided spreaders in place. Spreaders must be of adequate strength and length (must exceed unit dimension by 6 inches).

Units may also be moved or lifted with a forklift. **The lengths of the forks of the forklift must be a minimum of 42 inches.**

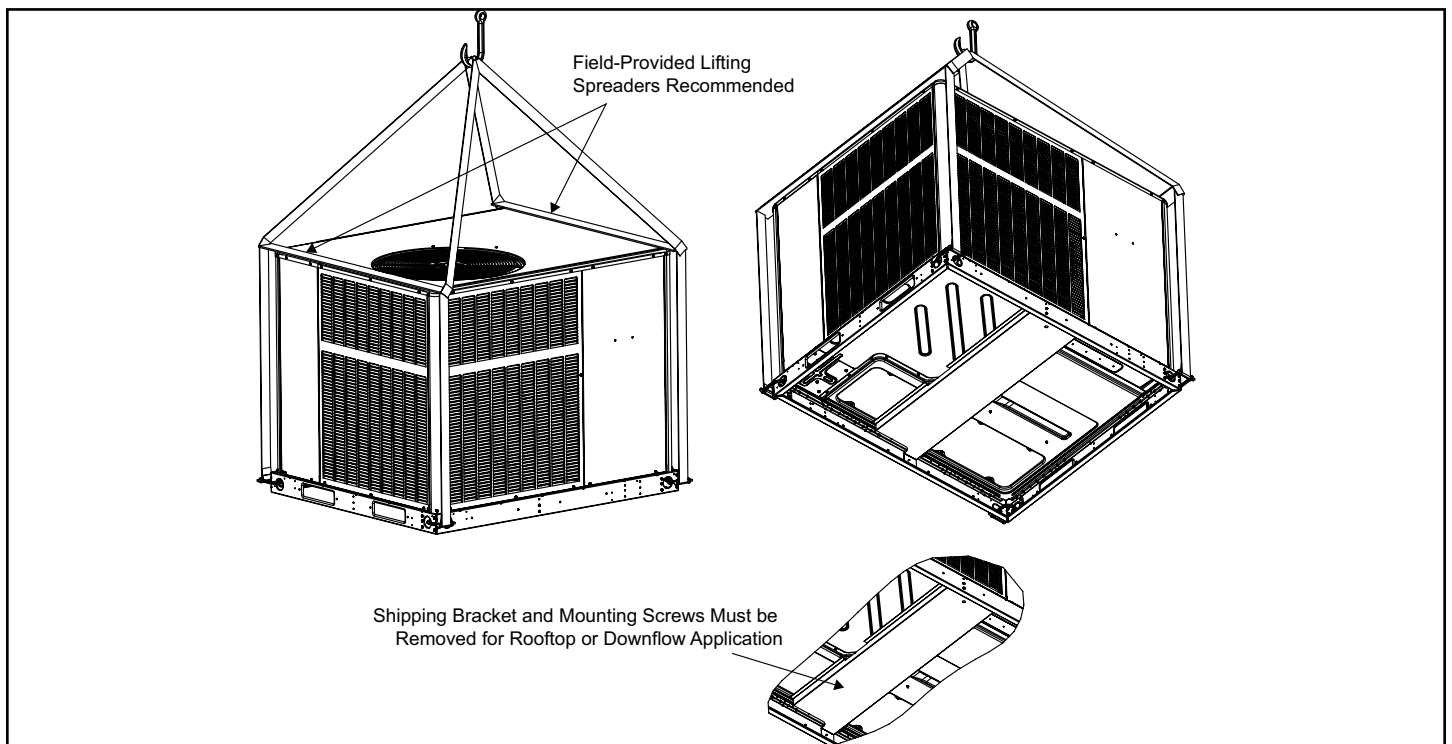

**Figure 1.**

## ⚠ CAUTION

Before lifting a unit, make sure that the weight is distributed equally on the cables so that it will lift evenly.

### Unpacking

Locate the four stacking brackets at each corner of the top panel. Remove the screws and washers that secure these brackets. All screws must be re-installed. The washers and stacking brackets can be discarded. Remove the bag and remaining packaging material, which can be discarded. Locate the four plastic fork slot bumpers on the base rails. Remove the fasteners and bumpers and discard.

## ⚠ CAUTION

As with any mechanical equipment, personal injury can result from contact with sharp sheet metal edges. Be careful when you handle this equipment.

### Service Access

Access to all serviceable components is provided by four removable panels: upper access panel (for blower, ID coil, and optional filter), Aux heat access, control access panel, and compressor access.

## ⚠ WARNING

This unit is charged with HFC-410A refrigerant. Operating pressures for units charged with HFC-410A are higher than pressures in units charged with HCFC-22. All service equipment **MUST** be rated for use with HFC-410A refrigerant.

## Electrical Wiring

All field wiring must be done in accordance with National Electrical Code recommendations, local codes, and applicable requirements of UL Standards, or in accordance with Canadian Electrical Code recommendations, local codes, or CSA Standards.

Power wiring, disconnect means, and over-current protection are to be supplied by the installer. Refer to the unit rating plate for maximum over-current protection and minimum circuit ampacity, as well as operating voltage. The power supply must be sized and protected according to specifications supplied.

The unit must be grounded with a separate ground conductor. See Figure 2 for typical field wiring connection. The wiring diagram can be found on the unit inside the access panel. Low voltage control wiring are terminal strip or pigtail leads located on the main control box and are

color-coded to match the connection called out on the wiring schematic.

**NOTE:** An optional bottom-entry power kit is available for these units. See the kit instructions for proper installation details.

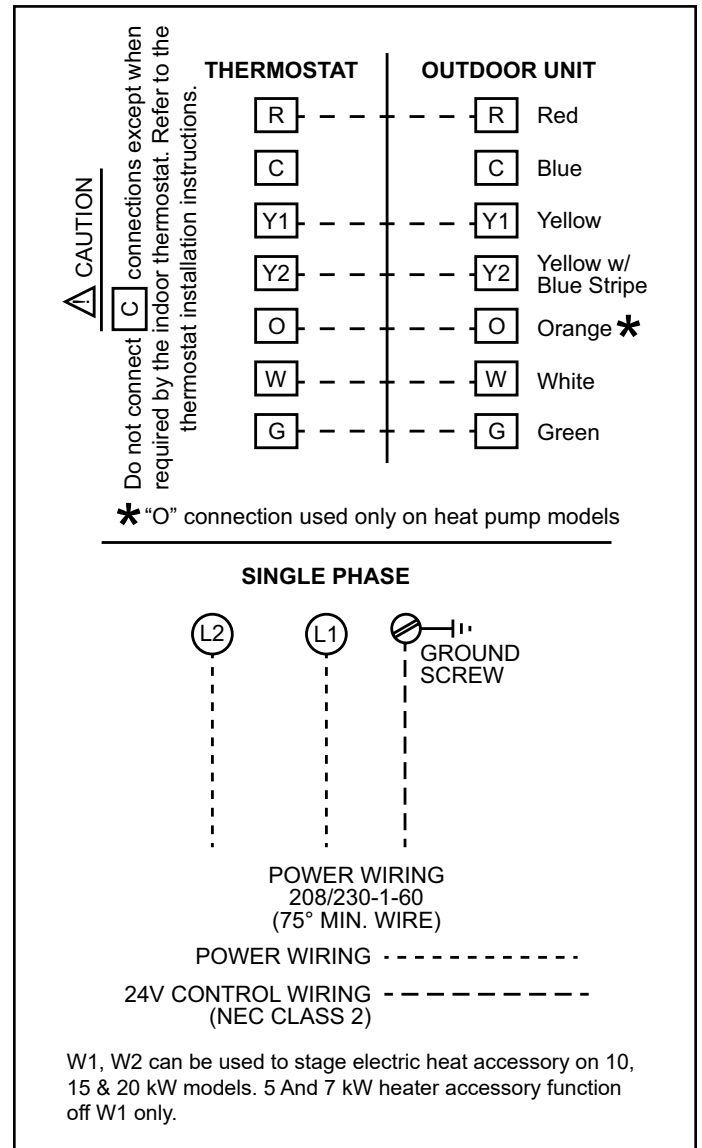

**Figure 2. Typical Wiring Connections**

## ⚠ CAUTION

When connecting electrical power and control wiring to the unit, waterproof-type connectors must be used so that water or moisture cannot be drawn into the unit during normal operation.

**Units are factory wired for a 230-volt power supply. If power supply is 208 volts, it will be necessary to change a wire connection on the unit transformer from 240V terminal to 208V terminal as shown on the wiring diagram.**

**Use only copper conductors.**

If any of the original unit wiring is replaced, the same size and type wire must be used.

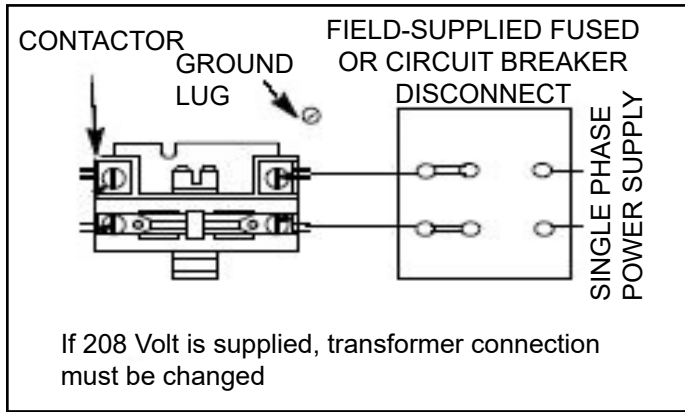

**Figure 3. 208 / 230 Line Voltage Wiring**

**Thermostat**

The room thermostat should be located on an inside wall where it will not be subject to drafts, sun exposure, or heat from electrical fixtures or appliances. Follow the manufacturer’s instructions enclosed with the thermostat for general installation procedure. Color-coded insulated wires (#18 AWG) should be used to connect the thermostat to the unit. A minimum of five wires are required for proper installation.

**Duct System**

The duct system should be designed and sized according to the methods in the Air Conditioning Contractors of America (ACCA) manual that is most appropriate to the installation application.

A closed return duct system shall be used. This shall not preclude use of economizers or outdoor fresh air intake. It is recommended that supply and return duct connections at the unit be made with flexible joints.

The supply and return air duct systems should be designed for the CFM and static requirements of the job. They should not be sized to match the dimensions of the duct connections on the unit.

The unit is shipped ready for horizontal flow (side duct connections) or downflow (bottom duct connections). All units are equipped with a drain pan overflow switch that is installed and wired at the factory. Duct attachment screws are intended to go into the duct panel flanges. Duct to unit connections must be sealed and weather proofed.

For horizontal duct systems:

1. Remove the duct covers on side of the unit. They can be discarded.
2. Install the duct system to the unit.

For downflow duct systems:

1. Remove the duct covers on side of the unit. Keep the screws and the covers as they will be re-installed later.
2. Remove the downflow duct covers located inside unit. Remove the four screws securing each cover. Remove the covers from the unit. They can be discarded.
3. Remove screws located between the supply and return air openings that attach the blower deck to the base pan. These screws can interfere with bottom duct connections or roof curb seals. Discard these screws.
4. Install the duct system to the unit.
5. Re-install the duct covers removed in Step 1.

**Filters**

Air filters are not supplied with the unit. A field-provided air filter must always be installed ahead of the evaporator coil and must be kept clean or replaced. Dirty filters will reduce the airflow of the unit.

An optional filter rack kit may be purchased separately for installation inside the unit’s coil compartment. Air filter sizes are shown in Table 2 for use with filter rack kit.

**NOTE:**

The filter rack must be installed prior to installation of the unit in applications where access to the rear panel is limited.

Unit Model	Filter 1	Filter 2
24,36	14 x 20 x 1	20 x 20 x 1
48,60	20 x 20 x 1	

**Table 2. Unit Air Filter Sizes - inches**

A Photocatalytic Oxidation (PCO) air purification system is available as a field-installed accessory for this product. A wiring harness for the installation of this accessory has been factory installed. If this accessory is going to be installed, it becomes critical that the system filter be installed ahead of this unit’s return. Therefore, see the PCO accessory for filter requirements, plan the installation of filter ahead of this unit, and **do not use the internal filter rack described above.**

**Condensate Drain**

**⚠ CAUTION**

Drain lines should be hand-tightened only. Do not use tools to tighten fitting into drain.

This package unit is equipped with a 3/4” FPT coupling for condensate line connection. Plumbing must conform

to local codes. Use a sealing compound on male pipe threads.

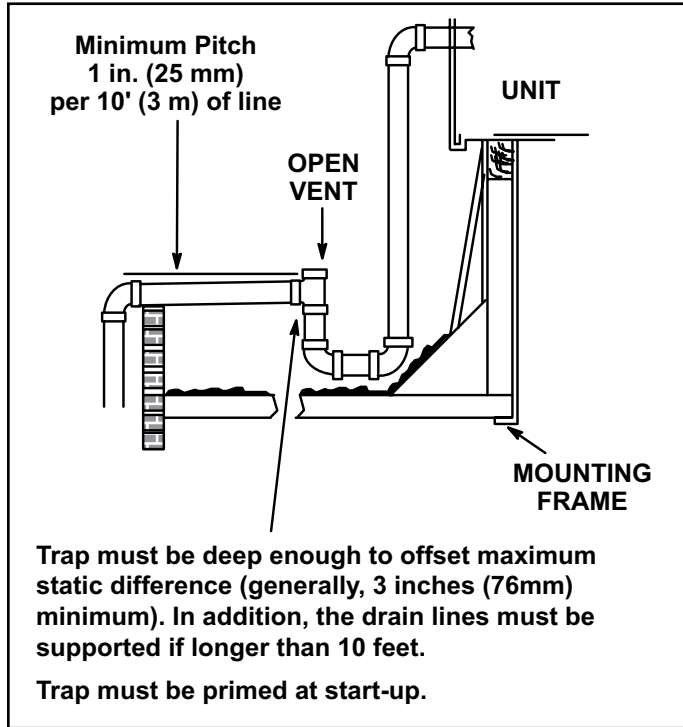

Figure 4. Typical Condensate Drain Connection

**Do not** operate unit without a drain trap. The condensate drain is on the negative pressure side of the blower; therefore, air being pulled through the condensate line will prevent positive drainage without a proper trap.

**The condensate drain line must be properly trapped, routed to a suitable drain and primed prior to unit commissioning.**

**NOTE:** Install drain lines and trap so they do not block service access to the unit.

See Figure 4 for proper drain arrangement. The drain line must pitch to an open drain or pump to prevent clogging of the line. Seal around the drain connection with suitable material to prevent air leakage into the return air system.

To prime trap, pour several quarts of water into drain, enough to fill drain trap and line.

### Crankcase Heater (if used)

Some models may be equipped with a crankcase heater to prevent excessive migration of liquid refrigerant into the compressor during off cycles. Power must be maintained to the unit to keep this feature active.

Except as required for safety while servicing, **do not open the system disconnect switch.**

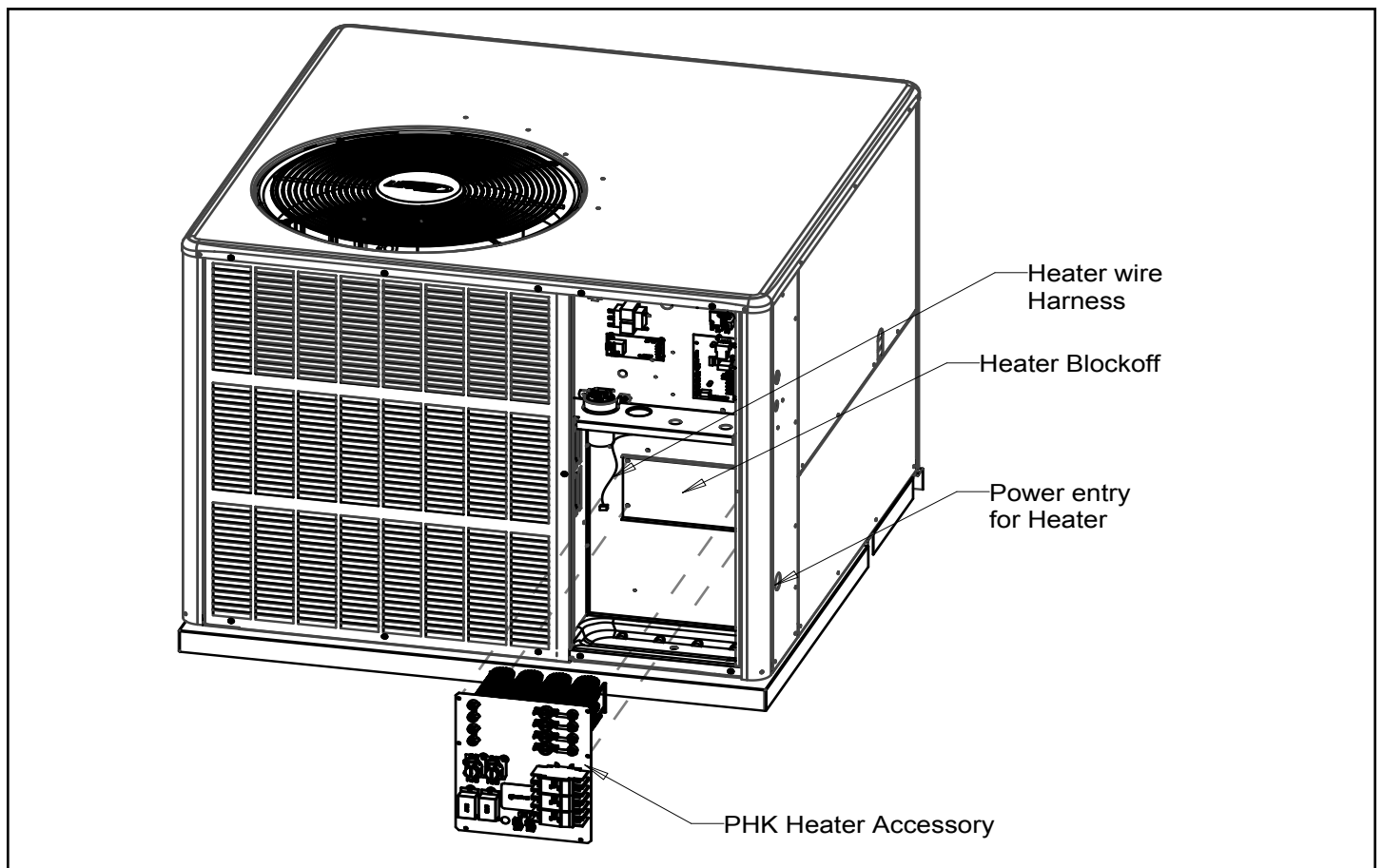

Figure 5.

## Heater Kit Accessory (if used)

The unit is fully equipped for operation without auxiliary heat. A heater kit accessory may also be used. To install the heater kit accessory (see Figure 5):

1. Disconnect the power and open the main control access.
2. Disconnect the plug separating the high voltage wire harness. Remove the high voltage wire harness plug and discard.
3. Remove the heater blockoff by removing the four screws holding it in place.
4. Insert the heater into the control panel and fasten in the same mounting holes.
5. Plug the heater wiring harness into the wire harness on the control assembly. Field wiring of the auxiliary heater is separate from the unit power supply. Wire the power supply wiring for the heater to the appropriate connections on the heater kit.

## Sequence of Operation

### Blower Control

Units are equipped with a variable speed motor that is capable of maintaining a specified CFM throughout the external static range. A particular CFM can be obtained by positioning jumpers (COOL, HEAT, and ADJUST) on the blower control. The HEAT and COOL jumpers are labeled A, B, C and D. Each of the numbers corresponds with an air volume (CFM) setting. The ADJUST jumper is labeled Test, -, +, and Norm. The + and - pin settings are used to add or subtract a percentage of the CFM selected. The Test jumper is used to operate the motor in the test mode. Figure 7 shows the blower control.

The **CFM LED** located on the blower control flashes one time per 100 cfm to indicate selected blower speed. For example, if the unit is operating at 1200 CFM, the CFM LED will flash 12 times. If the CFM is 1150, the CFM LED will flash 11 full times plus one fast or half flash. At times, the light may appear to flicker or glow. This takes

place when the control is communicating with the motor between cycles. This is normal operation. Read through the jumper settings section before adjusting the jumper to obtain the appropriate blower speed. To change jumper positions, gently pull the jumper off the pins and place it on the desired set of pins. The following section outlines the different jumper selections available and conditions associated with each one. Refer to Figure 7.

From the engineering handbook and/or specification sheet, determine which row most closely matches the desired CFM. Once a specific row has been chosen (+, NORMAL, or -), CFM volumes from other rows cannot be used. Below are descriptions of the jumper selections. The variable speed motor slowly ramps up to and down from the selected air flow during both cooling and heating demand. This minimizes noise and eliminates the initial blast of air when the blower is initially energized.

### ADJUST

The ADJUST pins allow the motor to run at normal speed, approximately 10 percent higher, or approximately 10 percent lower than normal speed.

The TEST pin is available to bypass the blower control and run the motor at approximately 70 percent to make sure that the motor is operational. This is used mainly in troubleshooting. The G terminal must be energized for the motor to run.

### COOL

The COOL jumper is used to determine the CFM during cooling operation. In AC units, this jumper selection is activated for cooling when Y1/Y2 is energized. In heat pump units, the selection is activated for cooling when Y1/Y2 and O are energized.

The blower motor runs at 80 percent of the selected air flow for the first 7-1/2 minutes of each cooling demand. This feature allows for greater humidity removal and saves energy.

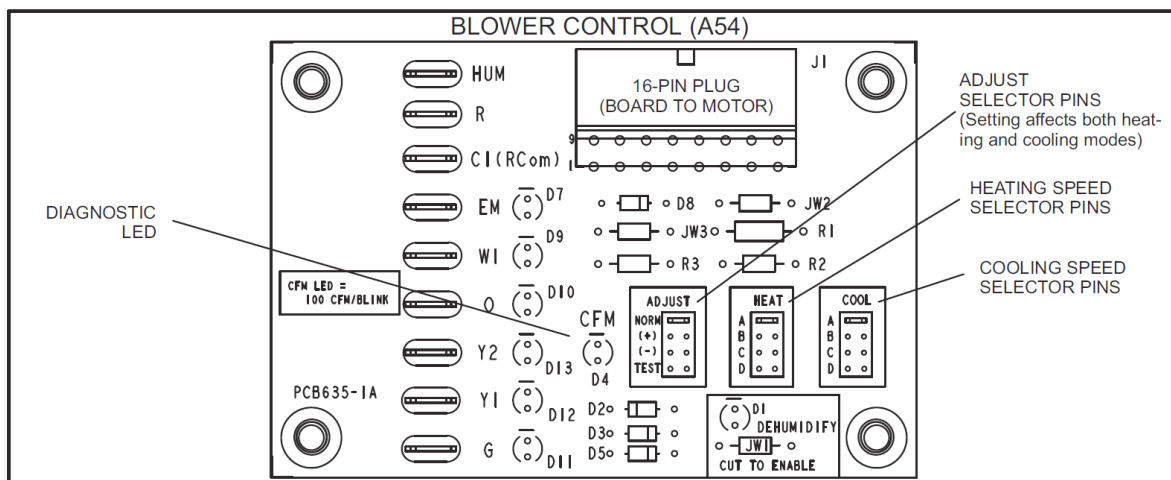

Figure 7.

In the cooling mode, the blower control delays blower operation for 5 seconds after the compressor starts. The blower continues to operate for 90 seconds after the compressor is de-energized. The delay is 5 minutes on the first start.

### HEAT

The HEAT jumper is used to determine CFM during electric heat operation only. These jumper selections are activated only when W1/W2 is energized.

### CONTINUOUS FAN

When the thermostat is set for "Continuous Fan" operation and there is no demand for heating or cooling, the blower control will provide 50 percent of the COOL CFM selected.

### DEHUMIDIFICATION

The blower control includes an HUM terminal, which provides for connection of a humidistat. The JV1 resistor on the blower control must be cut to activate the HUM terminal. The humidistat must be wired to open on humidity rise. When the dehumidification circuit is used, the variable speed motor will reduce the selected air flow rate by 25 percent when humidity levels are high. An LED (D1) lights when the blower is operating in the dehumidification mode.

### Cooling System

The cooling system is factory-charged with HFC-R-410A. The compressor is hermetically sealed and base-mounted with rubber-insulated bolts.

### Cooling

When the thermostat calls for cooling, R is closed to Y1 and O (see the wiring diagrams starting on Page 20). This action completes the low voltage control circuit, energizing the compressor, condenser fan motor, and blower motor. Second-stage cooling is initiated by the thermostat energizing Y2 in AC units and Y2 and O in heat pumps.

Unit compressors have internal protection. In the event there is an abnormal rise in the temperature of the compressor, the protector will open and cause the compressor to stop.

The thermostat automatically closes the R to G circuit, which brings on the indoor blower. Upon satisfying cooling demand, the thermostat will open the above circuits and open the main contactor, stopping the compressor and outdoor fan. If the unit is equipped with a delay timer, the blower will continue to operate for 60 to 90 seconds, which improves system efficiency.

### Heating - Heat Pump Stage

Upon heating demand, the thermostat closes circuit R to Y1, which closes the unit contactor, starting the compressor and outdoor fan. Second-stage heating is initiated when the thermostat energizes Y2, or when the outdoor ambient

temperature is below the lock-in temperature (see Second-Stage Lock-In section). The reversing valve is not energized in the heating mode. The thermostat again automatically brings on the indoor fan at the same time. Upon satisfying heating demand, the thermostat opens above circuits and stops unit operation.

**NOTE:** O is de-energized in heating mode.

### Heating - Auxiliary Electric Heat

Upon heating demand for auxiliary electric heat, the thermostat closes circuit R to W, which energizes the heater sequencers as well as the indoor blower. Upon satisfying auxiliary heat demand, the thermostat opens above circuits and heating elements sequence off; the blower continues to operate until all heating elements have turned off.

Auxiliary electric heat can be staged using W1, W2 on 10, 15 and 20 kW models. Staged wiring diagrams are included with the installation instructions of electric heater kits.

### Heating - Emergency Mode

When the thermostat calls for emergency heat, the R to W circuit is closed. Upon satisfying heat demand, the circuit is open and the blower continues to operate through an off delay period. The primary function of emergency mode is to provide emergency heat should the heat pump operation fail.

### Defrost System

The defrost system includes two components: the defrost thermostat and the defrost control.

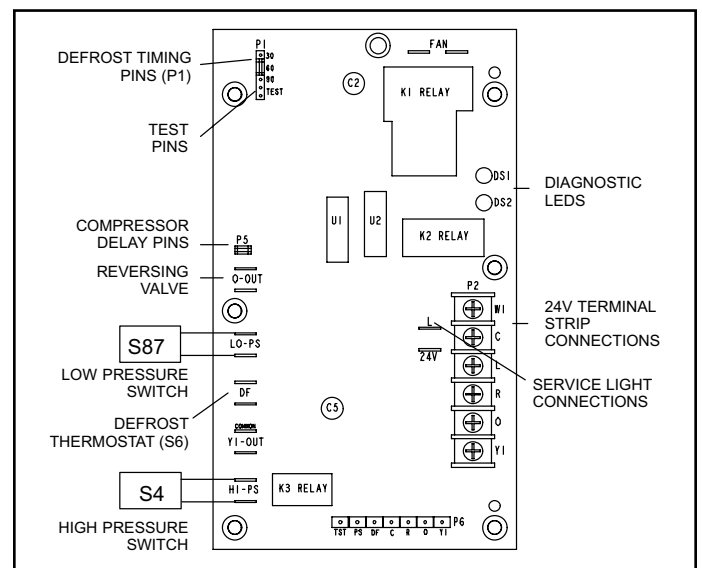

Figure 6. Defrost Control Board

### Defrost Thermostat

The defrost thermostat is located on the evaporator coil. When the defrost thermostat senses 35°F or cooler, the

thermostat contacts close and send a signal to the defrost control board to start the defrost timing. It also terminates defrost when the liquid line warms up to 60°F.

### Defrost Control

The defrost control board includes the combined functions of time/temperature defrost control, defrost relay, diagnostic LEDs and terminal strip for field wiring connections (see Figure 6).

The control provides automatic switching from normal heating operation to defrost mode and back. During the compressor cycle (call for defrost), the control accumulates compressor run time at 30, 60, and 90 minute field-adjustable intervals. If the defrost thermostat is closed when the selected compressor run time interval ends, the defrost relay is energized and the defrost begins.

1. An on-board outdoor ambient temperature sensor on the defrost control bypasses the low pressure switch during low ambient temperature below 15°F in heating mode to eliminate nuisance low pressure trips.

**NOTE:** 15°F is an approximate temperature, depending upon installation and geographic location.

2. A defrost cycle will initiate when there has been a low pressure switch trip; the defrost sensor must be closed and the defrost time interval must not have expired.
3. At the end of the defrost cycle, when the unit goes back to heating mode, the low pressure switch is checked to see if it has reset. If so, the strikeout is not counted. This prevents lockout during extreme winter conditions.

### Defrost Control Timing Pins

Each timing pin selection provides a different accumulated compressor run time period during one thermostat run cycle. This time period must occur before a defrost cycle is initiated. The defrost interval can be adjusted to 30 (T1), 60 (T2), or 90 (T3) minutes. **It is intended that this product should be set at the 60-minute time interval at initial installation.** If the timing selector jumper is not in place, the control defaults to a 90-minute defrost interval. The maximum defrost period is 14 minutes and cannot be adjusted.

#### NOTE:

For geographic areas that experience low temperature and high humidity conditions (below 35°F and above 80% RH), the defrost timer pin must be field set at installation to a 60 or 30 minute defrost interval to ensure reliable system operation while in heating mode.

A test option is provided for troubleshooting. The test mode may be started any time the unit is in the heating mode and the defrost thermostat is closed or jumpered. If the jumper is in the TEST position at power up, the control will ignore the test pins. When the jumper is placed across the TEST

pins for 2 seconds, the control will enter the defrost mode. If the jumper is removed before an additional 5-second period has elapsed (7 seconds total), the unit will remain in defrost mode until the defrost thermostat opens or 14 minutes have passed. If the jumper is not removed until after the additional 5-second period has elapsed, the defrost will terminate and the test option will not function again until the jumper is removed and reapplied.

### Second-Stage Lock-In

If first-stage output is active in heating mode and the outdoor ambient temperature is below the lock-in temperature (approximately 40°F), the second-stage output will be energized even without a Y2 room thermostat input.

### Compressor Delay (Quiet-Shift)

The defrost board has a field-selectable function to reduce occasional sounds that may occur while the unit is cycling in and out of the defrost mode. The compressor will be cycled off for 30 seconds going in and out of the defrost mode when the compressor delay jumper is removed.

**NOTE:** The 30-second "off" cycle is not functional when jumpering the TEST pins.

### Time Delay

The defrost control includes a compressor timer, which ensures the compressor is off for a minimum amount of time between operating cycles.

The timed-off delay is 5 minutes long. The delay helps to protect the compressor from short cycling in case the power to the unit is interrupted or a pressure switch opens. The delay is bypassed by placing the timer select jumper across the TEST pins for 0.5 seconds.

### Pressure Switch Circuit

High and low pressure switches are connected to the defrost control board on heat pump models. Air conditioning models have a high pressure switch installed in line with the compressor contactor coil (see Figure 6).

**During a single demand cycle, the defrost control will lock out the unit after the fifth time that the circuit is interrupted by any pressure switch wired to the control board. In addition, the diagnostic LEDs will indicate a locked-out pressure switch after the fifth occurrence of an open pressure switch (see Table 3).**

**The unit will remain locked out until power to the board is interrupted, then re-established, or until the jumper is applied to the TEST pins for 0.5 seconds.**

**NOTE:** The defrost control board ignores input from the low pressure switch terminals as follows:

- During the TEST mode
- During the defrost cycle

- During the 90-second start-up period
- For the first 90 seconds each time the reversing valve switches heat/cool modes

**If the TEST pins are jumpered and the 5-minute delay is being bypassed, the LO PS terminal signal is not ignored during the 90-second start-up period.**

### Diagnostic LEDs

The defrost board uses two LEDs for diagnostics. The LEDs flash a specific sequence according to the condition as shown in Table 3.

Defrost Board Diagnostic LEDs		
Green LED (DS2)	Red LED (DS1)	Condition
OFF	OFF	No Power to Control
Simultaneous Slow FLASH		Normal Operation / Power to Control
Alternating Slow FLASH		5-min Anti-Short-Cycle Delay
ON	Slow FLASH	Low Pressure Switch Ignored (Low Ambient)
Fault & Lockout Codes		
OFF	Slow FLASH	Low Pressure Switch Fault
OFF	ON	Low Pressure Switch Lockout
Slow FLASH	OFF	High Pressure Switch Fault
ON	OFF	High Pressure Switch Lockout

**Table 3. Defrost Control (CMC1) Diagnostic LEDs**

### System Performance

This equipment is a self-contained, factory optimized refrigerant system, and should not require adjustments to system charge when properly installed. If unit performance is questioned, perform the following checks.

Ensure unit is installed per manufacturer's instructions and that line voltage and air flow is correct. Refer to Table 4 through Table 6 for proper performance value. The indoor metering device varies by model.

If the measured performance value varies from table value allowance, check internal seals, service panels and duct work for air leaks, as well as restrictions and blower speed settings. If unit performance remains questionable, remove system charge, evacuate to 500 microns, and weigh in refrigerant to nameplate charge. It is critical that the exact charge is re-installed. Failure to comply will compromise system performance.

If unit performance is still questionable, check for refrigerant-related problems, such as blocked coil or circuits, malfunctioning metering device or other system components.

### Maintenance

#### WARNING

Before performing maintenance operations on the system, shut off all electrical power to the unit. Turn off accessory heater power switch if applicable. Electrical shock could cause personal injury or death.

Periodic inspection and maintenance normally consists of changing or cleaning the filters and cleaning the evaporator coil. On occasion, other components may also require cleaning.

#### Filters

Filters are not supplied with the unit. Inspect once a month. Replace disposable or clean permanent type as necessary. Do not replace permanent type with disposable.

#### Motors

Indoor and outdoor fan and vent motors are permanently lubricated and require no maintenance.

Some models may be equipped with a permanent magnet, constant torque indoor blower motor. These motors remain energized and are controlled by 24V signals. For high static applications, use tap 3 for cooling speed and tap 5 for heating speed. Refer to the heater installation label for limitations to blower tap selection on heating speeds.

#### Evaporator Coil

Dirt and debris should not be allowed to accumulate on the evaporator coil surface or other parts in the air circuit. Cleaning should be as often as necessary to keep coil clean. Use a brush, vacuum cleaner attachment, or other suitable means. If water is used to clean the coil, be sure the power to unit is shut off prior to cleaning. **Care should be used when cleaning the coil so that the coil fins are not damaged.**

**Do not permit the hot condenser air discharge to be obstructed by overhanging structures or shrubs.**

#### Condenser Coil

Clean condenser coil annually with water and inspect monthly during the cooling season.

Condenser coil may need to be cleaned at startup in case oil from the manufacturing process is found on the condenser coil.

**Table 4. Cooling Performance - AC Models**

80 DB / 67 WB Deg. Return Air		Air Temperature Entering Evaporator Coil, Degree F																					
		65°	70°	75°	80°	82°	85°	90°	95°	100°	105°	110°	115°										
COOLING INPUT (1000 BTU)	Pressure																						
	Suction	24	141	142	142	143	143	143	143	144	145	146	148	150	152	154							
		36	134	137	139	142	143	144	145	146	148	150	155	159	163								
		48	138	140	141	142	143	144	145	147	148	148	148	149	149								
60	135	136	137	138	138	139	140	142	142	144	145	147	148										
Liquid	24	230	249	269	288	296	310	333	356	384	413	441	469										
	36	254	273	291	310	317	332	356	381	401	422	442	462										
	48	251	273	275	316	325	339	363	387	416	444	473	501										
	60	259	278	296	315	322	336	360	384	411	437	464	490										

**Table 5. Cooling Performance - HP / DF Models**

80 DB / 67 WB Deg. Return Air		Air Temperature Entering Evaporator Coil, Degree F																					
		65°	70°	75°	80°	82°	85°	90°	95°	100°	105°	110°	115°										
COOLING INPUT (1000 BTU)	Pressure																						
	Suction	24	141	142	142	143	143	143	144	145	147	148	149	150									
		36	132	134	136	137	138	139	140	142	144	145	147	148									
		48	136	138	140	142	143	144	145	147	148	149	150	151									
60	134	135	137	138	139	140	141	142	144	145	147	148											
Liquid	24	237	257	278	298	306	320	343	366	392	419	445	471										
	36	239	260	280	301	309	323	347	370	397	424	451	478										
	48	243	264	284	305	313	327	351	374	401	428	454	481										
	60	249	270	292	313	322	337	361	385	414	443	472	501										

**Table 6. Heating Performance - HP / DF Models**

70 Deg. F Return Air		Air Temperature Entering Evaporator Coil, Degree F												
COOLING INPUT (1000 BTU)	Pressure	0°	5°	10°	17°	20°	25°	30°	35°	40°	47°	50°	55°	60°
24		28	36	44	56	61	69	78	86	94	106	113	124	135
36	Suction	26	33	40	50	54	61	68	75	83	95	103	117	131
48		28	36	43	53	57	65	72	79	89	102	107	116	125
60		31	39	46	56	60	68	75	82	89	99	106	117	128
24	Liquid	264	271	279	289	294	301	309	316	324	335	340	348	357
36		272	282	291	305	311	321	330	340	348	359	365	374	383
48		283	291	298	308	312	320	327	334	342	353	358	367	376
60		285	295	304	316	321	330	339	348	357	370	375	383	392

# Wiring Diagrams

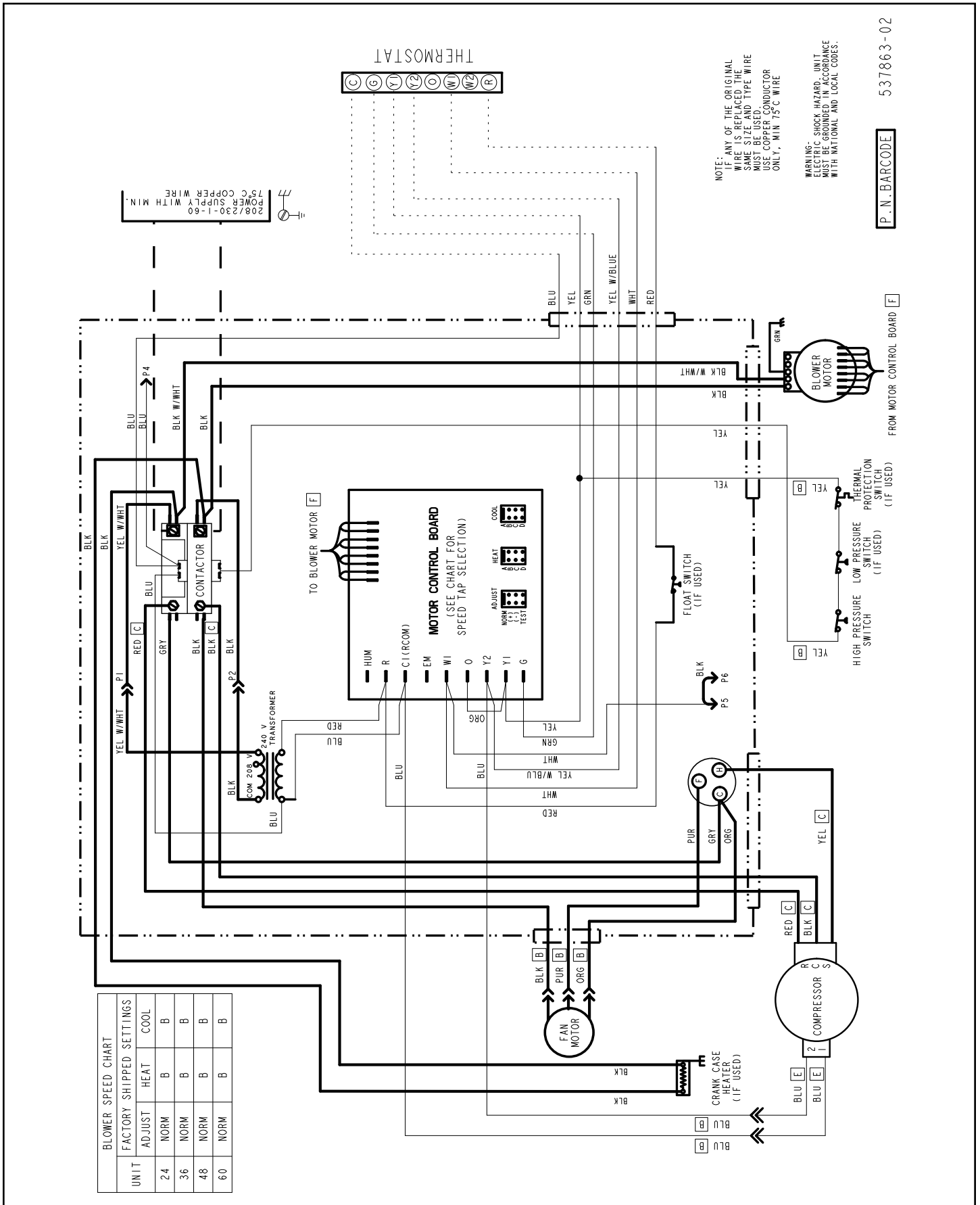

BLOWER SPEED CHART	
UNIT	FACTORY SHIPPED SETTINGS
	ADJUST HEAT COOL
24	NORM B B
36	NORM B B
48	NORM B B
60	NORM B B

**Figure 8. AC Wiring Diagram**

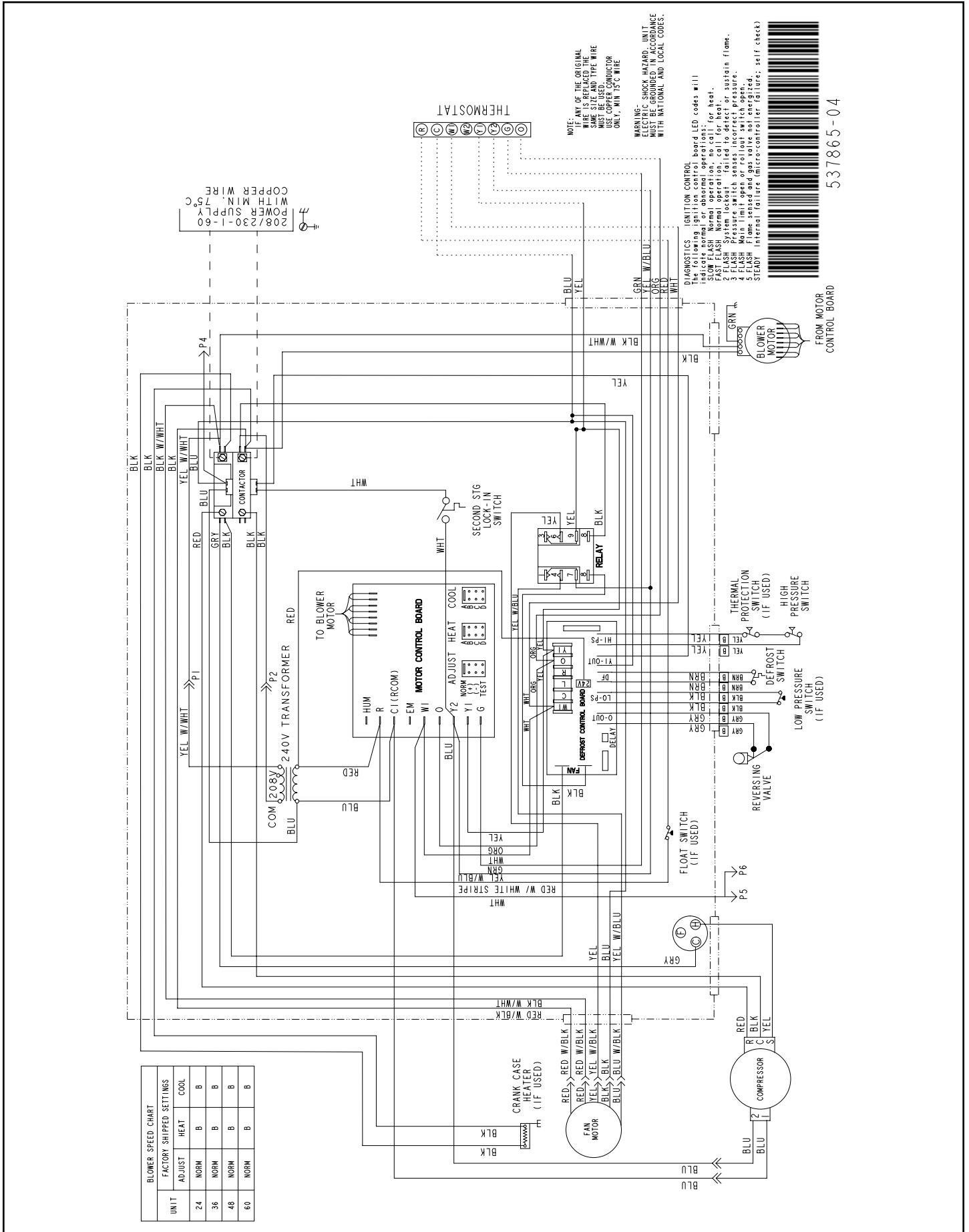

537865-04

Figure 9. HP Wiring Diagram