

# Optima Plus® EBF-85

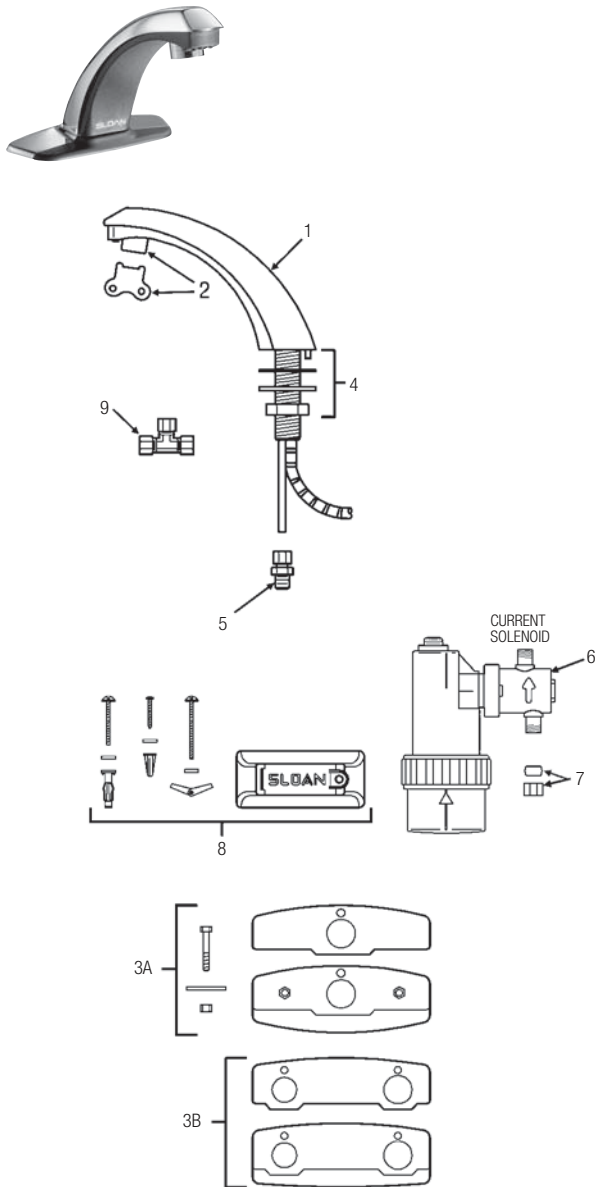

## PARTS LIST—EBF-85 FAUCET

Item No.	Code No.	Part No.	Description
1.	<b>3315016</b>	EBF-10-A	Faucet and Sensor Assembly (EBF-85)
—	<b>3315122</b>	EBF-1009-A	Fiber Optic Sensor Cable Assembly <b>Only</b> (replaces EBF-12-A and EBF-179-A includes lens holder)
2.	<b>3365091</b>	ETF-1021-A	0.5 gpm (1.9 Lpm) Spray Head with Key (female thread)
—	<b>3365090</b>	ETF-1022-A	2.2 gpm (8.3 Lpm) Aerator Spray Head with Key (female thread)
—	<b>3365161</b>	ETF-1028-A	1.5 gpm (5.7 Lpm) Laminar Flow Spray Head with Key (female thread)
—	<b>3365755</b>	ETF-1038-A	0.35 gpm (1.3 Lpm) Multi-Lam Spray Head VR
—	<b>0305927</b>	ETF-435	Replacement Key ONLY
3A.	<b>3365466</b>	ETF-295-A	4" (102 mm) Centerset Trim Plate Kit for Faucet (Faucet Only) includes two (2) Nuts, two (2) Hex Screws, two (2) Flat Washers, Single Hole Cover Plate, and CP Base Plate
3B.	<b>3365467</b>	ETF-299-A	4" (102 mm) Centerset Trim Plate Kit for Faucet with Optional Mixing Valve includes two (2) Nuts, two (2) Hex Screws, two (2) Flat Washers, Dual Hole Cover Plate, and CP Base Plate
4.	<b>0305626</b>	ETF-290-A	Faucet Mounting Kit includes Rubber Gasket, Mounting Washer, Mounting Nut, and Compression Fitting Connector
5.	<b>0305736</b>	ETF-297	1/4" to 3/8" Compression Fitting Connector
6.	<b>3315111</b>	EBF-11-A	Solenoid Valve Module Assembly includes Solenoid Enclosure, Solenoid Body, and Filter Cap
—	<b>3315009</b>	EBF-1001-A	Solenoid Filter Replacement Kit for old solenoid includes Filter Screen Assembly and O-ring
—	<b>3315028</b>	EBF-1004-A	Solenoid Filter Replacement Kit for current solenoid includes Filter Screen Assembly and O-ring
—	<b>3315051</b>	EBF-1005-A	Filter Cap Assembly for old solenoid includes metal Filter Cover and O-ring – <b>OBSOLETE</b>
7.	<b>3315001</b>	EBF-16-A	Single Supply Solenoid Kit with Ferrule Compression Nut
8.	<b>3315014</b>	EBF-25-A	Mounting Bracket Kit includes Base Plate, Wall Bracket Base, Wall Bracket, Mounting Screw, Self-tapping Screw, two (2) Wood Screws plus Washers and Plastic Anchors, two (2) Screws plus Washers and Toggle Nuts, two (2) Screws plus Washers and Hollow Wall Anchors
9.	<b>3365461</b>	ETF-617-A	Bak-Chek® "T" Assembly
10.	<b>0315004</b>	EBF-17	3/8" to 1/4" Compression Fitting Connector

— = Not shown in illustration

Hand Hygiene

## SOLENOID VALVE CHANGES

The current solenoid (in production since May 1998; part 7 shown on the left) has MALE inlet and outlet connections. The current style filter plug has a metal filter cap that can be removed with a 5/8" wrench.

The older solenoid valve (shown on the left) can be identified by FEMALE inlet and outlet connections. These require EBF-17 compression fittings (part 10 shown on the left).

This older style solenoid has either a plastic or a replacement brass filter cap. Remove the older brass filter cap with a 7/16" or 1/2" hex wrench. Replace the old style filter cap.

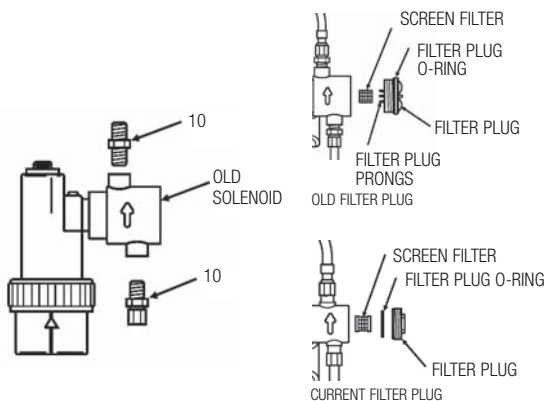

## Optima Plus® EBF-85

### TROUBLESHOOTING GUIDE

#### 1. Module emits audible “BEEPs” when activated.

- A. Battery power is nearly exhausted.  
To ensure proper operation, insert four (4) new C-size alkaline batteries. Check that the orientation of each battery matches the positive (+) and negative (-) symbols shown in the bottom of the battery compartment. Reattach battery compartment to control module.

#### 2. Sensor is activated but faucet does not deliver water.

**INDICATOR: Module DOES NOT produce audible “BEEPs”.**

- A. Battery power is fully exhausted.  
To ensure proper operation, insert four (4) new C-size alkaline batteries. Check that the orientation of each battery matches the positive (+) and negative (-) symbols shown in the bottom of the battery compartment. Reattach battery compartment to control module.
- B. Batteries are not installed properly.  
Check that the orientation of the batteries match the positive (+) and negative (-) symbols shown in the bottom of the battery compartment. Reattach the battery compartment to the control module.
- C. Solenoid valve module is not working properly.  
Replace EBF-11-A solenoid valve module.

**INDICATOR: Module produces audible “BEEPs” when batteries are installed and after 30-second calibration procedure, but NOT when a target is placed in the detection zone of the Sensor.**

- D. Fiber optic cable is not connected correctly to solenoid valve module or was not connected when batteries were installed.  
Reconnect fiber optic cable to solenoid valve module. Open battery compartment to reset electrical system. Check that the orientation of each battery matches the positive (+) and negative (-) symbols shown in the bottom of the battery compartment. Reattach the battery compartment to the control module.
- E. Fiber optic cable is not working properly.  
Replace EBF-1009-A sensor cable, or EBF-10-A faucet/sensor assembly.
- F. Solenoid valve module is not working properly.  
Replace EBF-11-A solenoid valve module.

**INDICATOR: Module produces audible “BEEPs” when a target is placed in the detection zone of the sensor and solenoid valve produces an audible “CLICK”, but NO water flows.**

- G. Water supply to faucet is not open.  
Open supply stop(s).
- H. Bak-Chek® is installed backwards.  
Reinstall Bak-Chek(s).
- I. Solenoid filter is clogged.  
Remove, clean, and reinsert. Replace with EBF-1001-A or EBF-1004-A solenoid filter kit if necessary.
- J. Aerator or spray head is clogged.  
Remove, clean, and reinsert.

**INDICATOR: Module produces audible “BEEPs” when a target is placed in the detection zone of the sensor, but solenoid valve does NOT produce an audible “CLICK” and NO water flows.**

- K. Solenoid valve module is not working properly.  
Replace EBF-11-A solenoid valve module.

#### 3. Faucet delivers only a slow flow or dribble when sensor is activated.

- A. Water supply valve is partially closed.  
Open the supply stop(s) completely.
- B. Solenoid filter is clogged.  
Remove, clean, and reinsert. Replace with EBF-1001-A or EBF-1004-A solenoid filter if necessary.
- C. Aerator or spray head is clogged.  
Remove, clean, and reinsert.

#### 4. Faucet does not stop delivering water or continues to drip after user is no longer detected (automatic shut-off fails even when batteries are removed).

- A. Solenoid valve has been connected backwards.  
Disassemble solenoid valve compression fittings at the inlet and outlet positions. Water should flow from inlet through the solenoid valve to outlet according to the direction shown by the arrow on the side of the solenoid valve. Reconnect the fittings in the correct orientation.
- B. Solenoid valve seat is dirty.  
Remove, clean, and reinsert solenoid filter. Activate faucet several times to flush out dirt.
- C. Solenoid valve is dirty.  
Backflush by reversing water flow (opposite to the direction shown by the arrow on the side of the solenoid valve) through the solenoid valve. Reconnect the compression fittings in the correct orientation. Activate faucet.
- D. Solenoid valve module is not working properly.  
Replace EBF-11-A solenoid valve module.

#### 5. The water temperature is too hot or too cold on a faucet connected to hot and cold supply lines with two Bak-Chek's.

- A. Supply stops are not adjusted properly.  
Adjust supply stops.
- B. One Bak-Chek is installed backwards.  
Reinstall Bak-Chek.

NOTE: For some systems, a thermostatic mixing valve may be required.

#### Battery replacement

