



PROJECT NAME _____
LOCATION _____
ARCHITECT _____
ENGINEER _____
CONTRACTOR _____
SUBMITTED BY _____ DATE _____

UNIT SUMMARY

Quantity						
Unit Designation						
Model No.						
Total Cooling						
Sensible Cooling						
Air Ent. Evaporator						
Air Lvg. Evaporator						
Heating Input						
Heating Output						
CFM/ESP						
EER/SEER						
Electrical						
Minimum Ampacity						
Min.-Max. Breaker						
Net Unit Weight						
Accessory						
Catalog Form Number						

ACCESSORIES:

NOTES:

Endeavor® Line RH1PY Air Handlers

PSC Motor

Single-Stage Airflow

Efficiencies: 13.4 to 15.2 SEER2

Refrigerant Type: R-454B

JOB NAME _____ LOCATION _____

CONTRACTOR _____ ORDER NO. _____

ENGINEER _____ UNIT MODEL NO. _____

SUBMITTED FOR APPROVAL RECORD COIL MODEL NO. _____

DATE _____ AIR HANDLER MODEL NO. _____

UNIT DATA

COOLING PERFORMANCE

TOTAL CAPACITY* MBH [kW]

SENSIBLE CAPACITY* MBH [kW]

OUTDOOR DESIGN TEMP..... °F [°C] DB

TOTAL SUPPLY AIR..... CFM [L/s]

TEMP. OF AIR ENTERING
EVAPORATOR COIL °F [°C] DB
..... °F [°C] WB

POWER INPUT REQUIREMENT kW
(*uses blower motor heat)

HEATING PERFORMANCE

TOTAL CAPACITY* MBH [kW]

OUTDOOR DESIGN TEMP..... °F [°C] DB

TEMP. OF AIR ENTERING
EVAPORATOR COIL °F [°C] DB
..... °F [°C] WB

ELECTRIC HEAT CAPACITY kW

POWER INPUT REQUIREMENT kW
(*uses blower motor heat)

SUPPLY AIR BLOWER PERFORMANCE

TOTAL AIR SUPPLY..... CFM [L/s]

TOTAL RESISTANCE EXTERNAL
TO UNIT IWG

BLOWER SPEED..... RPM

POWER OUTPUT REQUIREMENT BHP

MOTOR RATING HP [W]

POWER INPUT REQUIREMENT kW

ELECTRICAL DATA

POWER SUPPLY Hz

TOTAL UNIT AMPACITY..... AMPS

MINIMUM WIRE SIZE AWG

MAXIMUM OVERCURRENT DEVICE
FUSES/HACR BREAKER AMPS

CLEARANCES

SERVICE ACCESS FRONT 24" [609.6 mm]

FEATURES

- **Quiet Operation¹:** Provided by a cabinet construction with 1.0 inch of foil faced insulation for quieter sound characteristics
- **Aluminum Indoor Coil Design:** Are constructed of aluminum fins bonded to internally grooved aluminum tubing and are more corrosion resistant
- **Versatile 4-Way Convertible Compact Design:** Allows for upflow, downflow, horizontal left and horizontal right applications, even in the smallest of spaces
- **Rugged Steel, Compact Cabinet Construction:** Designed for added strength and versatility
- **Field-installed Auxiliary Heater Kits:** Provide exact heat for indoor comfort and include circuit breakers which meet UL and cUL requirements for service disconnect
- **Cabinet air leakage less than 2% at 1 inch H₂O** when tested in accordance with ASHRAE Standard 193
- **Designing for Sustainability with Low GWP:** For 2025, the Environmental Protection Agency (EPA) has set a global warming potential (GWP) limit of 700 for refrigerant used in heating and cooling systems. This new requirement will result in a 78%² lower GWP than previous-generation refrigerants — with only minimal changes to system installation. For us, this is another step toward our continued sustainability goal of reducing greenhouse gas emissions, while still delivering an exceptional level of energy efficient, dependable comfort
- **PlusOne® Refrigerant Detection System^{TM3}:** An integrated one-box, patented design featuring the A2L sensor and mitigation board, offering easier commissioning with a single component and simplified wiring configuration, compatibility with any 24V thermostat application and system protection by automatically pausing outdoor unit operation — if excess refrigerant is detected

¹Based on manufacturer's air handler offering, and the product's airflow stages, motor type and cabinet insulation. Sound levels are also dependent on air handler location and installation

²When comparing the GWP of R-454B to R-410A refrigerant

³Factory or field installed in the furnace coil or air handler and is applicable to the complete heating and cooling system featuring Low GWP Refrigerant (A2L)



RH1PY

ELECTRICAL CONNECTIONS
MAY EXIT TOP OR EITHER SIDE

HIGH VOLTAGE CONNECTION 7/8" [22.2 mm],
1 3/32" [27.8 mm], 1 3/16" [50 mm] DIA. KNOCKOUTS.

LOW VOLTAGE CONNECTION
3/8" [15.9 mm] AND 7/8" [22.2 mm] KNOCKOUT

AUXILIARY DRAIN CONNECTION
3/4" [19.1 mm] FEMALE PIPE THREAD (NPT)
HORIZONTAL APPLICATION ONLY

PRIMARY DRAIN CONNECTION
3/4" [19.1 mm] FEMALE PIPE THREAD (NPT)

AUXILIARY DRAIN CONNECTION
3/4" [19.1 mm] FEMALE PIPE THREAD (NPT)
UPFLOW/DOWNFLOW APPLICATION ONLY

LIQUID LINE CONNECTION
COPPER (SWEAT)

VAPOR LINE CONNECTION
COPPER (SWEAT)

SUPPLY AIR ↑

NOTE: 24" CLEARANCE REQUIRED IN FRONT OF
UNIT FOR FILTER AND COIL MAINTENANCE.

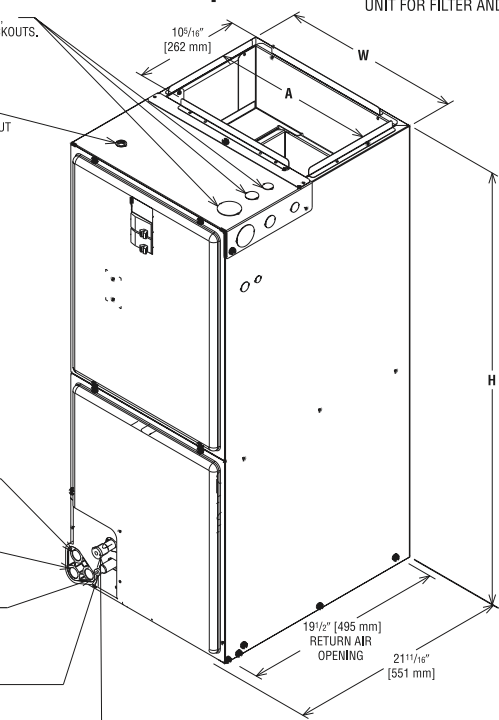

UPFLOW UNIT SHOWN:
UNIT MAY BE INSTALLED UPFLOW, DOWNFLOW,
HORIZONTAL RIGHT OR LEFT AIR SUPPLY.

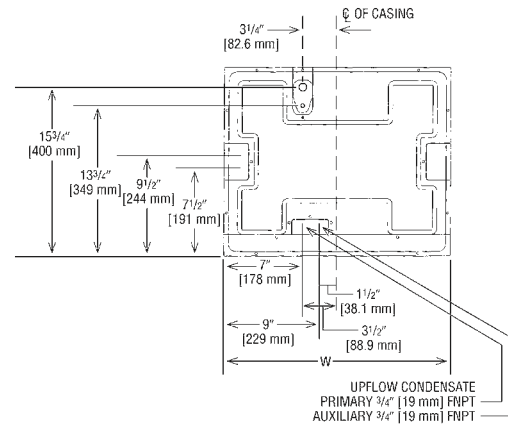

Unit Dimensions

Model Size RH1PY	Refrigerant Connections Sweat (In.) [mm] ID		Unit Width "W" In. [mm]	Unit Height "H" In. [mm]	Supply Duct "A" In. [mm]	Air Flow CFM (Nom.) [L/s]		Unit Weight/Shipping Weight (Lbs.) [kg] Unit With Coil (Max. KW)
	Liquid	Vapor				Lo	Hi	
1817S/2417S	3/8 [9.53]	3/4 [19.05]	17 1/2 [445]	42 1/2 [1080]	16 [406]	600 [283]	800 [378]	81/95 [37/43]
3017S/3617S	3/8 [9.53]	3/4 [19.05]	17 1/2 [445]	42 1/2 [1080]	16 [406]	1000 [472]	1200 [566]	90/104 [41/47]
3621S	3/8 [9.53]	7/8 [22.23]	21 [533]	42 1/2 [1080]	19 1/2 [495]	1200 [566]	—	109/124 [49/56]
4221S/4821S	3/8 [9.53]	7/8 [22.23]	21 [533]	50 1/2 [1282]	19 1/2 [495]	1400 [661]	1600 [755]	130/146 [59/66]
4824S	3/8 [9.53]	7/8 [22.23]	24 1/2 [622]	55 1/2 [1410]	23 [584]	1600 [755]	—	143/161 [65/73]
6024S	3/8 [9.53]	7/8 [22.23]	24 1/2 [622]	55 1/2 [1410]	23 [584]	—	1800 [850]	164/181 [75/82]

[] Designates Metric Conversions

Before proceeding with installation, refer to installation instructions packaged with each model, as well as complying with all Federal, State, Provincial, and Local codes, regulations, and practices.

5600 Old Greenwood Road
Fort Smith, Arkansas 72908

© 2024 Rheem Manufacturing Company. Rheem and Ruud trademarks owned by Rheem Manufacturing Company.

"In keeping with its policy of continuous progress and product improvement, Rheem reserves the right to make changes without notice."