

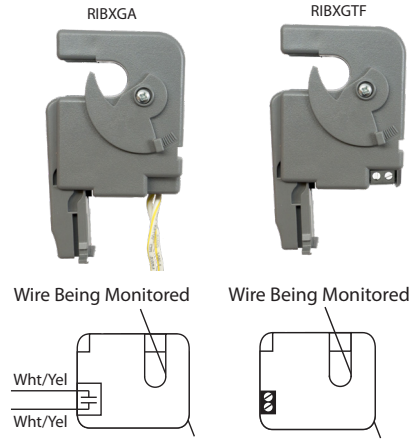

**AC CURRENT SWITCHES**

**RIBXG Series**

Enclosed Self-Powered Split Core AC Sensors

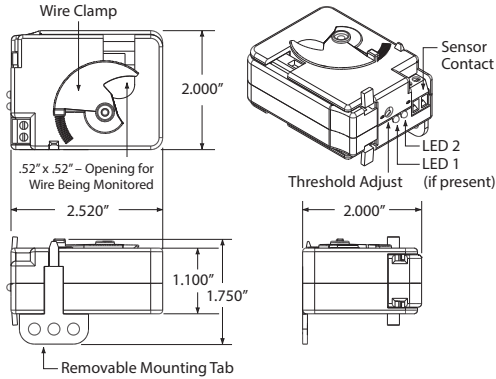

**SPECIFICATIONS**

**Operating Temperature:** -30 to 140° F  
**Humidity Range:** 5 to 95% (noncondensing)  
**Max Sense Voltage:** 600 Vac  
**Approvals:** UL Listed, UL916, UL864, C-UL, California State Fire Marshal, CE, RoHS  
**Mounting/Installation:** Removable mounting tab provided. The wire clamp locks against the wire being monitored, securing the unit in place.  
**Sensor Contact Status:** Current below threshold: Open  
 Current above threshold: Closed

**FUNCTIONAL DEVICES CERTIFIED FOR USE WITH ECMs**

**Sensor Contact:**  
 • Solid State Contact  
 • When sensor contact is off (open), leakage <30 uA @ 30Vac/dc  
 • When sensor contact is on (closed), voltage drop <.3 Vac/dc @ .1 Amp < 1.6 Vac/dc @ .4 Amp

**SELF-CALIBRATING AC SWITCHES** (Models with -SCAL Suffix)

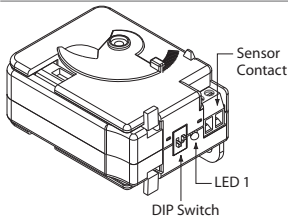

-SCAL LED TABLE	
LED Off	No Current
Two Winks	Current Below Range
Three Winks	Current In Range
Four Winks	Current Above Range
Continuous Winks	Calibration in Progress

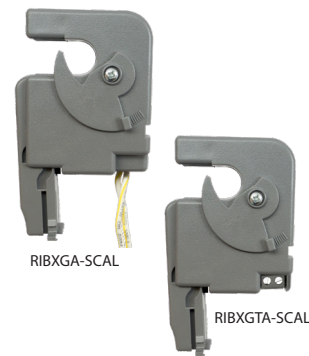

The SCAL unit begins the 30 second self-calibration process the first time current is applied in the operating range. The threshold is then set. Subsequent calibrations may be performed by moving SW1 to the position opposite of its current position with or without current applied (hands can be safely away from live voltage). Once current begins flowing, or if it already is, the calibration process will begin. At the end of the 30 seconds, amperage will be read and set as the threshold. SW2 in the ON position provides a 15% (+/-3%) differential. In the OFF position, it provides a 25% (+/-3%) differential. SW2 can be selected at anytime and does not affect the threshold setting. Current in-range closes the sensor contact. Current above or below range opens the sensor contact.

Example: With a current of 10 amps set as the threshold and a 15% differential, sensor contact will be closed between 8.5 amps and 11.5 amps and open outside of this range. A small amount of hysteresis is provided to prevent dithering near the differential limits.

**RIBXG SERIES SELECTION GUIDE**

Model#	Sensing Range	Type	Threshold	Sensor Contact Type	Switching Voltage Range	Maximum Switching Current	Sensor Contact Termination	LED 1	LED 2
RIBXGF	.35-150 Amp	Split Core	Fixed, .35 Amp	Solid State Switch SPST	30 Vac/dc	.4 Amps Max	Wht/Yel 16" 18 AWG Wire Leads		
RIBXGFL*	.75-150 Amp	Split Core	Fixed, .75 Amp	Solid State Switch SPST	30 Vac/dc	.4 Amps Max	Wht/Yel 16" 18 AWG Wire Leads	Over Trip Point	
RIBXGTF	.35-150 Amp	Split Core	Fixed, .35 Amp	Solid State Switch SPST	30 Vac/dc	.4 Amps Max	Terminal Strip, Accepts #14-22 AWG Wire		
RIBXGTFL*	.75-150 Amp	Split Core	Fixed, .75 Amp	Solid State Switch SPST	30 Vac/dc	.4 Amps Max	Terminal Strip, Accepts #14-22 AWG Wire	Over Trip Point	
RIBXGA	.75-150 Amp	Split Core	Adjustable	Solid State Switch SPST	30 Vac/dc	.4 Amps Max	Wht/Yel 16" 18 AWG Wire Leads	Over Trip Point	Under Trip Point
RIBXGTA	.75-150 Amp	Split Core	Adjustable	Solid State Switch SPST	30 Vac/dc	.4 Amps Max	Terminal Strip, Accepts #14-22 AWG Wire	Over Trip Point	Under Trip Point
RIBXGA-SCAL	3-150 Amp	Split Core	Self-Cal.	Solid State Switch SPST	30 Vac/dc	.4 Amps Max	Wht/Yel 16" 18 AWG Wire Leads	See -SCAL Table	
RIBXGTA-SCAL	3-150 Amp	Split Core	Self-Cal.	Solid State Switch SPST	30 Vac/dc	.4 Amps Max	Terminal Strip, Accepts #14-22 AWG Wire	See -SCAL Table	
RIBXGTA-ECM	.25-150 Amp	Split Core	Adjustable	Solid State Switch SPST	30 Vac/dc	.4 Amps Max	Terminal Strip, Accepts #14-22 AWG Wire	Over Trip Point	Load Current Detcted

\* = Not approved by California State Fire Marshal