

Series SB7 Ball Valve

Three-Piece *CleanFLOW™* High Purity Ball Valve
Sizes 1/2" ~ 6"



CleanFLOW™ SB7 ball valves are engineered to be a true process piping component to specifically meet the demanding processes found in the pharmaceutical and food & beverage industries. The "Tube-ID" port opening is dimensionally identical to the adjacent tubing to comply with latest ASME-BPE guidelines. All materials are compliant with FDA, USDA and 3A standards.

SERIES SB7 DESIGN FEATURES

- ✓ ASME-BPE compliant
- ✓ Silicone Free
- ✓ Cavity filled TFM1600™ seat option available
- ✓ Complete 316L Stainless Steel cast construction
- ✓ Drainable design with "Tube-ID" dimensions
- ✓ Weld bosses for easy purge porting on ends
- ✓ ISO 5211 mounting pad for easy actuation
- ✓ Encapsulated body seals to facilitate welding without disassembly
- ✓ End connections include Tri-Clamp and Extended Tube O.D.
- ✓ Controlled delta ferrite chemistry
- ✓ Chevron (V-Ring) Stem Seals assures low friction and leak tight performance (Sizes 2-1/2" ~ 4" only)
- ✓ Standard interior finish is 15Ra or better
- ✓ ETO ends are designed for Orbital Welding
- ✓ Exclusive "Fine Adjust" handle for precise positioning on sizes 1/2" ~ 2"
- ✓ Locking device is standard on 3" and 4" valves

MATERIALS OF CONSTRUCTION

ITEM	DESCRIPTION	MATERIALS SPECIFICATIONS
1	Body	316L Stainless Steel (ASTM A351 CF3MN)
2	End Connector	316L Stainless Steel (ASTM A351 CF3MN)
3	Ball	316L Stainless Steel (ASTM A351 CF3MN)
4	Stem	316L Stainless Steel (ASTM A351 CF3MN)
5	Seat	TFM1600™
6	Body Seal	PTFE, TFM1600™
7	Stem Seal	TFM1600™
8	Locking Device (Optional)	304 Stainless Steel

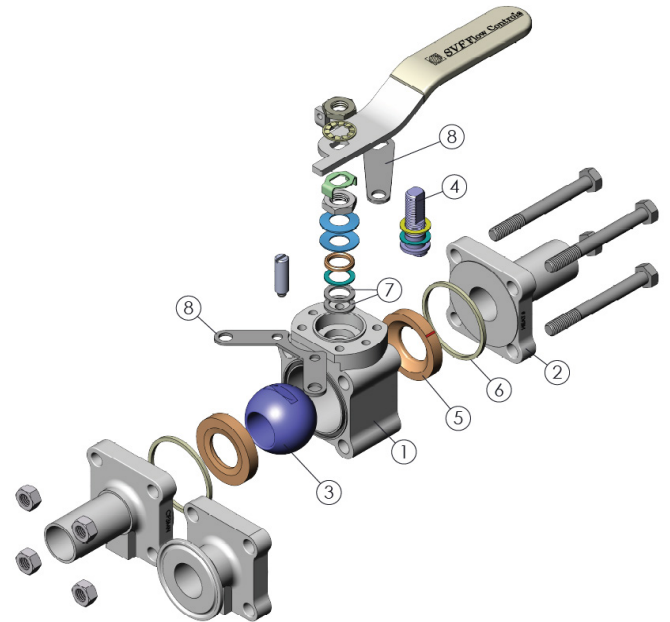
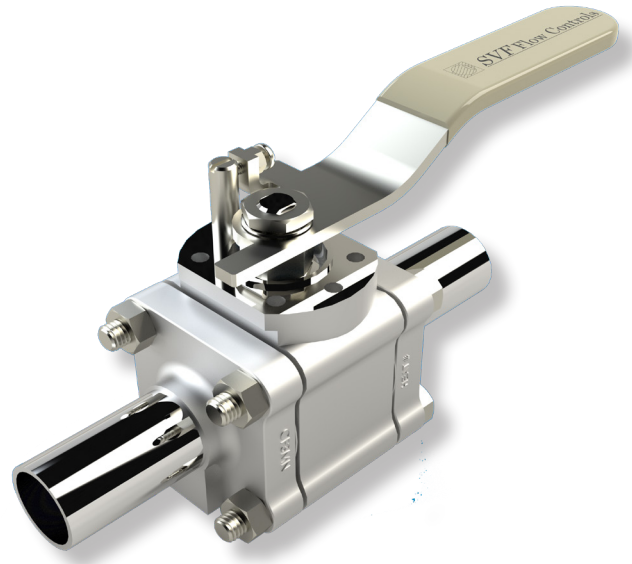

The Series SB7 Ball Valve is available with additional options.

There are no elastomers used for any of the components on the SB7 valves.
Only PTFE and TFM are used for seats and seals.

What do you need today?™



Series SB7 Ball Valve

Three-Piece *CleanFLOW™* High Purity Ball Valve
 Sizes 1/2" ~ 6"



DIMENSIONS, WEIGHT, CV, TORQUE

Size	A-1		A-2		B		D		L		W		Weight		Cv	Torque* Non-Cavity		Torque* Cavity	
	in.	mm	in.	mm	in.	mm	in.	mm	in.	mm	in.	mm	lbs	kg		in-lbf	Nm	in-lbf	Nm
1/2"	5.50	140	3.50	89	0.37	9	5	114	2.22	56	0.065	1.7	2	0.9	8	60	7	100	11
3/4"	6.00	152	4.00	102	0.62	16	5	114	2.28	58	0.065	1.7	2	0.9	29	60	7	140	16
1"	6.50	165	4.50	114	0.87	22	6	146	2.56	65	0.065	1.7	4	1.8	66	100	11	210	24
1-1/2"	7.50	191	5.50	140	1.37	35	7	178	3.09	78	0.065	1.7	8	3.6	192	200	23	490	55
2"	8.00	203	6.25	159	1.87	47	7	178	3.45	88	0.065	1.7	13	5.9	434	250	28	520	59
2-1/2"	9.50	241	6.75	171	2.37	60	10	254	5.35	136	0.065	1.7	23	10.4	723	450	51	900	102
3"	10.50	267	7.00	178	2.87	73	14	348	6.55	166	0.065	1.7	31	14.1	1124	1300	147	1400	158
4"	12.50	318	8.50	216	3.83	97	22	559	7.14	181	0.083	2.1	46	20.9	2100	1400	158	1500	170
6"	16.00	406	17.00	432	5.78	147	26	660	12.00	305	0.109	2.8	196	88.5	4700	4160	470	-	-

SB7 - PRESSURE/TEMPERATURE CHART

* At full differential pressure for clean fluids

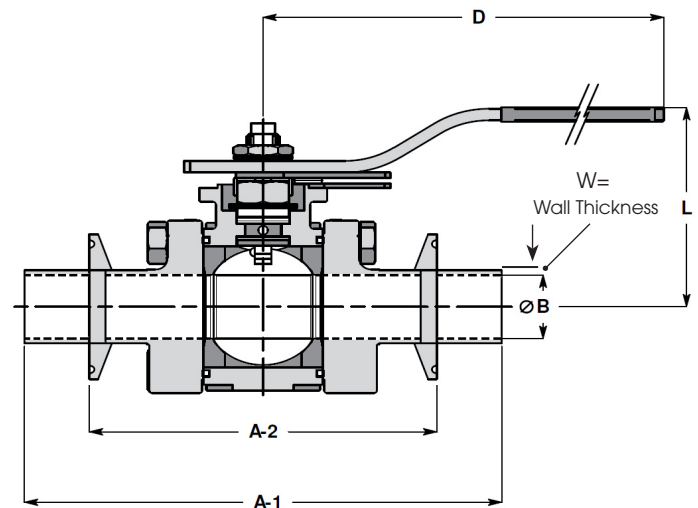
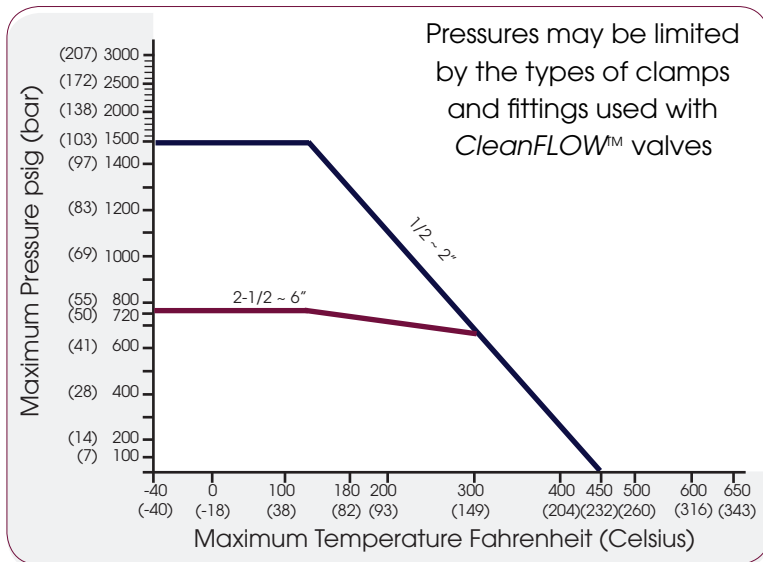

Class 600 (Sizes: 1/2" to 2")

Class 300 (Sizes: 2-1/2" to 6")

Series SB7 Ball Valve

Three-Piece *CleanFLOW™* High Purity Ball Valve
 Sizes 1/2" ~ 6"



How To Order Guide (Columns 1 thru 11)

1 SERIES	2 BODY	3 ENDS	4 BALL	5 STEM	6 SEAT MATERIAL
SB70	6 = 316L Stainless Steel ASTM A351 CF3MN	6 = 316L Stainless Steel ASTM A351 CF3MN	6 = 316L Stainless Steel ASTM A351 CF3M	6 = 316L Stainless Steel ASTM A351 CF3M	A = TFM1600™ Q = TFM1600™ Cavity Filled

7 BODY SEAL	8 END CONNECTIONS	9 VALVE SIZE	10 OPTIONS*	11 SPECIAL SERVICES*
T = PTFE A = TFM1600™ (Size 6" only)	TR0 = Tri-Clamp Ends ETO = Extended Tube-OD Ends JAH = Extended Tube-OD End X Tri-Clamp End (Extended Tube-OD End is under the handle on manual valves) JAA = Tri-Clamp End X Extended Tube-OD End (Tri-Clamp End is under the handle on manual valves)	005 = 1/2" 007 = 3/4" 010 = 1" 015 = 1-1/2" 020 = 2" 025 = 2-1/2" 030 = 3" 040 = 4" 060 = 6"	00 = None LK = Locking Device OH** = Oval Handle AA = Oval Handle & Locking Device AC = Locking Device & Anti-Static Device AG = ISO Stem Extension & Locking Device JA = Oval Handle, ISO Stem Extension & Locking Device JB = Oval Handle, ISO Stem Extension & Anti-Static Device JE = Locking Device, ISO Stem Extension & Anti-Static Device	00 = None XC = Oxygen Cleaned EP = Electropolished SB = 10Ra ID Finish AB = Electropolished & 10Ra ID Finish AD = Oxygen Cleaned & Electropolished JB = Electropolished, Oxygen Cleaned & 10Ra ID Finish

Order Example: (SB706666ATETO0050000) The Part Number will contain 20 digits.

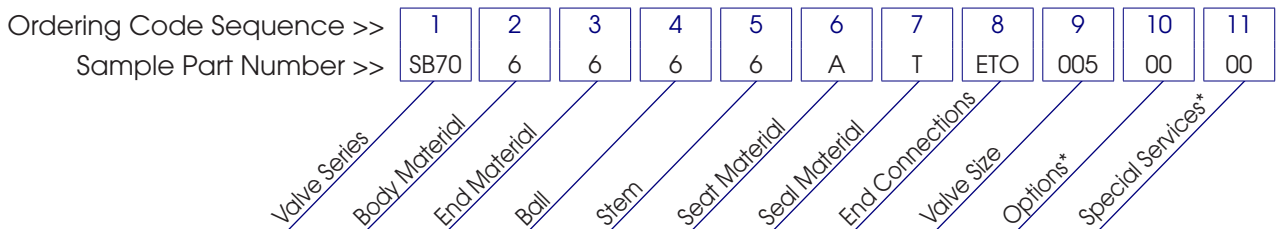

*Not all Options or Special Services available on all ball valves. Consult SVF for additional information.
 **Oval handles are only available up to size 2"