

# SUBMITTAL DATA SHEET

## Gas Meter Bars – 6722 -C

FNPT X FNPT

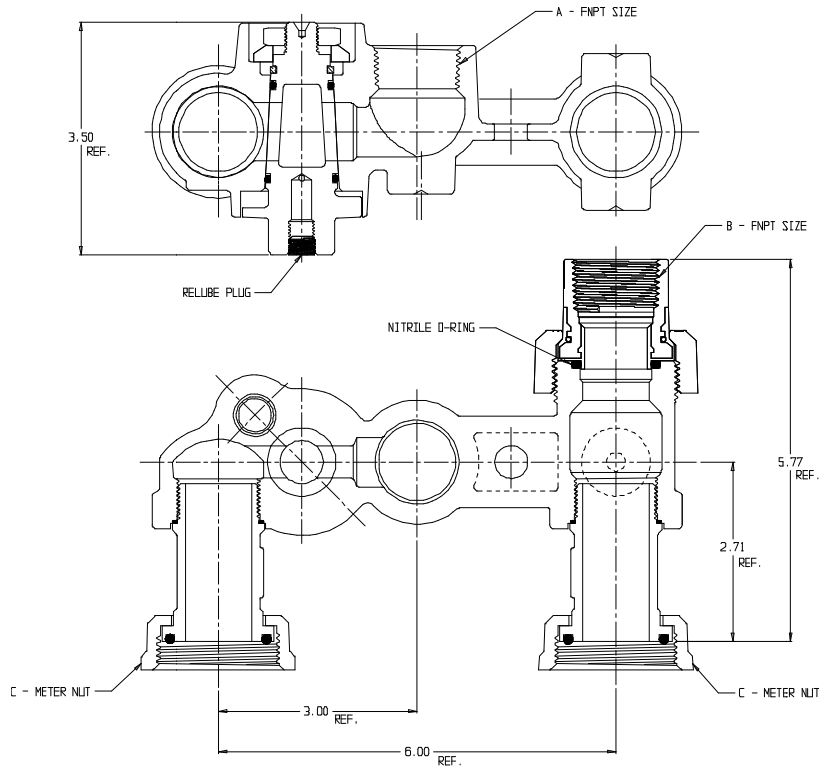
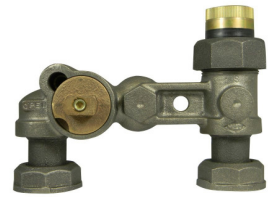

SIZES AVAILABLE				
A	3/4"	1"		
B	3/4"	1"		
C	1A	10LT	20LT	30LT

### SUBMITTAL INFORMATION

- Iron castings conform to ASTM A126 Class B Iron, with optional zinc coating per ASTM B633 with clear chromate coating and silicate sealer (latest revisions)
- Brass castings conform to ASTM B584, UNS C83600 or C84400 (latest revision)
- Pipe threads manufactured in compliance with ASME/ANSI B1.20.1 (latest revision)
- Meter nuts and swivels manufactured in compliance with ANSI B109.1 (latest revision)
- Tamper-resistant design prevents disassembly with normal household tools
- Design accommodates standard barrel locks
- Pressure test taps available in multiple positions and sizes
- Rated for 2 PSIG natural, manufactured, or LP gas pressure



**A.Y. McDonald Mfg. Co.**  
P.O. Box 508  
Dubuque, IA 52004-508

**Toll Free: 1-800-292-2737**  
**Fax: 1-800-832-9296**  
**Hours: 7:00 a.m. – 5:00 p.m., CST**

[sales@aymcdonald.com](mailto:sales@aymcdonald.com)  
[www.aymcdonald.com](http://www.aymcdonald.com)

A.Y. McDonald considers the information on this assembly drawing correct when published. Item and option availability, including specifications, are subject to change without notice.

**Submitted by:**