

INTRODUCING THE NEW SUPER-STOR ULTRA

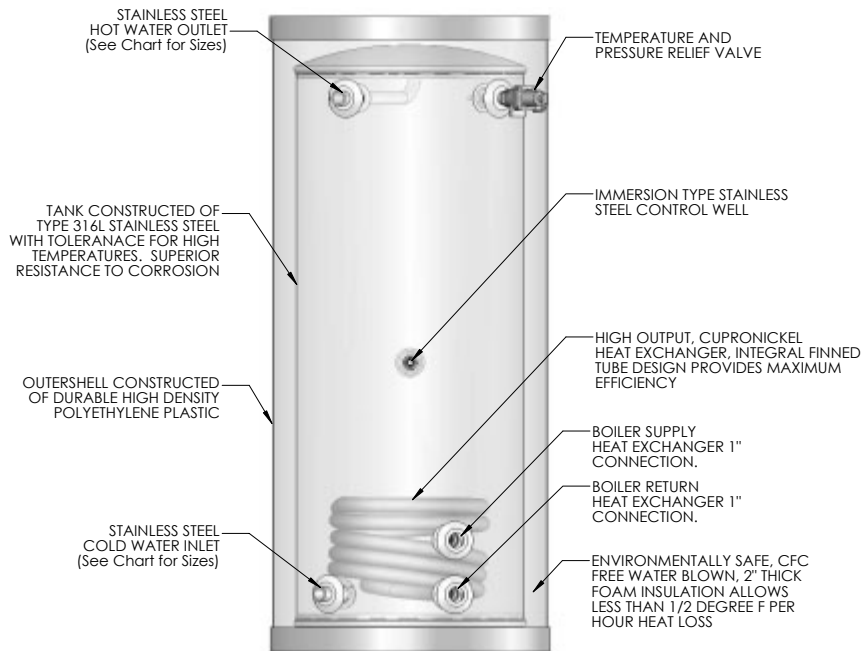

LP-83-AA
REV. 8/29/07

SPECIFICATIONS AND PERFORMANCE RATINGS

ULTRA RESIDENTIAL SERIES

MODEL	DIMENSIONS		CAPACITY	HEAT EXCH. SURFACE	RECOMM. FLOW RATE	PRESSURE DROP (FEET)	180° BOILER WATER FIRST HOUR RATINGS*		200° BOILER WATER FIRST HOUR RATINGS*	
	HT.	DIA.					140°F	115°F	140°F	115°F
SSU-20	27"	19 1/4"	20	15 SQ. FT.	8	6.0	121 gal	168 gal	136 gal	185 gal
SSU-30	39 1/2"	19 1/4"	30	15 SQ. FT.	8	6.0	154 gal	212 gal	172 gal	234 gal
SSU-30LB	28 1/2"	23 1/4"	30	15 SQ. FT.	8	6.0	169 gal	234 gal	189 gal	257 gal
SSU-45	52 1/2"	19 1/4"	45	20 SQ. FT.	10	7.9	212 gal	292 gal	237 gal	322 gal
SSU-60	52 1/2"	23 1/4"	60	20 SQ. FT.	10	7.9	266 gal	370 gal	298 gal	405 gal
SSU-80	72"	23 1/4"	80	34 SQ. FT.	12	9.1	330 gal	440 gal	370 gal	503 gal
SSU-119	73 1/2"	27"	119	34 SQ. FT.	14	11.3	423 gal	564 gal	474 gal	645 gal

*DOE TEST METHOD BASED ON 90°F. TEMPERATURE RISE, 50°/140° W/ BOILER WATER AT 180°F

TANK SIZE	FLOOR TO BOILER SUPPLY	FLOOR TO BOILER RETURN	FLOOR TO DOMESTIC OUT	DOMESTIC CONNECTIONS	TEST PRESSURE	WORKING PRESSURE	SHIPPING WEIGHT	180 BOILER BTU/SIZE	200 BOILER BTU/SIZE
SSU-20	9"	4 1/2"	22"	3/4 NPT MALE	300 PSI	150 PSI	60 LBS.	84,000	87,000
SSU-30	9"	4 1/2"	34"	3/4 NPT MALE	300 PSI	150 PSI	72 LBS.	102,000	117,000
SSU-30LB	9"	4 1/2"	22"	3/4 NPT MALE	300 PSI	150 PSI	79 LBS.	114,000	131,000
SSU-45	9"	4 1/2"	46"	3/4 NPT MALE	300 PSI	150 PSI	88 LBS.	141,000	161,000
SSU-60	9"	4 1/2"	46"	1" NPT MALE	300 PSI	150 PSI	110 LBS.	174,000	198,000
SSU-80	29"	6"	64.75"	1 1/2" NPT MALE	300 PSI	150 PSI	141 LBS.	212,000	241,000
SSU-119	30 1/4"	7 1/4"	66"	1 1/2" NPT MALE	300 PSI	150 PSI	210 LBS.	269,000	301,000

NOTE: TANK RECOVERY FROM COLD START WILL BE BETWEEN 10-13 MINUTES WHEN SIZED WITH CORRECT FLOW RATE, BOILER SIZE, AND PRESSURE DROP RATINGS FROM LIST IN ABOVE CHART.