



ADJUSTABLE SWIVEL RING HANGERS



COPPER TUBING SWIVEL RING

FUNCTION: Designed for the suspension of non-insulated stationary copper tubing. The knurled insert, allows for vertical adjustment after installation. The PVC coating on Fig. 154 protects the tubing from contact with the metal surface of the hanger.

APPROVALS: Complies with Federal Specification A-A-1192A (Type 10) and Manufacturers' Standardization Society SP-69 (Type 10).

ORDERING: Specify tube size and figure number.

Fig. 152 COPPER COLOR EPOXY FINISH

Fig. 154 COPPER COLOR EPOXY FINISH WITH PVC COATING

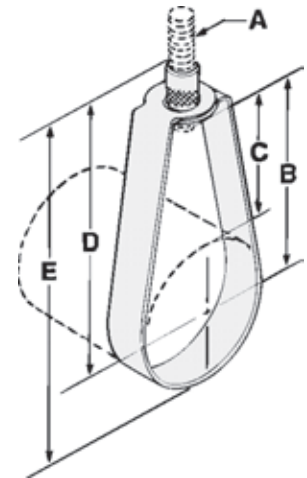

MATERIAL: Low carbon steel

Tube Size	Rod Size A	B	Adj. C	D	E	Max. Rec. Load/lbs.	Wt. Each (in lbs.)
1/2	3/8	1 13/16	1 1/2	2 11/16	3	300	.07
3/4	3/8	1 5/8	1 3/16	2 1/2	2 15/16	300	.07
1	3/8	1 9/16	1	2 9/16	3	300	.07
1 1/4	3/8	1 5/8	1 5/16	2 1/2	3 3/16	300	.08
1 1/2	3/8	1 11/16	7/8	2 9/16	3 3/8	300	.08
2	3/8	2 7/16	1 3/8	3 5/16	4 3/8	300	.10
2 1/2	1/2	2 13/16	1 1/2	3 7/8	5 9/16	525	.31
3	1/2	3 3/8	1 9/16	4 3/16	5 3/4	525	.34
3 1/2	1/2	3 1/2	1 11/16	4 9/16	6 3/8	525	.37
4	1/2	3 3/4	1 11/16	4 13/16	6 15/16	650	.41
5	1/2	4 1/8	1 9/16	5 3/16	7 13/16	1000	.47
6	1/2	4 5/8	1 9/16	5 11/16	8 15/16	1000	.53

PVC COATED SWIVEL RING

FUNCTION: Designed for the suspension of non-insulated stationary pipe lines. The PVC coating on Fig. 153 protects the pipe from contact with the metal surface of the hanger. Frequently used with Aluminum, Glass, Plastic, Brass or Copper pipe lines. Underwriters' Laboratories listed and Factory Mutual approved 3/4" to 8" sizes only.

APPROVALS: Complies with Federal Specification A-A-1192A (Type 10) and Manufacturers' Standardization Society SP-69 (Type 10). * Underwriters' Laboratories listed and Factory Mutal approved 3/4" to 8" sizes only.

ORDERING: Specify pipe size and figure number.

Fig. 153

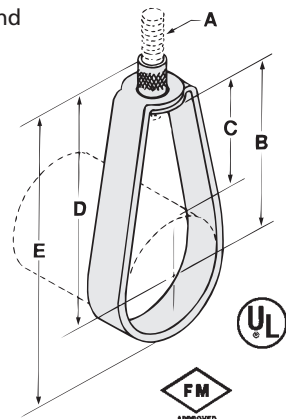

MATERIAL: Low carbon steel

FINISH: Pre-galvanized with PVC Coating

Pipe Size	Rod Size A	B	Adj. C	D	E	Max. Rec. Load/lbs.	Wt. Each (in lbs.)
1/2	3/8	1 7/8	1 1/16	2 3/4	3 1/16	300	.11
3/4	3/8	1 11/16	1 1/8	2 1/2	3 1/16	300	.13
1	3/8	1 5/8	1	2 1/2	3 3/16	300	.13
1 1/4	3/8	1 5/8	1 1/16	2 13/16	3 9/16	300	.15
1 1/2	3/8	2 1/8	1 1/16	3 1/8	3 7/8	300	.17
2	3/8	2 7/16	1 1/8	3 5/16	4 3/8	300	.18
2 1/2	1/2	2 3/4	1 1/4	3 11/16	5 1/8	600	.34
3	1/2	3 1/8	1 1/8	4	5 7/8	600	.39
3 1/2	1/2	3 5/8	1 1/2	4 5/16	6 5/8	600	.42
4	5/8	3 7/8	1 1/4	4 15/16	7 1/8	1000	.48
5	5/8	4 3/8	1 3/8	5 5/8	8 1/2	1000	.69
6	3/4	5 1/16	2	6 11/16	10 1/8	1250	1.13
8	3/4	6 15/16	2 5/8	8 5/16	12 7/8	1250	1.29

SAFETY PRODUCTS

TOOLS & ACCESSORIES

CONTRACTOR SUPPLIES

HANGERS & STRUT

FASTENERS & THREADED ROD

CONCRETE ANCHORS

SPECIALTY ITEMS SERVICES & DATA