

Regal Star Series



RSM/L 500/600/750/850/1005/1105 Installation, Operation and Maintenance Manual

Keep these instructions with the furnace at all times
for future reference



Boyertown Furnace Co.
PO Box 100
Boyertown, PA 19512
610-369-1450
www.boyertownfurnace.com

OFC-5000
Nidec
PerfectSpeed®

8-29-24

Be Aware of Hazard Definitions

Danger

Denotes presence of a hazard which, if ignored, will result in severe personal injury, death or property damage

Warning

Denotes presence of a hazard which, if ignored could result in severe personal injury, death or substantial property damage.

Caution

Denotes the presence of a hazard, which if ignored, could result in minor personal injury or property damage

Notice

Intended to bring attention to information, but not related to personal injury or property damage.

Danger

This equipment must be installed, adjusted and started only by a qualified service agency – an individual or agency, licensed and experienced with all codes and ordinances, and who is responsible for the installation and adjustment of the equipment. **THE INSTALLATION OF THE EQUIPMENT SHALL BE IN ACCORDANCE WITH THE REGULATION OF AUTHORITIES HAVING JURISDICTION AND CSA STANDARD B139 AND OR NFPA 31**

Read all instructions before proceeding. Follow all instructions completely. Failure to follow these instructions could result in equipment malfunction causing severe personal injury, death or substantial property damage.

DO NOT TAMPER WITH THE UNIT OR CONTROLS – CALL YOUR SERVICEMAN. The manufacturer will not be liable for any damage resulting from changes made in the field to the furnace or its components or from improper installation. Failure to comply could result in severe personal injury, death, or substantial property damage.

DO NOT USE WITH OILS HEAVIER THAN NO. 2. NEVER USE GASOLINE, CRANKCASE OIL, OR ANY OIL CONTAINING GASOLINE. Your oil-fired furnace is designed to burn No. 1 and No. 2 heating oil only.

DO NOT START THE BURNER UNLESS THE BLOWER ACCESS DOOR IS SECURED IN PLACE.

Do not store gasoline or other flammable vapors and liquids in the vicinity of this or any other appliance.

The area around the furnace should be kept free and clear of combustible materials.

NEVER BURN GARBAGE OR REFUSE IN THE HEATING SYSTEM, AND NEVER LEAVE PAPER OR RAGS AROUND THE UNIT.

Never try to ignite oil by tossing burning papers or other material into your furnace.

DO NOT ATTEMPT TO START THE BURNER WHEN EXCESS OIL HAS ACCUMULATED OR THE FURNACE IS FULL OF VAPORS OR WHEN THE COMBUSTION CHAMBER IS VERY HOT.

Do not use the furnace as a construction heater.

Do not operate furnace if the heat exchanger is damaged. Toxic flue products could enter air stream.

Do not jumper, attempt to bypass or override any of the safety limit controls.

Do not use this furnace if any part has been under water. Immediately call a qualified service technician to inspect the furnace and replace any part of the furnace, control system or burner that has been under water.

Do not operate furnace if temperature rise through the heat exchanger exceeds that which is listed on the Ratings Label.

Do not operate furnace without return air properly sized or ducted.

NOTICE

Concealed Damage- If you discover damage to the burner, furnace or controls during unpacking, notify the carrier at once and file the appropriate claim. When calling or writing about the furnace please have the following information available: the furnace model number and serial number which is located on the upper portion of the front of the unit. Record the model and serial number for future reference in the space provided in this manual.

TABLE OF CONTENTS	PAGE NO.
FURNACE SPECIFICATIONS	4
INSTALLATION CLEARANCES Standard Clearances Reduced Clearances	6
DUCT WORK Sizing Blower Specifications Filter Racks	8
Hydrolevel OFC-5000	11
MOTORS	15
VENTING Direct Venting Chimney Venting Chimney Relining Chimney Connector Power Venting Vent Dampers	21
VENTILATION AND COMBUSTION AIR	24
BURNER INSTALLATION	25
WIRING Power Thermostat	26
OIL TANK AND PIPING	36
START UP Start Up Equipment Burner Adjustments	38
OPERATING AND MAINTENANCE Cleaning the Furnace Oil Burner Blowers – Direct Drive Vent System Fuel Oil System Filters	40
PARTS BREAKDOWN LISTS	42
TROUBLE SHOOTING GUIDE	44
WARRANTY	50
INSTALLATION AND SERVICE CHECKLIST	51
WARRANTY REGISTRATION	54

Specifications

RSM

	RSM 500	RSM 600	RSM 750	RSM 850	RSM 1005	RSM 1105
Firing Rate (GPH)	0.50	0.60	0.75	0.85	1.00	1.10
Input (Btu/Hr)	70,000	84,000	105,000	119,000	140,000	154,000
Heating Capacity (Btu/Hr)	60,000	72,000	89,000	102,000	118,000	130,000
Temperature Rise	60°F	60°F	60°F	60°F	60°F	60°F
Flue Size (Inches)	5	5	5	5	5	5
Filter Size (Inches)	16 x 20 x 1	16 x 20 x 1	16 x 20 x 1	16 x 25 x 1	16 x 25 x 1	16 x 25 x 1
Motor PSC	¾ HP – 3 Spd 10.0 FLA	¾ HP – 3 Spd 10.0 FLA	¾ HP – 3 Spd 10.0 FLA	¾ HP – 4 Spd 11.0 FLA	¾ HP – 4 Spd 11.0 FLA	Available ECM Only
Motor ECM	¾ HP – Var 9.4 FLA	¾ HP – Var 9.4 FLA	¾ HP – Var 9.4 FLA	1 HP – Var 12.0 FLA	1 HP – Var 12.0 FLA	1 HP – Var 12.0 FLA

RSML

	RSML 500	RSML 600	RSML 750	RSML 850	RSML 1005	RSML 1105
Firing Rate (GPH)	0.50	0.60	0.75	0.85	1.00	1.10
Input (Btu/Hr)	70,000	84,000	105,000	119,000	140,000	154,000
Heating Capacity (Btu/Hr)	60,000	72,000	89,000	102,000	118,000	130,000
Temperature Rise	60°F	60°F	60°F	60°F	60°F	60°F
Flue Size (Inches)	5	5	5	5	5	5
Filter Size (Inches)	20 x 20 x 1	20 x 20 x 1	20 x 20 x 1	20 x 20 x 1	20 x 20 x 1	20 x 20 x 1
Motor PSC	¾ HP – 3 Spd 10.0 FLA	¾ HP – 3 Spd 10.0 FLA	¾ HP – 3 Spd 10.0 FLA	¾ HP – 4 Spd 11.0 FLA	¾ HP – 4 Spd 11.0 FLA	Available ECM Only
Motor ECM	¾ HP – Var 9.4 FLA	¾ HP – Var 9.4 FLA	¾ HP – Var 9.4 FLA	1 HP – Var 12.0 FLA	1 HP – Var 12.0 FLA	1 HP – Var 12.0 FLA

Dimensions

	RSM 500/600/750	RSML 500/600/750	RSM 850/1005/1105	RSML 850/1005/1105
Cabinet Height - A	44-9/16"	31-5/16"	50-3/8"	33-1/4"
Cabinet Width - B	22-5/16"	22-5/16"	22-5/16"	22-5/16"
Cabinet Depth - C	23-3/8"	43-1/8"	28-3/8"	48-1/4"
Flue Height Front - D	40"	26-13/16"	46-7/8"	29-5/8"
Flue Height Rear - E	40"	26-13/16"	45"	27-3/4"
Burner Height - F	27-1/2"	14-1/16"	31"	13-13/16"
Supply Air Depth - G	22-3/8"	22-3/8"	27-3/8"	27-3/8"
Supply Air Width - H	21-1/16"	21-1/16"	21-1/16"	21-1/16"
Return Air Depth - I	15-1/16"	17"	23-5/8"	17"
Return Air Width - J	18-7/8"	21-1/16"	15"	21-1/16"

RSM Highboy Configuration

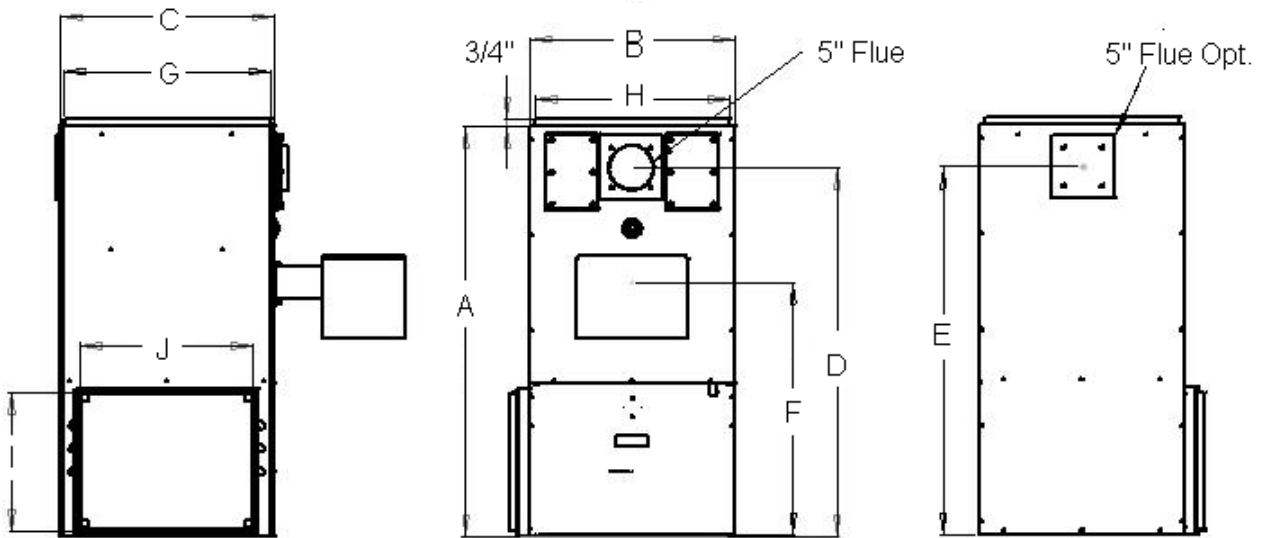

RSM Horizontal Configuration

Left- or Right-Hand Discharge Permitted
Rotate Burner Accordingly

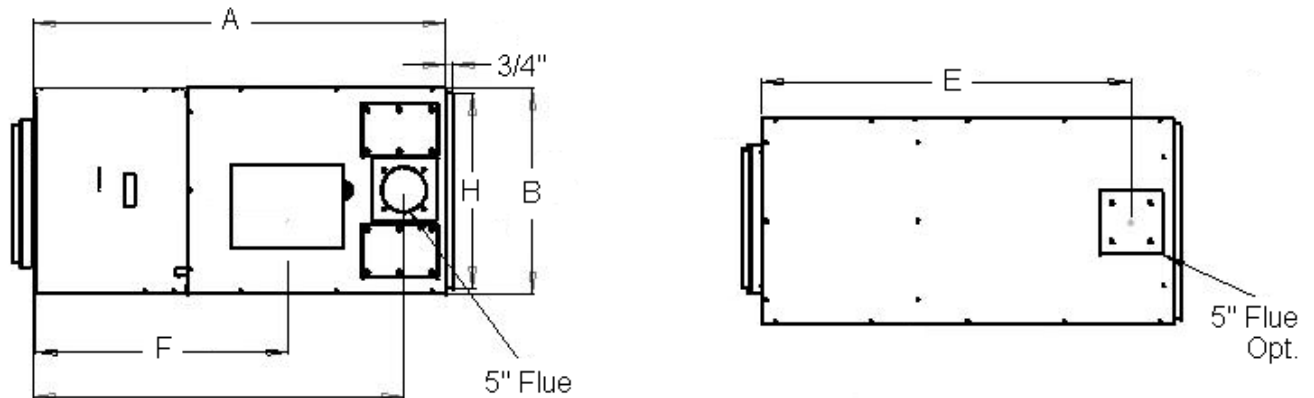

RSML

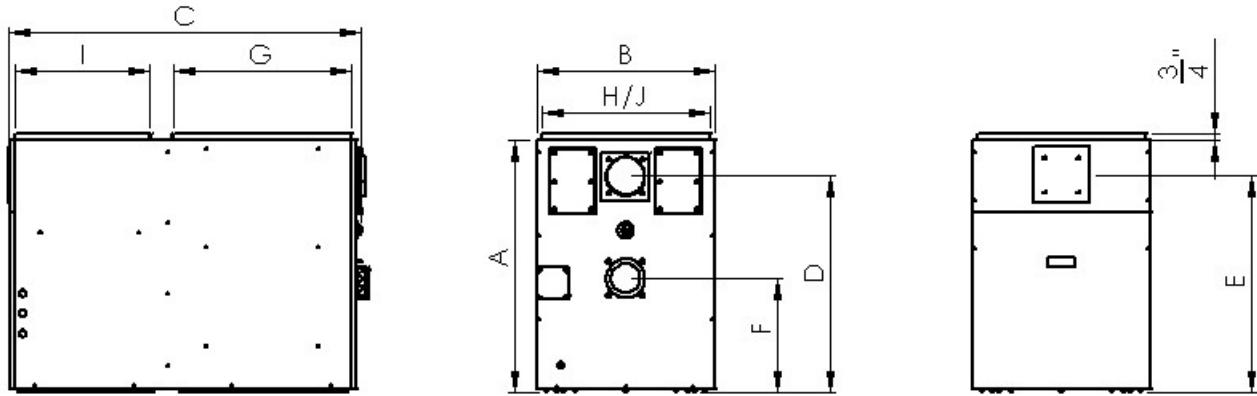

Installation Clearances

WARNING Furnaces in rooms shall be installed with the clearances from combustible materials not less than indicated in Table 1. Combustible materials are those made of or surfaced with wood, compressed paper, plant fibers, plastics, or other material that will ignite and burn, whether flame proofed or not, or whether plastered or not.

Place the furnace near the center of the supply and return ducts and as close to the chimney connector as possible. Provide a solid brick or 2" thick minimum concrete pad if the furnace mounting area is not level or if the floor can become flooded.

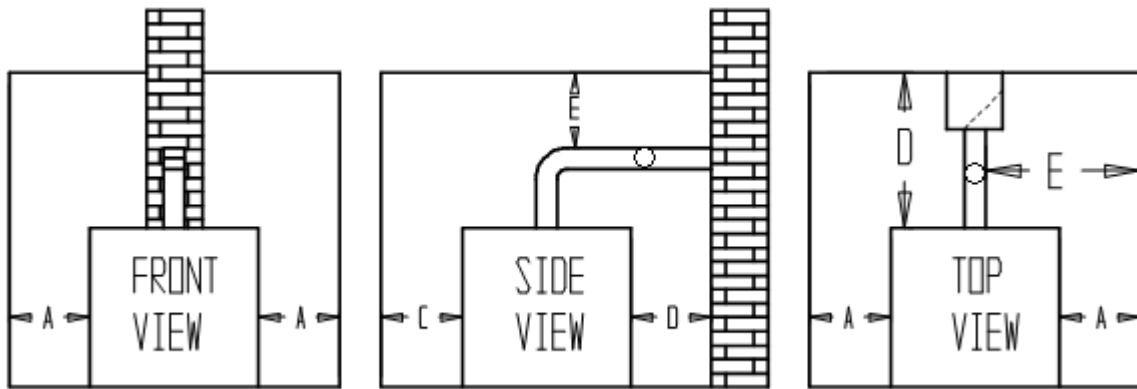

Table 1a: Standard Installation Clearances

MODEL	Sides "A"	Top "B"	Front "C"	Rear "D"	Flooring	Chimney Connector "E"	Plenum Top & Sides
RSM 500/600/750	2"	2"	Closet-18"	6"	Combustible	6"	2"
RSML 500/600/750	2"	2"	24"	6"	Noncombustible	6"	2"
RSM 850/1005/1105	2"	2"	Closet-18"	6"	Combustible	6"	2"
RSML 850/1005/1105	2"	2"	24"	6"	Noncombustible	6"	2"

Table 1b: Standard Installation Clearances Horizontal Configuration

MODEL	Sides "A"	Top "B"	Front "C"	Rear "D"	Flooring	Chimney Connector "E"	Plenum Top & Sides
RSM 500/600/750	2"	2"	Closet-18"	6"	Noncombustible	6"	2"
RSM 850/1005/1105	2"	2"	Closet-18"	6"	Noncombustible	6"	2"

Furnaces are permitted to be installed in rooms, but not in alcoves or closets, with lesser clearances to combustible material, provided the combustible material is protected as described in Table 2 and NFPA 31. In no case shall the clearances be such as to interfere with the requirements for combustion air, draft regulators and accessibility.

All clearances shall be measured from the outer surface of the combustible material to the nearest point on the surface of the appliance or chimney connector, disregarding any intervening protection applied to the combustible material.

Spacers and ties are to be of noncombustible material. No spacer or tie shall be used directly opposite an appliance or chimney connector.

With all clearance reduction systems using ventilated air space there shall be at least 1” clearance between the reduction systems using ventilated air space.

Mineral wool batts, blanket or board shall have a minimum density of 8lb/ft³ and a minimum melting temperature of 1500⁰F.

Insulation material used as part of a clearance reduction system shall have a thermal conductivity of 1.0(Btu/In)/ (Ft²/Hr/⁰F).

Type of protection applied to and covering all surfaces within the distance specified as the required clearance with no protection	Table 2: Allowable Clearances with Specified Protection Where the Specified Clearance with No Protection from the Appliance or Chimney Connector							
	18”		12”		9”		6”	
	Above	Rear & Sides	Above	Rear & Sides	Above	Rear & Sides	Above	Rear & Sides
3½” thick masonry wall without ventilated air space	N/A	12”	N/A	9”	N/A	6”	N/A	5”
½” insulation board over 1” glass fiber or mineral wool batts	12”	9”	9”	6”	6”	5”	4”	3”
24 gauge sheet metal over 1” glass fiber or mineral wool batts reinforced with wire on rear face with ventilated air space	9”	6”	6”	4”	5”	3”	3”	3”
3½” thick masonry wall with ventilated air space	N/A	6”	N/A	6”	N/A	6”	N/A	6”
24 gauge sheet metal with ventilated air space	9”	6”	6”	4”	5”	3”	3”	2”
½” insulation board with ventilated air space	9”	6”	6”	4”	5”	3”	3”	3”
24 gauge sheet metal with ventilated air space over 24 gauge sheet metal with ventilated air space	9”	6”	6”	4”	5”	3”	3”	3”
1” glass fiber or mineral wool batts sandwiched between 2 sheets 24 gauge sheet metal with ventilated air space	9”	6”	6”	4”	5”	3”	3”	3”

If the furnace is to be installed in a residential garage, the furnace must be a minimum of 18” above the garage floor and located so it cannot be damaged by a moving vehicle.

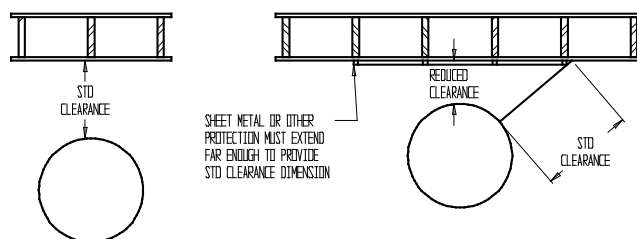

Duct Work

NOTICE

The duct system should follow the design standards of Air Conditioning Contractors of America (ACCA) or ASHRAE. The duct system should be sized for the maximum CFM capabilities of the furnace being installed.

All trunk lines, take-offs, registers and grill free areas must be figured when determining the air handling capacity of a duct system. By utilizing the Tables 3 through 5, one can obtain the necessary duct system size. Use a supplier's catalog for proper sizing of outlet and return air registers to insure that the register will meet the CFM requirements of the run to which it is connected. Do not exceed the recommended flow rate. The pressure drop for each should not exceed 0.05 inch water column.

The return air ducts should equal the warm air duct system in CFM capacities. Avoid locating a return air duct in rooms that may contain undue odors. Use only the supplied return air filter mounted to the furnace. Do not add additional filters unless the duct system is sized to allow for the additional pressure drop. **An open return in a basement does not meet the requirements of return air. Instruct the homeowner not to block any returns.**

Always check the size of existing ducts, particularly if you are adding air conditioning. The pressure drop through the cooling evaporator coil reduces available air flow. If the ducts are too small the system may not work satisfactorily or be noisy on either heat or cooling. **If necessary, build a transition to duct work or coil box. Do not fold over flanges or block off supply/return openings, doing so will reduce airflow.**

If the furnace is used in connection with summer air conditioning, the furnace should be installed parallel with or on the upstream side of the evaporator coil to avoid condensation in the furnace heat exchanger. **The evaporator coil must be installed at least 6" above the heat exchanger for proper air flow. Distances less than 6" will result in decreased air flow.** In all cases refer to the manufacturers data for static pressure losses to ensure the total system static pressure does not exceed 0.5" WC. If the cooling unit is installed with a parallel flow arrangement, dampers or other means used to control flow of air should be provided to prevent chilled air from entering the furnace. If such a damper is manually operated, it must be equipped with a means to prevent operation of either unit, unless the damper is in the full heat or cool position.

NOTE: When a return register is located in the same room as the furnace, the register must be at least 20 feet away from the furnace.

On a direct drive unit, the blower motor speed may need to be changed depending upon the size of the air conditioning system installed and the static resistance of the duct system. See blower specifications for air conditioning CFM at 0.5" WC static pressure.

Determining Air Flow CFM

The temperature rise through the furnace should not exceed the rated temperature rise as listed on the Rating Label (Typically 75°F) and should be at least 55°F for comfort.

The sensible heat temperature change for cooling would be approximately 30°F. Actual temperature change will be approximately 20°F due to the humidity in the air.

To calculate the sensible heat change or temperature rise the following formula applies

$$\Delta T = (\text{Btu/Hr} - \text{Output}) / (1.1 \times \text{CFM})$$

To calculate the air flow when you know the temperature rise the following formula applies

$$\text{CFM} = (\text{Btu/Hr} - \text{Output}) / (1.1 \times \Delta T)$$

An estimate of air flow can be achieved by the following rules of thumb:

Heating: 1300 CFM per 100,000 Btu/Hr output

Cooling: 400 CFM per ton of air conditioning

Determine the required air flow for the system based on both heating and cooling requirements. Use the larger of either for duct design.

Table 3 lists the maximum recommended air velocities for ducts. Velocities greater than those as listed may result in objectionable air noise in the ducts.

Application	Main Ducts*		Branch Ducts	
	Supply	Return	Supply	Return
Apartments	900	700	600	600
Auditoriums	1200	1000	1000	800
Banks	2000	1500	1600	1200
Hotel Rooms	1500	1300	1200	1000
Libraries	2000	1500	1600	1200
Meeting Rooms	2000	1500	1600	1200
Offices	2000	1500	1600	1200
Residences	900	700	600	600
Restaurants	2000	1500	1600	1200
Retail Stores	2000	1500	1600	1200

*When sound control is critical use branch duct velocities

CFM	Area Sq. In. 600FPM	Area Sq. In. 800FPM	Area Sq. In. 1000FPM	Area Sq. In. 1200FPM	Area Sq. In. 1600FPM	Area Sq. In. 2000FPM
50	12					
100	24	18	14	12		
150	36	27	22	18	14	
200	48	36	29	24	18	14
250	60	45	36	30	23	18
300	72	54	43	36	27	22
400	96	72	58	48	36	29
500	120	90	72	60	45	36
750	180	135	108	90	68	54
1000	240	180	144	120	90	72
1250	300	225	180	150	113	90
1500	360	270	216	180	135	108
1750	420	315	252	210	158	126
2000	480	360	288	240	180	144

Note: For Systems not over 100 feet equivalent length. Do not apply this table to duct systems which exceed 100 equivalent feet in length. For longer systems refer to ACCA Manual D. Incorrectly sized ducts can result in unsafe or uncomfortable operation.

Nominal Size	4	5	6	7	8	9	10	12
Area in. ²	12.5	19.6	28.3	38.5	50.3	63.6	78.5	113.1

FILTER RACK

An external filter rack has been provided for ease of installation on RSM models. Square knock outs are located on either side when using the furnace in a highboy configuration. The return can also be ducted into the rear of the unit in the highboy configuration. Square knockouts are provided in the galvanized pan when using in the horizontal configuration. The RSML models have internal filter brackets already installed within the blower compartment.

AIR FILTERS

To maintain furnace performance and safety, inspect filters monthly during the heating or cooling season and replace if dirty. Use new approved disposable filters of the same size and type, or clean permanent filters according to the manufacturer's instructions. Replace or clean the filter more often if dusty conditions exist. Dirty, clogged or wrongly sized filters will impair the furnace performance and may cause the furnace to shut down or overheat.

MULTIPLE FURNACES IN COMMON DUCT WORK

Multiple furnaces connected to common duct work, either supply, return, or both supply and return must be wired so that all furnace blower motors are energized at the same time. Failure to turn all blowers on at the same time can cause a reversal of air flow in those units where the blower motor is not operating. This reversal of air flow can cause premature blower, blower motor, wiring and or heat exchanger failure.

PLEASE CONSULT THE FACTORY FOR SPECIFIC WIRING INSTRUCTIONS FOR YOUR APPLICATION.

HYDROLEVEL COMPANY

OFC-5000 Oil Furnace Fan Speed Control and Temperature Limit

Selectable Motor Control
Options for:

- PSC motors
- ECM motors
(Thermostat control or PWM control)

Installation and Operating Manual

OFC-5000 Kit Includes:

- Controller Board
- Mounting Bracket
- 2 Long Screws
- 2 Short Sheet Metal Screws
- 2 Short Coarse Thread Screws
- Installation and Operating Instructions

NOTICE Read these instructions completely before proceeding with the installation. Retain instructions for future reference.

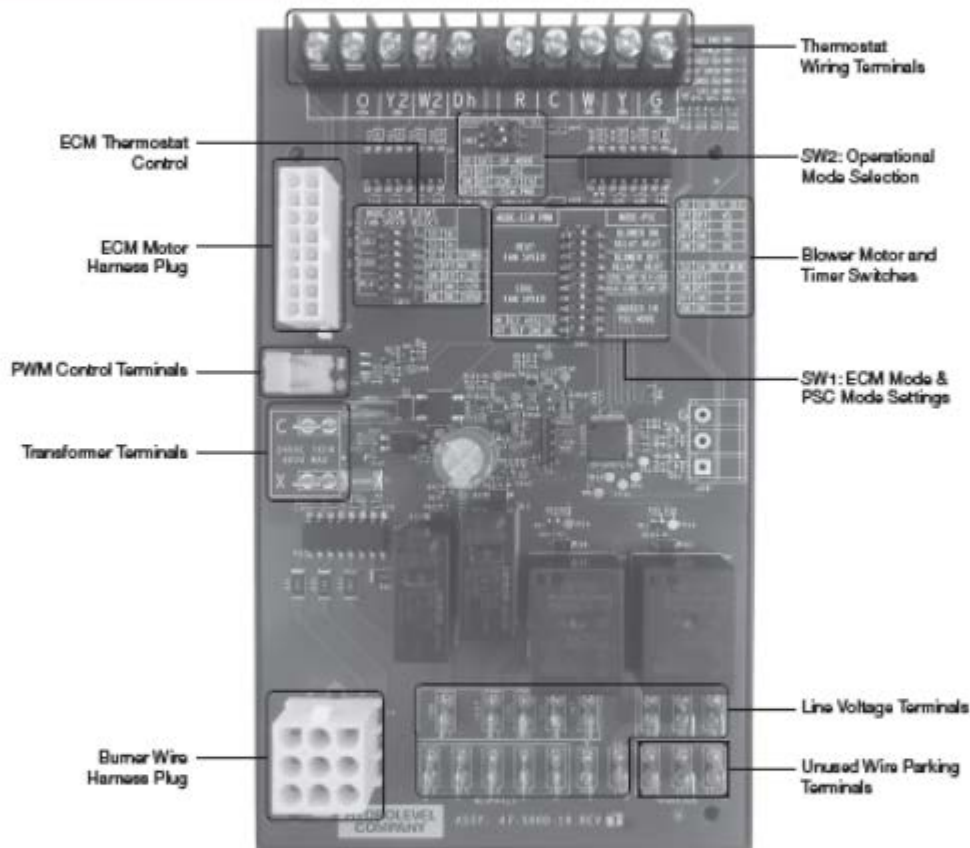

WARNING Electrical shock hazard. To prevent electrical shock, death or equipment damage, disconnect power supply before installing or servicing control. Only qualified personnel may install or service this control in accordance with local codes and ordinances. Read instructions completely before proceeding.

CAUTION To prevent serious burns, furnace should be thoroughly cooled before installing or servicing control.

WARNING Frozen pipes/water damage. Central heating systems are prone to shut down as a result of power or fuel outages, safety related fault conditions or equipment failure. Installation of freeze protection monitoring or other precautions is recommended for unattended dwellings in climates subject to sustain below-freezing temperatures.

**HYDROLEVEL
COMPANY**

126 Bailey Road • North Haven, CT 06473 • (203) 776-0473 • FAX (203) 764-1711 • www.hydrelevel.com

REPLACING AN EXISTING CONTROL BOARD

NOTE: Prior to replacing the existing controller, note the DIP switch settings and the location of all wires. Taking pictures is a good way to preserve the existing wiring and setup information for future reference.



WARNING Electrical shock hazard. To prevent electrical shock, death or equipment damage, disconnect power supply before installing or servicing control. Only qualified personnel may install or service this control in accordance with local codes and ordinances.

STEP 1: Remove the existing controller

1. Turn off power.
2. Note the DIP switch settings and the location of all wires on the original controller.
3. Remove the wire harnesses from the existing control board.
4. Remove the control board assembly from the furnace.

STEP 2: Install the mounting bracket and the new control board.

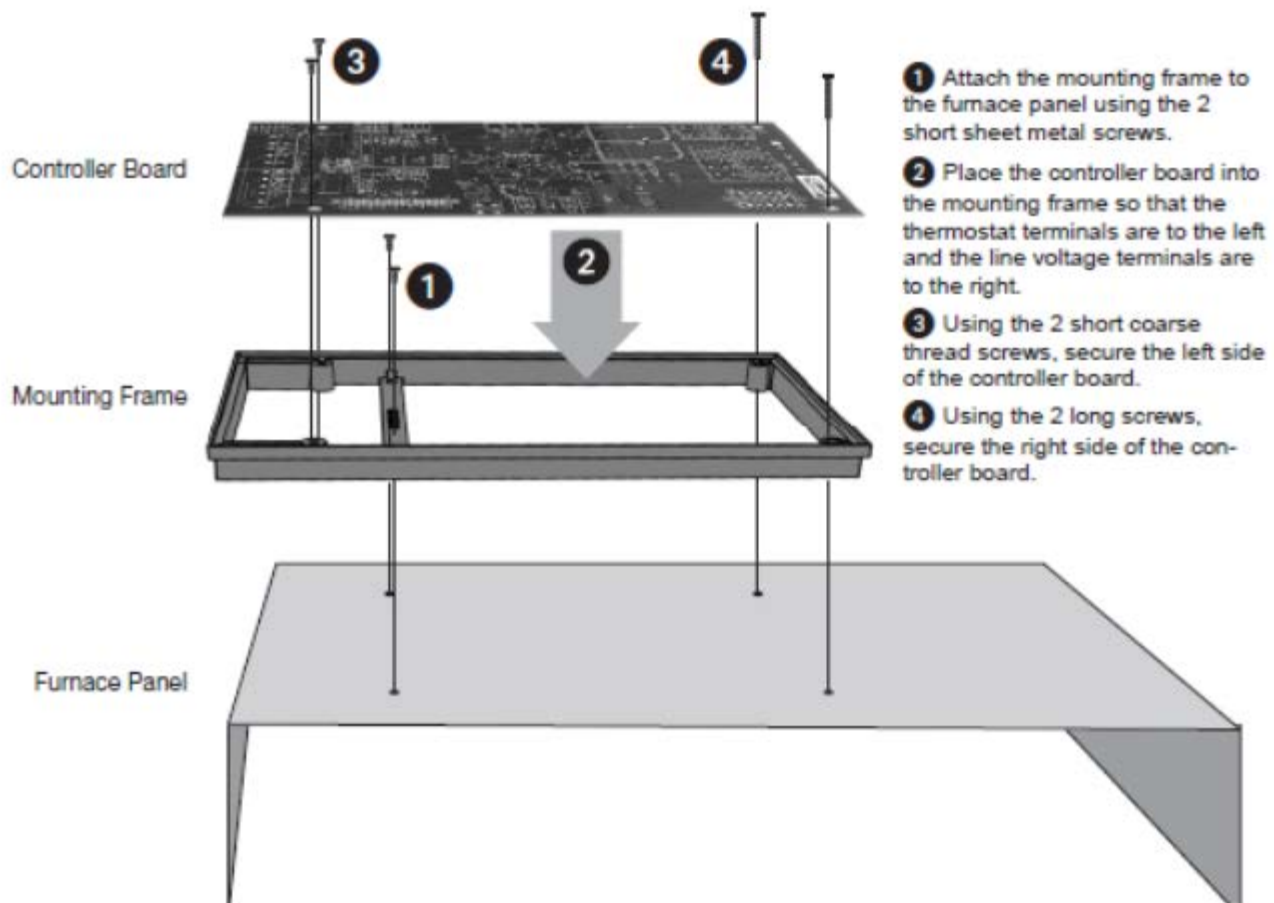

STEP 3: Plug in the wire harnesses in the same locations as the original control. **NOTE:** For proper wiring and setup consult the furnace manufacturer's installation manual.

SETUP

Refer to furnace manufacturer's Installation and Operating Manual for required settings.
See page 1 for location of DIP switches on circuit board.

1. Configure SW2 to select the blower motor type:
PSC, ECM-Thermostat, ECM-PWM.
2. Proceed to the selected motor setup section.



Operational Mode Select

S1	S2	Operating Mode
Off	Off	PSC
On	Off	ECM-TStat
Off	On	ECM-PWM
On	On	Unused

PSC Mode

Configure SW1 for blower motor on/off delays. The bottom four switches (7-10) are not used.

Mode = PSC Blower Settings

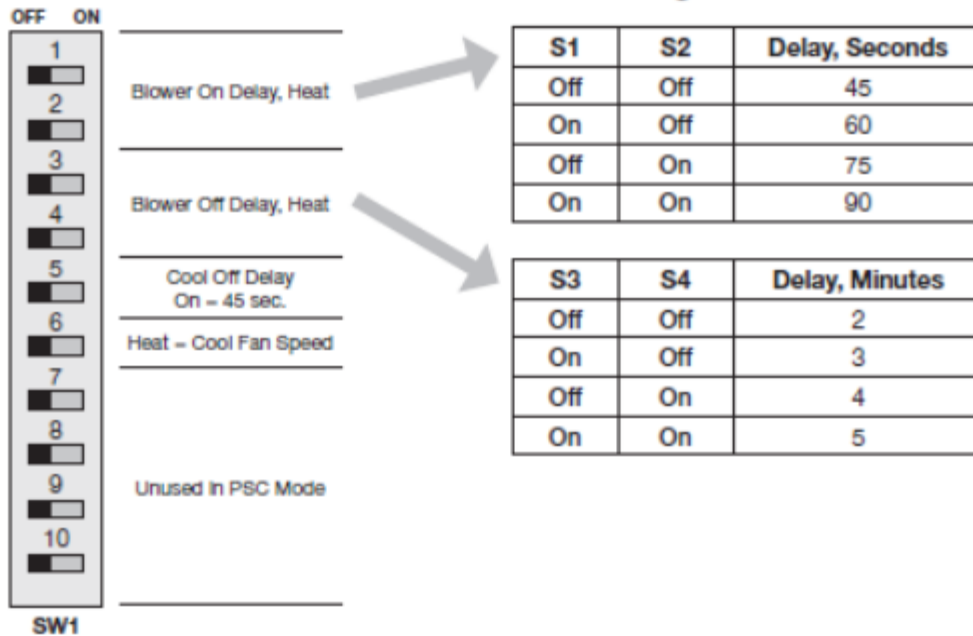

ECM-Thermostat Control

Configure SW3 for blower speed control.

In thermostat control mode the control passes through all thermostat inputs to the ECM motor. The ECM motor controls all the blower speed logic.

Mode = ECM T-Stat Fan Speed Select

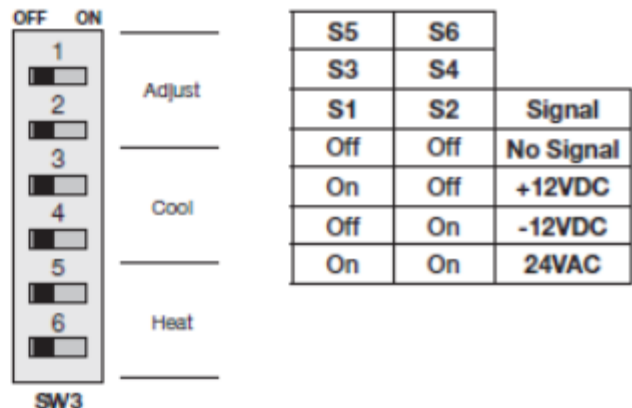

ECM MOTOR OPERATING MODES

Introduction

The ECM motor is a variable speed, high efficiency motor which has the ability to produce constant air flow within a system, independent of static pressure. It achieves constant air flow by adjusting speed and torque to account for changes in system static pressure.

Operating Modes

The ECM motor is controlled by 24VAC thermostat signals to determine which mode of operation the blower is to run. Air flow rates in the different modes are controlled by the setting of the DIP switches in the Hydrolevel OFC-5000.

Standby Mode:

The thermostat inputs are being continuously monitored by the Nidec 16 x 4 Wire Box. The motor will respond to the 24 volt AC input signal from the thermostat.

Fan Mode:

When a call for fan operation is received from the thermostat (“G” line is energized) the blower will operate at a reduced speed as determined by the position of the cooling DIP switches as set for the air conditioning speed. See air flow tables for DIP switch and air flows. If a call for cooling or for heating is energized along with the call for fan only the unit will run at the respective air flow for heating or cooling. Electronic air cleaner terminal “EAC” is energized

Cooling Mode:

When a call for cooling is received from the thermostat (“Y” line is energized) the motor will operate at the cooling speed and profile as adjusted by the cooling DIP switches. Cooling air flow is profiled to ramp the air flow up to the full cooling air flow to allow for maximum dehumidification. Electronic air cleaner terminal “EAC” is energized

Heat Mode:

When a call for heat is received from the thermostat (“W” line is energized) the motor will operate through the heating cycle at the air flow as adjusted by the heating DIP switch. When a call for heat is initiated the blower will turn on after a 45 second delay to ensure warm plenum temperatures as the furnace heats up. The electronic air cleaner terminal “EAC” and humidifier terminal “HUM” are energized.

When the call for heat is satisfied the blower will continue to operate for a period of 90 seconds to remove all of the usable heat from the furnace while still maintaining the plenum temperatures at a comfortable level.

ECM Motor Air Flow Selection

Air flow settings for both heating and cooling are made by setting the heat and the cool airflow DIP switches to the proper location. Ensure the furnace power supply is off before adjusting blower speeds. Do not adjust the heating air flow below the firing rate of the furnace. The air flows for heating are designed to give a specified temperature rise.

The operational mode SW2 needs to be set to ECM – Tstat mode by setting S1 to “ON” and S2 to “OFF”.

RSM/L 500/600/750 Cooling Speed Selection					
AC Tons	Cool Switch#3 Position	Cool Switch#4 Position	Air Flow CFM Y2	Air Flow CFM Y1	Air Flow CFM G
4 Tons	OFF	OFF	1600	1200	800
3 Tons	ON	OFF	1200	900	600
2.5Tons	OFF	ON	1000	750	500
2 Tons	ON	ON	800	600	500

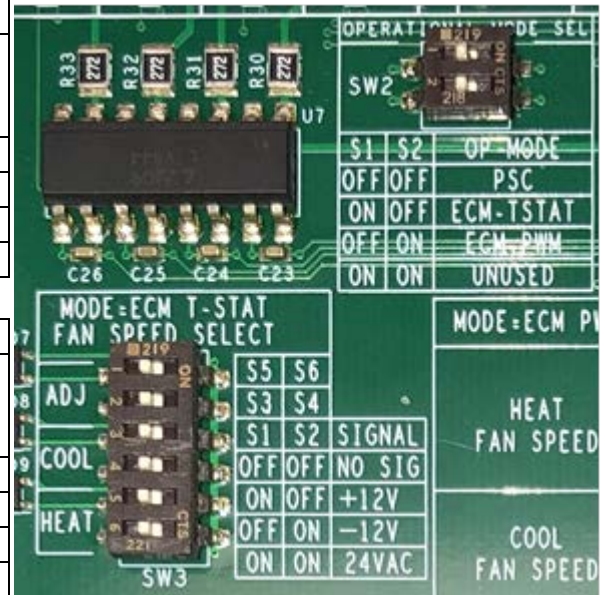

RSM/L 850/1005/1105 Cooling Speed Selection					
AC Tons	Cool Switch#3 Position	Cool Switch#4 Position	Air Flow CFM Y2	Air Flow CFM Y1	Air Flow CFM G
5 Tons	OFF	OFF	2000	1500	1000
4 Tons	ON	OFF	1600	1200	800
3.5Tons	OFF	ON	1400	1050	700
3 Tons	ON	ON	1200	900	600

RSM 500/600/750 Heating Speed Selection				
Installed Nozzle	Firing Rate	Heat Switch #5 Position	Heat Switch #6 Position	Heating Air Flow
0.60 GPH	0.75 GPH	OFF	OFF	1325 CFM
0.50 GPH	0.60 GPH	ON	OFF	1100 CFM
0.40 GPH	0.50 GPH	OFF	ON	850 CFM

RSM/L 500/600/750 Heating Speed Selection				
Installed Nozzle	Firing Rate	Heat Switch #5 Position	Heat Switch #9 Position	Heating Air Flow
0.60 GPH	0.75 GPH	OFF	OFF	1325 CFM
0.50 GPH	0.60 GPH	ON	OFF	1175 CFM
0.40 GPH	0.50 GPH	ON	ON	1000 CFM

RSM/L 850/1005/1105 Heating Speed Selection				
Installed Nozzle	Firing Rate	Heat Switch #5 Position	Heat Switch #6 Position	Heating Air Flow
0.85 GPH	1.10 GPH	OFF	OFF	1950
0.75 GPH	1.00 GPH	ON	OFF	1775
0.65 GPH	0.85 GPH	OFF	ON	1525

ADJ – Adjust selection		
Adjust Switch #1 Position	Adjust Switch #2 Position	Air Flow Change
OFF	OFF	NONE
ON	OFF	+3%
OFF	ON	-3%
ON	ON	Test Only ¹

1. Do not leave in this position for normal operation

ECM Motor Connections

The operation of the motor requires two main connections: the 5-pin power input connector which is 120VAC, as shown in Figure 1 and the 4-pin input signal connector from the 16 x 4 Wire Box as shown in figure 2. When wiring your ECM, the pin locations are crucial in assuring that no damage is done to the motor or the control.



Figure 1

Power Connector	
Pin	Description
1	JUMPER PIN 1 TO PIN 2
2	120 VAC LINE INPUT
3	CHASSIS GROUND
4	AC LINE NEUTRAL
5	AC LINE L1 120VAC

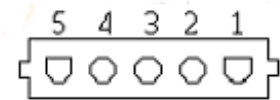

Power Connector

16 x 4 Wire Box Connections

The remote mounted 16 x 4 wire box translates the thermostat and control signals from the Hydrolevel OFC-5000 board into the appropriate air flow signal for the motor. In standby and all operating modes the “RX” and “TX” lights will flash showing communication with the motor. During a call for blower operation the “PW” light will blink showing the air flow requested followed by an off period. Counting the blinks between the off period shows the requested air flow whereby each blink equates to 100 CFM.



Figure 2

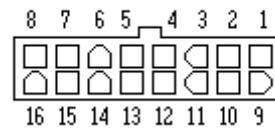

4 pin motor connector

16 Pin Connector

16 Pin Signal Connector							
Pin	Description	Pin	Description	Pin	Description	Pin	Description
1	C1	5	COOL	9	O	13	W2
2	W/W1	6	Y1	10	BK	14	Y/Y2
3	C2	7	ADJUST	11	HEAT	15	G
4	DELAY	8	OUT	12	R	16	OUT

PSC Motor Air Flow

The operational mode SW2 needs to be set to PSC mode by setting S1 to “OFF” and S2 to “OFF”.

Heating – set the blower motor speed to give the specified air temperature rise. Fan on time after the burner starts is fixed by the Hydrolevel OFC-5000 control at 45 seconds. Fan times can be adjusted by using the delay DIP switches to regulate the outlet air temperature at the end of a heating cycle. During a call for heat the electronic air cleaner terminal “EAC” and the humidifier terminal “HUM” are energized.

Cooling – set the blower speed to give the required cooling tonnage. Blower starts immediately upon call for cooling. During a call for cooling the electronic air cleaner terminal “EAC” is energized. Blower stops immediately after cooling demand is satisfied.

Continuous fan – By attaching a blower motor speed lead to the continuous terminal “CONT” the blower will run continuously at that speed until there is a call for heat or cooling.

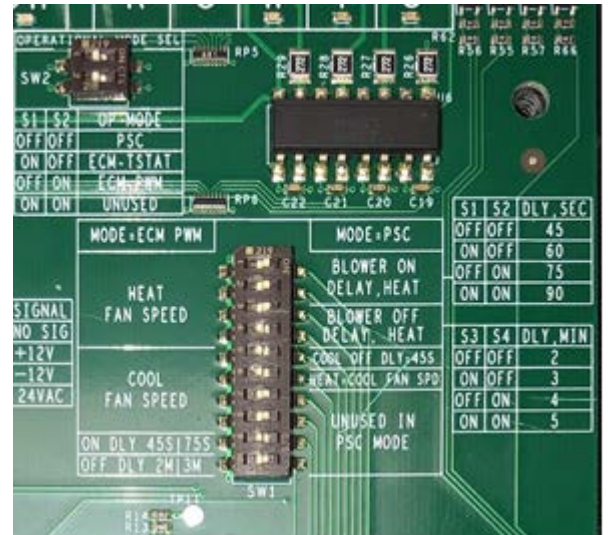

Blower Off Delay - Blower off delay after a call for heat is adjusted through the Delay Blower Off dip switches on the Hydrolevel OFC-500 board. The factory setting is 3 minutes but may be changed to 2, 4, or 5 minutes.

Blower Delay On Settings		
Delay S1	Delay S2	Blower On Delay
OFF	OFF	45 Seconds
ON	OFF	60 Seconds
OFF	ON	75 Seconds
ON	ON	90 Seconds

DELAY-Blower Off		
Delay Switch #3 Position	Delay Switch #4 Position	Blower Off Delay
OFF	OFF	2 Minutes
ON	OFF	3 Minutes
OFF	ON	4 Minutes
ON	ON	5 Minutes

Table 7 Direct Drive Blower Specifications - Nidec PSC Motor										
Model	HP	Speeds	RPM	Volts	Full Load Amps	Capacitor 370 Volt (MFD)	Rotation	Blower Model	Blower Speed AC	Blower Speed Heat
RSM/L 500	3/4	3	1075	115	10.0	15	CCW	100-10T	Hi	Low
RSM/L 600	3/4	3	1075	115	10.0	15	CCW	100-10T	Hi	Low
RSM/L 750	3/4	3	1075	115	10.0	15	CCW	100-10T	Hi	Med
RSML 850	3/4	4	1075	115	11.0	15	CCW	110-9	Hi	Med Low
RSM 850	3/4	4	1075	115	11.0	15	CCW	110-9	Hi	Med Hi
RSM/L 1005	3/4	4	1075	115	11.0	15	CCW	110-9	Hi	Med Hi

RSM 500/600/750						
Nidec PSC Motor Air Flow vs. Static Pressure						
Motor Speed	0.2" Static Press.	0.3" Static Press.	0.4" Static Press.	0.5" Static Press.	0.6" Static Press.	0.7" Static Press.
Low	1193	1175	1152	1125	1090	1053
Med	1425	1375	1310	1256	1190	1118
High	1616	1575	1525	1470	1395	1309

RSML 500/600/750						
Nidec PSC Motor Air Flow vs. Static Pressure						
Motor Speed	0.2" Static Press.	0.3" Static Press.	0.4" Static Press.	0.5" Static Press.	0.6" Static Press.	0.7" Static Press.
Low	1242	1239	1219	1196	1140	1076
Med	1563	1520	1459	1402	1315	1190
High	1703	1648	1568	1475	1368	1259

RSM 850/1005						
Nidec PSC Motor Air Flow vs. Static Pressure						
Motor Speed	0.2" Static Press.	0.3" Static Press.	0.4" Static Press.	0.5" Static Press.	0.6" Static Press.	0.7" Static Press.
Low	1235	1230	1225	1220	1215	1210
Med Low	1390	1375	1367	1360	1354	1344
Med High	1761	1736	1710	1680	1644	1614
High	2103	2065	2020	1970	1900	1825

RSML 850/1005						
Nidec PSC Motor Air Flow vs. Static Pressure						
Motor Speed	0.2" Static Press.	0.3" Static Press.	0.4" Static Press.	0.5" Static Press.	0.6" Static Press.	0.7" Static Press.
Low	1289	1284	1279	1273	1265	1247
Med Low	1470	1465	1456	1449	1438	1413
Med High	1878	1845	1827	1794	1753	1701
High	2217	2150	2083	2027	1956	1879

Table 7										
Direct Drive Blower Specifications - Mars PSC Motor										
Model	HP	Speeds	RPM	Volts	Full Load Amps	Capacitor 370 Volt (MFD)	Rotation	Blower Model	Blower Speed AC	Blower Speed Heat
RSM/L 500	3/4	3	1075	115	11.2	15	CCW	100-10T	Hi	Low
RSM/L 600	3/4	3	1075	115	11.2	15	CCW	100-10T	Hi	Low
RSML 750	3/4	3	1075	115	11.2	15	CCW	100-10T	Hi	Low
RSML 850	3/4	3	1075	115	11.2	15	CCW	110-9	Hi	Low
RSML 1005	3/4	3	1075	115	11.2	15	CCW	110-9	Hi	Med

RSM 500/600/750						
Mars PSC Motor Air Flow vs. Static Pressure						
Motor Speed	0.2" Static Press.	0.3" Static Press.	0.4" Static Press.	0.5" Static Press.	0.6" Static Press.	0.7" Static Press.
Low	1674	1568	1521	1443	1364	1321
Med	1752	1703	1621	1549	1459	1375
High	1863	1766	1695	1592	1482	1414

RSML 500/600/750						
Mars PSC Motor Air Flow vs. Static Pressure						
Motor Speed	0.2" Static Press.	0.3" Static Press.	0.4" Static Press.	0.5" Static Press.	0.6" Static Press.	0.7" Static Press.
Low	1582	1545	1466	1403	1348	1283
Med	1682	1607	1519	1478	1395	1325
High	1716	1683	1613	1527	1442	1401

RSML 850/1005						
Mars PSC Motor Air Flow vs. Static Pressure						
Motor Speed	0.2" Static Press.	0.3" Static Press.	0.4" Static Press.	0.5" Static Press.	0.6" Static Press.	0.7" Static Press.
Low	1563	1557	1537	1515	1485	1441
Med	1899	1867	1839	1796	1737	1689
High	2149	2082	2047	1984	1918	1833

MOTOR CONVERSION

The Hydrolevel OFC-500 makes it possible to switch seamlessly between motor types. **The operational mode selector SW2 must be configured for the proper motor type.**

When changing from an ECM motor to PSC motor remove the ECM motor power cable, 16-pin control cable and 4-pin control cable. Attach the PSC motor speed leads to the proper output terminals for heating, cooling and or continuous fan and any unused motor speed wires to the “Unused” terminals. Attach the motor capacitor to the blower housing and connect the motor capacitor to the appropriate motor leads.

When changing from a PSC motor to an ECM motor remove the capacitor wires and all PSC motor speed wires from the Hydrolevel OFC-5000. Attach the 16 x 4 wire box to the blower housing. Plug in the 16-pin control cable to both the Hydrolevel OFC-5000 and the 16 x 4 wire box. Plug in the 4-pin control cable to both the motor and the 16 x 4 wire box. Plug the motor power cable into the motor and attach the green ground wire to the ground screw on the control mounting panel the white wire spade terminal to an open “Neutral” terminal and the black wire spade terminal to an open “120 VAC” terminal.

VENTING

WARNING	Failure to follow all instructions can result in flue gas spillage and carbon monoxide emissions, causing severe personal injury or death. All chimneys must meet the requirements of NFPA 211 and NFPA 31
----------------	--

Direct Vent

The furnace can be direct vented when used in conjunction with the Boyertown Furnace Direct Vent Kit. For complete direct vent application and installation instructions consult the Furnace Direct Vent Kit Z-Flex DVO manual.

Chimney

OIL FIRED APPLIANCES SHALL BE CONNECTED TO FLUES HAVING SUFFICIENT DRAFT AT ALL TIMES TO ENSURE SAFE AND PROPER OPERATION OF THE APPLIANCE. An adequate chimney or venting system is one that is sealed and lined with the capability of producing a -.04" W.C. flue draft and having the capacity to handle the amount of flue gas that is introduced. A chimney with an internal construction of corrosion resistant tile, stainless steel, or some other material that will withstand flue gas temperatures up to 1000⁰F is required.

Masonry and metal chimneys shall be constructed in accordance with applicable building code requirements. Masonry chimneys shall be lined with an approved clay tile liner or a listed chimney lining system installed in accordance with manufacturers' instructions and also meeting the requirements of NFPA-211 Standard for Chimneys, Fireplaces, Vents, and Solid Fuel-Burning Appliances. Metal chimneys also shall meet the requirements of NFPA-211. Factory built chimneys shall be listed and shall be installed in accordance with their listing and NFPA-211.

Prior to installation of the furnace, the chimney or venting system shall be examined by the installer and determined to be in good condition. All joints of the chimney must be tightly sealed. The inside of the chimney should be free of all obstruction, such as loose brick, broken pieces of tile, or corroded metal. If chimney flues are divided or there are multiple flues within one chimney, make sure there are no openings in the partition separating the divided or individual flues. When a new appliance is connected to an existing chimney, that chimney shall be brought up to current requirements. Chimneys which are relined shall be done so with an approved liner that will resist corrosion, softening, or cracking from the flue gasses.

All chimney clean-out doors and flue connections must fit tightly so they will seal to avoid air leakage.

The inside area of the chimney liner should equal, at a minimum, the area of the vent pipe exiting the furnace. If more than one appliance is installed, the area of both appliances shall be used in determining the required inside area of the chimney.

The flue gas exit of a chimney shall be at least 3 feet above the highest point where it passes through the roof of a building and at least 2 feet higher than any portion of a building within 10 feet of such chimney.

The chimney height will also be determined by the height of the surrounding trees, buildings and terrain. When chimney downdraft conditions cause faulty operation that creates a hazard, corrective steps must be taken.

When altering the surrounding obstructions is not possible, a chimney cap can be constructed on the top of the chimney to avoid downdrafts. The chimney cap should be pyramid shaped on the top with a perfectly flat surface immediately above the chimney outlet. The hood should be attached by four (4) iron supports. The four iron supports should be equal in height to the width of the chimney opening.

Four plates, flaring down, can be added to help ensure that the wind will pass straight over the chimney outlet.

Chimney Relining

A tile lined masonry chimney serving an oil-fired furnace should comply with applicable building codes such as NFPA-211. An additional listed lining may be required to reduce transient low draft during startup and acid water condensation during cyclic operation. This is particularly true for high mass masonry chimneys serving oil fired furnaces of higher efficiency. For masonry chimneys, local experience can indicate how well construction has withstood the lower temperatures produced by higher efficiency furnaces.

Evidence of potential or existing chimney damage should be determined by visual inspection of the chimney and liner. Exterior indicators such as missing or loose mortar/bricks, white deposits on the brick or water stains on the interior building walls should be investigated further. The operational flue temperatures for furnaces range from 350°F to 550°F at the outlet of the furnace. These temperatures are further reduced before reaching the chimney due to heat loss through the vent connector and dilution from the draft regulator. The resulting flue gas temperatures may become low enough to form condensation on the chimney liner walls.

To prevent condensation, it is necessary that the internal chimney wall temperature always be kept above the dew point of the flue gasses. If the chimney is a masonry type, it may have to be lined with a flue liner, if the temperature loss is too great for the furnace. A liner will act as an insulator and reduce the flue gas temperature loss. Insulation may be added around the liner for further temperature stability. Refer to NFPA-31 for recommended liner sizing tables as developed by the Oil Heat Vent Analysis Program.

Chimney Connector

The chimney connector pipe between the furnace and chimney shall be of equal diameter as the flue outlet of the furnace. Refer to furnace specifications in this manual for proper size flue pipe for your model furnace. Any reduction in size required for the chimney must be made at the chimney connector. The vent connector pipe must be made of corrosion-resistant steel. The vent connector pipe should be as short as possible and installed so that it has a continuous rise from the furnace to the chimney. Long horizontal vent runs can result in the possibility of condensation in the flue pipe or the chimney. All horizontal runs of vent connector pipe should be pitched upward a minimum of 1/4 inch per foot of run. The horizontal length of the vent pipe connector shall not exceed 10 feet. The chimney connector shall be installed so as to minimize the number of elbows and to avoid sharp turns or other construction features that would create excessive resistance to the flow of flue gasses. Tees may be used in a straight section in conjunction with a barometric draft regulator; however, they must not be used for a 90° turn. No device that will obstruct the free flow of flue gasses shall be installed in the chimney connector. This does not exclude the use of devices specifically designed for the use in chimney connectors such as automatic dampers. The vent pipe should be joined with metal screws and supported by straps. A thimble should be used to connect the vent connector pipe to the chimney so the pipe may be readily removed in case of inspection or replacement.

No chimney connector shall pass through any floor or ceiling. The vent connector pipe must not pass through a combustible wall or partition unless they are guarded at the point of passage by a ventilated metal thimble not less than 12 inches larger in diameter than the connector, on metal or fireclay thimbles adequate protection is provided at the passageway. An acceptable passageway could be either an approved, ventilated metal thimble which is at least 12 inches larger in diameter than the vent connector pipe, or brick work which is at least 8 inches thick constructed into the wall and surrounding the vent connector

Clearances from combustible materials or materials shall be in accordance with the clearances given in Tables 1 or 2. The vent connector pipe should extend only to (and not beyond) the inside wall of the chimney. A thimble should be used to connect the vent connector pipe to the chimney so that the vent connector pipe may be readily removed in case of inspection or replacement.

Connection to the chimney must be made above the bottom of the chimney to avoid blockage. Vent piping should extend just into the chimney far enough to expel flue gasses. Inserting the vent piping too far into the chimney will cause undue obstruction. Use a thimble or a slip joint where vent pipe enters the chimney to allow easy removal for cleaning.

A draft regulator, which is shipped in the blower compartment, must be installed in the vent piping. It should be located at least 24 inches from the furnace, if possible, in either a horizontal or vertical section of the vent pipe. The draft regulator must be installed in the same room as the furnace and in such a manner that there is no difference in pressure between the air in the vicinity to the regulator and the combustion air supply. Ensure that the barometric damper is accessible for adjustment.

With the burner operating, use a draft gauge to adjust the regulator to the proper setting (see instructions enclosed with draft gauge to adjust the regulator to the proper setting). When the burner air supply and draft are properly adjusted, the over-fire draft should be a negative .02" WC.

Two or more oil burning appliances each equipped with a safety control may be permitted to be connected to one common chimney if sufficient draft is available for the safe simultaneous removal of all products of combustion.

If two or more openings are provided into one chimney, they shall be at different levels on the same story of the building, with the smaller appliance entering at the highest possible level consistent with clearances to combustible materials.

Two or more connectors shall not be joined together unless the common connector, manifold and chimney are properly sized. Adequate draft must be available to safely remove all products of combustion simultaneously without leakage, or back flow.

Power Venting

The furnace may be power vented through a side wall by using a listed power side wall Venter. The vent device must be able to produce a draft of -.02" WC over the fire and be equipped with a post purge timer set to a minimum time of 5 minutes. The power vent must be installed in accordance with the recommendations of the manufacturer, all applicable building code requirements, and NFPA-31.

Vent Dampers

Do not install a thermal type vent damper on the furnace. Failure to comply could result in severe personal injury, death or substantial property damage. If a vent damper is required, use only a motorized damper, wired and installed following the vent damper manufacturer's instructions.

Blocked Vent Switch

Furnaces installed in a chimney require a blocked vent shut-off system when installed in Canada. A safety switch is provided on those units shipped to Canada to perform this function. It is the installer's responsibility to install the switch in accordance with the instructions provided by the manufacturer.

The blocked vent switch is a safety device for detecting the spillage of flue gases due to inadequate draft or a blocked flue. NEVER RESET THE SWITCH UNLESS THE CAUSE OF THE BLOCKAGE HAS BEEN CORRECTED.

RSML Rear Flue

All RSML series furnaces have a separation plate between the extension pipe and blower partition. **SEPARATION PLATE MUST BE REMOVED WHEN USED AS REAR FLUE.** The plate can be removed by removing the lower right screw, and loosening the others. Once plate is removed, reinsert screw and retighten all 4 screws. See diagram on right.

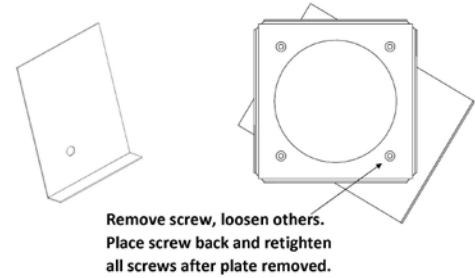

Ventilation and Combustion Air

Appliances shall be installed in a location where the facilities for ventilation permit the satisfactory combustion of oil, proper venting and the maintenance of ambient temperature at safe limits under normal conditions of use. The burner requires a generous amount of clean combustion air to operate safely. The furnace room must be well ventilated to allow sufficient make-up air to support combustion.

Inadequate combustion air may result in erratic operation of the burner, noisy combustion or fuel odors in the air. **NEVER BLOCK THE FURNACE FROM THE SUPPLY OF COMBUSTION AIR.** Remember, your need for outside air will be greatly increased if you have a vented dryer in the basement or other venting fans in the home. Do not install an exhaust fan in the same room as the furnace.

In unconfined spaces in buildings of conventional construction, infiltration is adequate to provide air for ventilation and combustion. If the unconfined space is within a building having insufficient air because of tight construction, the air required for combustion and ventilation shall be obtained from outdoors or from spaces freely communicating with the outdoors. In this situation, permanent openings having a total free opening area of not less than 1 square inch per 5000Btu/Hr of total input of all appliances must be provided.

If the furnace is located in a confined space (A space whose volume is less than 50 cubic feet per 1000Btu/Hr of the combined input ratings of all appliances installed in that space) the confined space shall have two permanent openings, one 6 inches from the top of the space and one 6 inches from the bottom of the space. Each opening shall have a free area opening of not less than 1 square inch per 1000Btu/Hr of total input rating of all appliances in the enclosure freely communicating with interior areas having adequate infiltration with the outside.

If adequate infiltration air is not available the confined space shall be fitted with two openings, one 6 inches from the top of the enclosure and one 6 inches from the bottom of the enclosure. Each opening shall have a free area of at least 1 square inch per 2000Btu/Hr of the total input of the appliances in the enclosure.

In calculating free area, consideration must be given to the blocking effect of louvers, screens or grills protesting the opening. Screens used shall not be less than ¼” mesh and shall be readily accessible for cleaning.

Burner Installation

NOTICE

Remove the oil burner from its shipping carton and inspect thoroughly. Verify that the correct burner combination and nozzle is installed in the burner as shipped.

Read the oil burner manual included in the shipping carton and follow the instructions for preparing and installing the burner. Refer to the tables for the burner specifications for your unit.

On units which can be multi fired, a nozzle change may be required. Follow the oil burner manuals instructions for the proper installation of the nozzle.

Verify that the electrode settings match the manufacturers recommended settings.

The oil burner is to be bolted to the front plate in the proper rotation using the burner mounting flange gasket and the nuts supplied. Refer to the wiring section of this manual for the correct wiring connections to the furnace and to the oil burner manual for fuel piping.

Table 9: Beckett Burner Specifications

Furnace Model	Burner Model	Delavan Nozzle	Pump Press.	Air Band ¹	Air Shutter ¹	Head	Head Position	Tube Length ²	Insertion	Static Plate
RSM/L 500	AFG ³	0.40X60°W	175	0	5	L2	Fixed	9"	4-1/4"	3-3/8
RSM/L 600	AFG ³	0.50X60°W	150	0	7	L2	Fixed	9"	4-1/4"	3-3/8
RSM/L 750	AFG ³	0.60X60°B	150	2	10	L2	Fixed	9"	4-1/4"	3-3/8
RSM/L 850	AFG ³	0.65X60°B	175	0	8	V1	0	9"	5-1/4"	2-3/4
RSM/L 1005	AFG	0.75X60°B	175	0	8	V1	0	9"	5-1/4"	2-3/4
RSM/L 1105	AFG	0.85X60°B	175	0	7	V1	1	9"	5-1/4"	2-3/4

Notes: 1. Approximate air settings, see start up procedures for final adjustments.

2. Stainless Air Tube. 3. Low Firing Rate Baffle installed. Shipped loose for RSM 855 Must be Installed

Table: 10 Riello Burner Specifications

Furnace Model	Burner Model	Delavan Nozzle	Pump Press.	Air Setting ¹	Turbulator Setting	Tube Length	Insertion
RSM/L 500	40F3	0.40X80°A	165	1.50	0	8"	4-1/4"
RSM/L 600	40F3	0.50X80°A	165	2.75	0	8"	4-1/4"
RSM/L 750	40F3	0.60X80°A	165	3.25	1.0	8"	4-1/4"
RSM/L 850	40F5	0.65X60°W	175	2.0	0	8"	5-1/4"
RSM/L 1005	40F5	0.75X60°W	175	2.5	1	8"	5-1/4"
RSM/L 1105	40F5	0.85X60°W	175	2.75	1	8"	5-1/4"

Notes: 1. Approximate air settings see start up procedures for final adjustments

Table 11: Carlin Burner Specifications

Furnace Model	Burner Model	Delavan Nozzle	Pump Press.	Air Setting ¹	Head Setting	Tube Length	Insertion
RSM/L 500	N/A	N/A	N/A	N/A	N/A	N/A	N/A
RSM/L 600	EZ-LF	0.50X60°A	165	25%	1	9"	4-1/4"
RSM/L 750	EZ-LF	0.60X60°A	165	45%	1	9"	4-1/4"
RSM/L 850	EZ-LF	0.65X60°A	175	0.65	0.60/0.65	9"	5-1/4"
RSM/L 1005	EZ-LF	0.75X60°A	175	0.75	0.75	9"	5-1/4"
RSM/L 1105	EZ-LF	0.85X60°A	175	0.85	0.85/1.00	9"	5-1/4"

Notes: 1. Approximate air settings see start up procedures for final adjustments

Wiring

WARNING Electric shock hazard can cause severe personal injury or death if power source, including service switch for the furnace, is not disconnected before installing or servicing the unit.

All wiring must conform to the National Electrical Code NFPA 70, latest edition and any additional state or local codes.

All wiring must be N.E.C. Class 1. If original wiring as supplied with the furnace must be replaced, replace with type 105°C wire or equivalent only. Use copper conductors only.

Power

Supply wire for the furnace must be sized for the load requirement as listed on the furnace rating plate.

Connect 120 VAC 60HZ single phase separate electrical line from the main house panel to the power leads in the junction box attached to the furnace as indicated in the electrical wiring diagrams. Provide a fused disconnect in the power line following all code requirements. Connect the burner to the factory wired burner harness as shown in the electrical diagrams.

Provide electrical ground at the furnace as required by codes.

Emergency Power Switches

Oil burner emergency switches are to be installed as required by code. The homeowner should be made aware of the location and proper operation of all emergency shut off switches

Thermostat and Wiring Connections

Thermostats are to be non power stealing with dry contacts only.

All thermostat and outdoor compressor signal connections are to be made on the Hydrolevel OFC-5000 terminal strip.

For ease of installation remove the bolt in the bottom left corner of the control mounting plate and hinge the mounting plate upward on the top two bolts.

When installing a heat pump the “O” terminal is for reversing valve energized for air conditioning operation.

Oil burner operation is controlled by the Hydrolevel OFC-5000. The “T-T” connection on the oil burner if provided should be jumped. **No thermostat connections should be made to the oil burner primary control.**

When installing a thermostat incorporating a humidistat it must be configured to break on high humidity. The humidistat will cause the blower to run at 90% of the desired air flow for improved dehumidification. **A jumper wire must be installed between “R” and “DH” if no humidistat is present to dehumidify.**

It is recommended to use a thermostat with an outdoor sensor to make the fuel change over from heat pump to oil instead of a fossil fuel kit.

Conventional System (1) Stage Heat (1) Cool PSC Motor

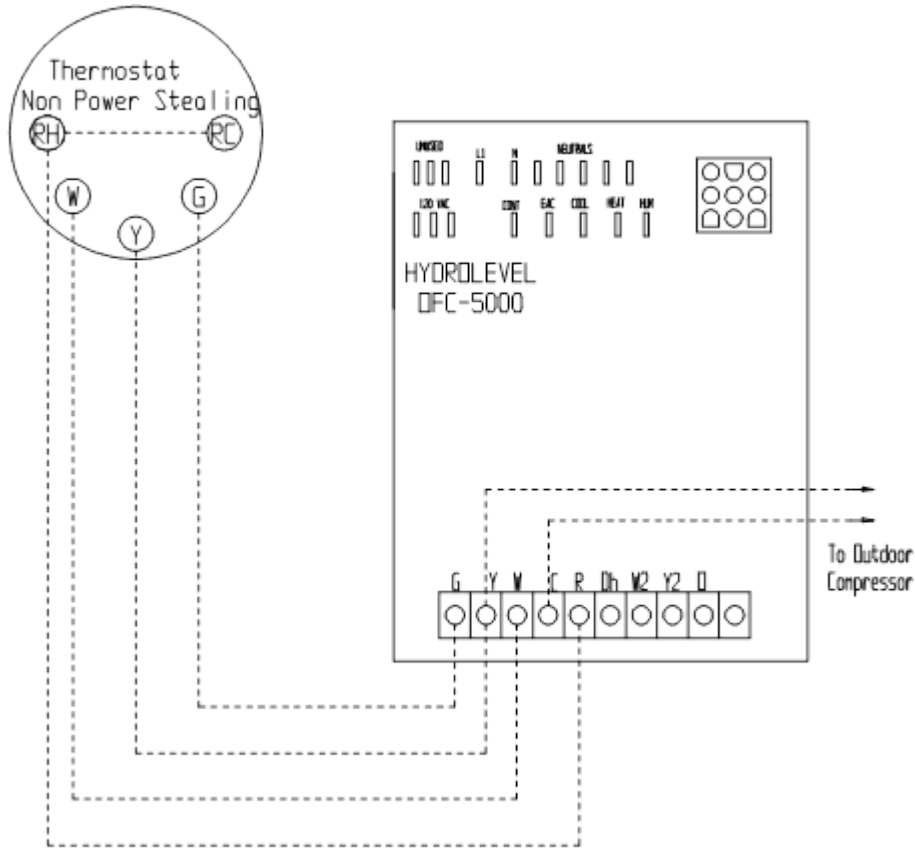

Conventional System (1) Stage Heat (1) Cool ECM Motor

Humidistat breaks on high humidity. Jumper “R”-“DH” if not used.

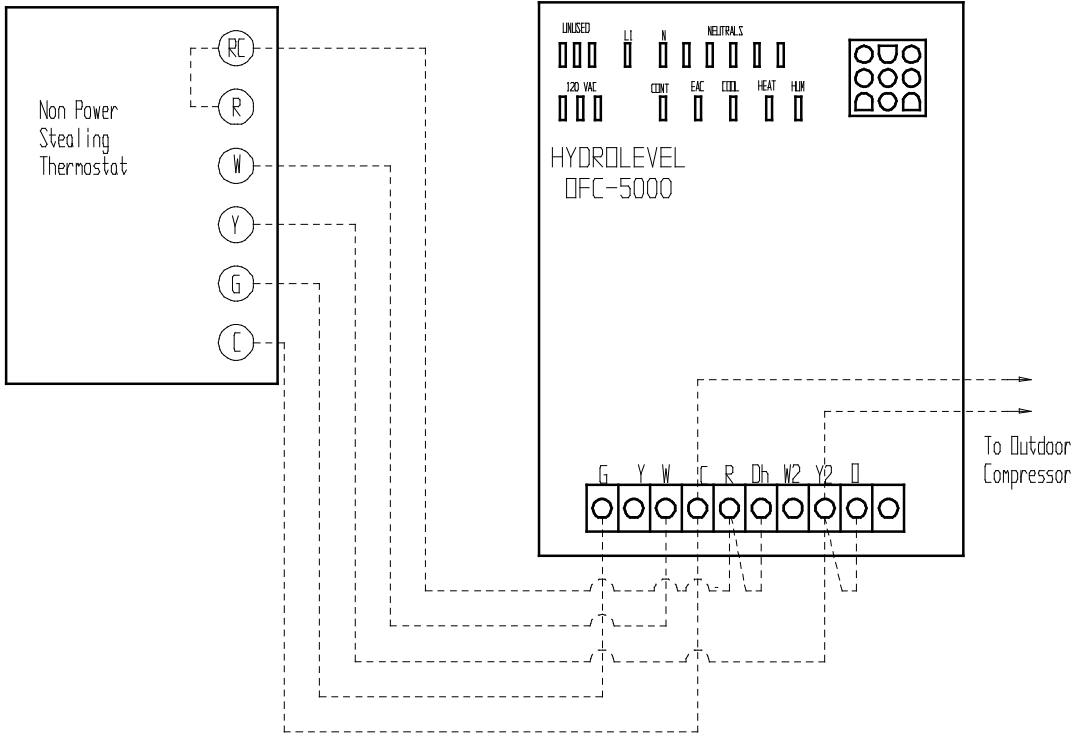

Conventional System (1) Stage Heat (2) Cool ECM Motor

Humidistat breaks on high humidity. Jumper “R”-“DH” if not used.

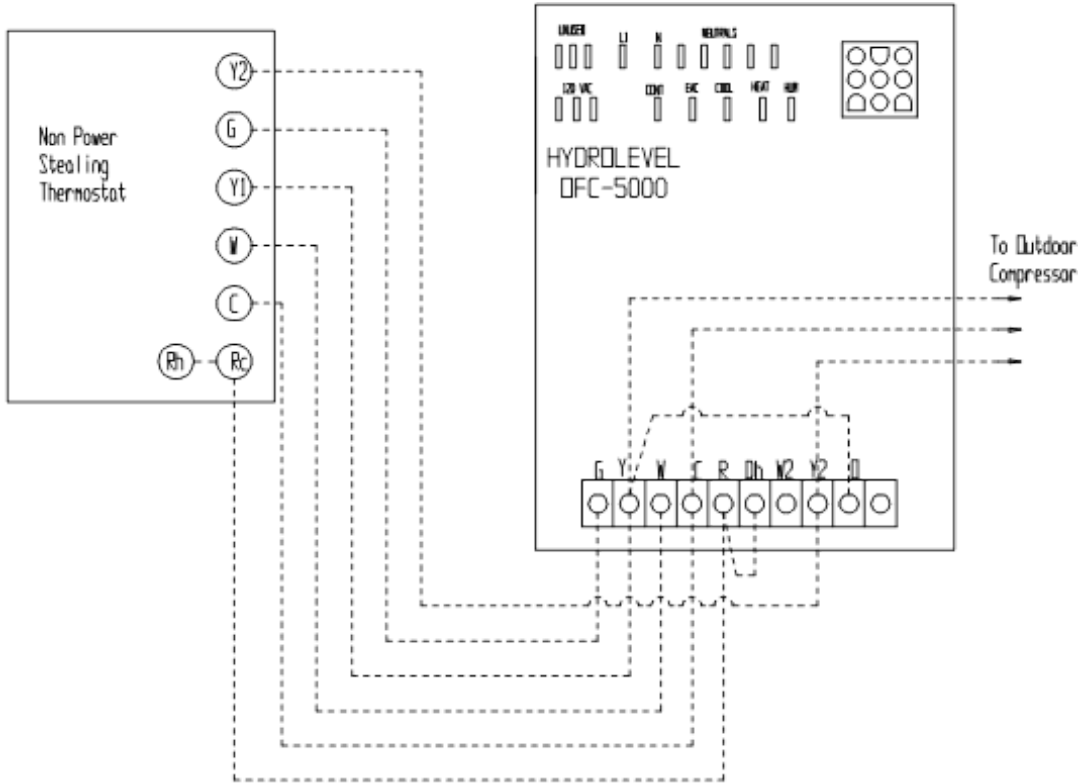

Heat Pump (1) Stage Heat (1) Stage Cool PSC Motor - Furnace Auxiliary Heat

“O” Terminal on Hydrollevel OFC-5000 terminal is to be energized on cooling. If thermostat “O/B” terminal energizes for heating, do not connect to Hydrollevel OFC-5000 “O” terminal. Humidistat breaks on high humidity. Jumper “R”-“DH” if not used.

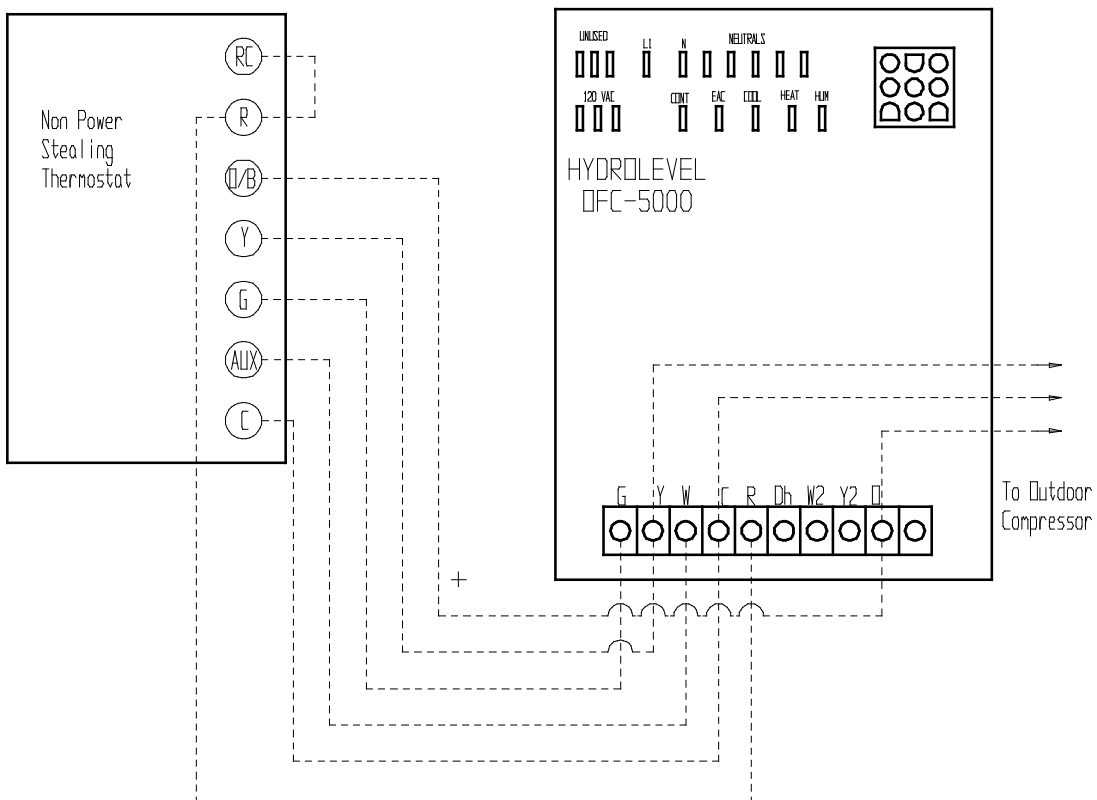

Heat Pump (1) Stage Heat (1) Stage Cool ECM Motor - Furnace Auxiliary Heat

“O” Terminal on Hydrolevel OFC-5000 terminal is to be energized on cooling. If thermostat “O/B” terminal energizes for heating, do not connect to Hydrolevel OFC-5000 “O” terminal. Humidistat breaks on high humidity. Jumper “R”-“DH” if not used.

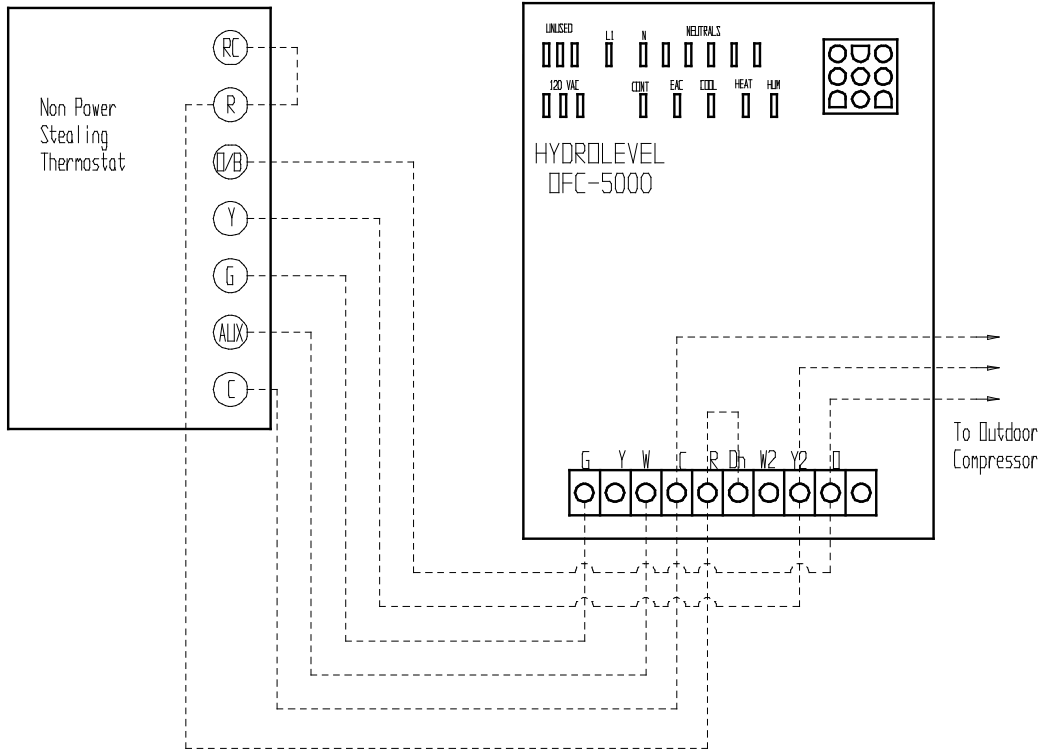

Heat Pump (2) Stage Heat (2) Stage Cool ECM Motor - Furnace Auxiliary Heat

“O” Terminal on Hydrolevel OFC-5000 terminal is to be energized on cooling. If thermostat “O/B” terminal energizes for heating, do not connect to Hydrolevel OFC-5000 “O” terminal. Humidistat breaks on high humidity. Jumper “R”-“DH” if not used.

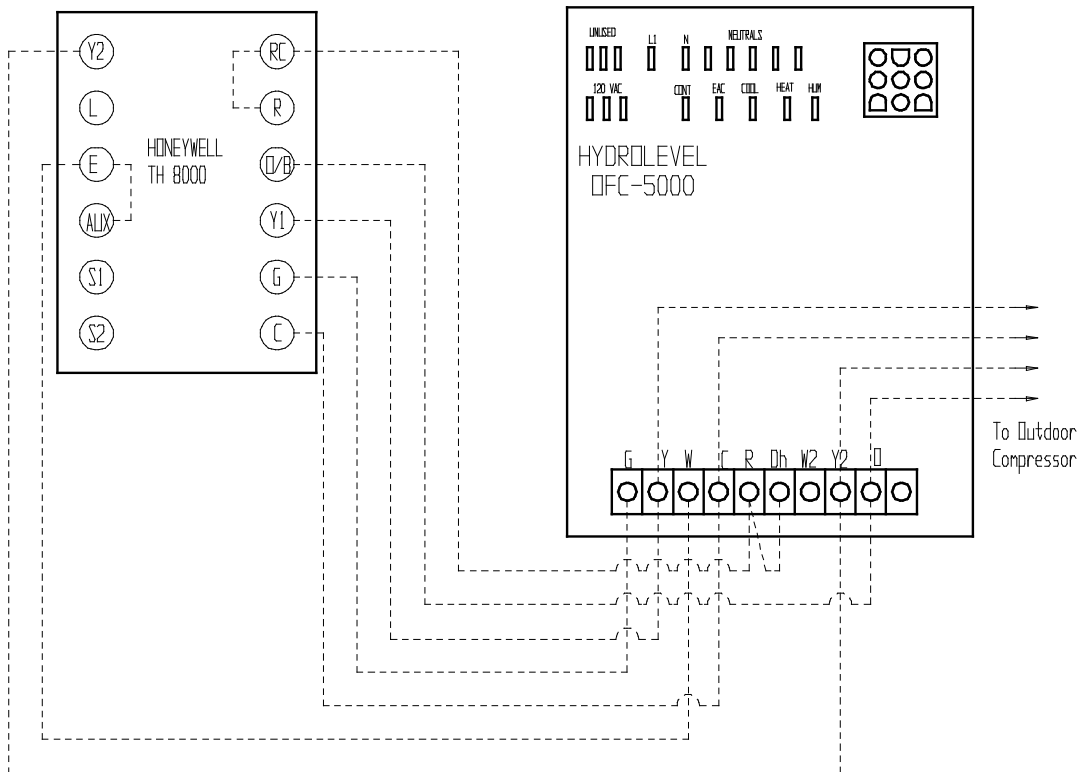

RSM Furnace Wiring 3 Speed PSC Motors

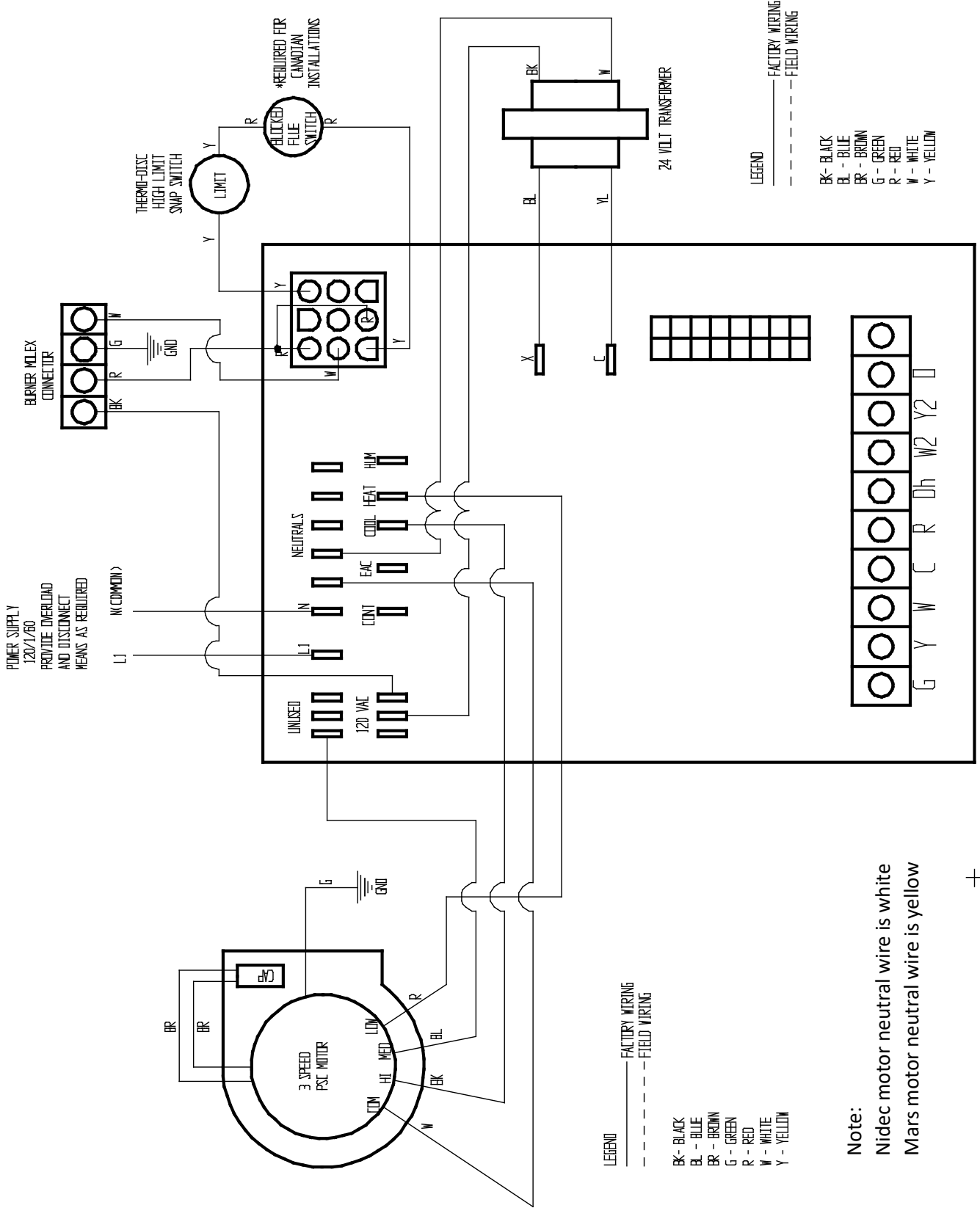

RSM Furnace Wiring 4 Speed PSC Motors

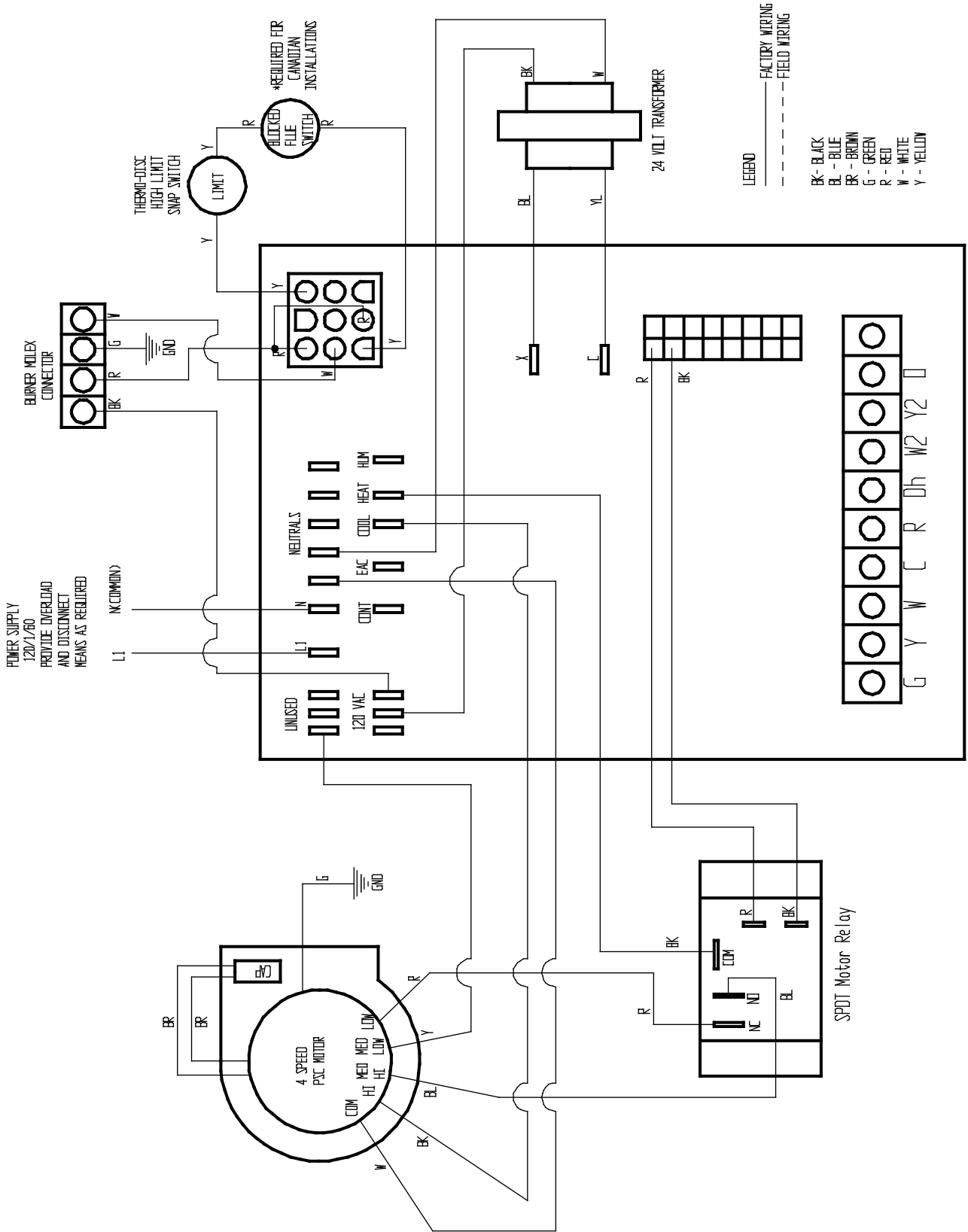

RSML Furnace Wiring 3 Speed PSC Motors

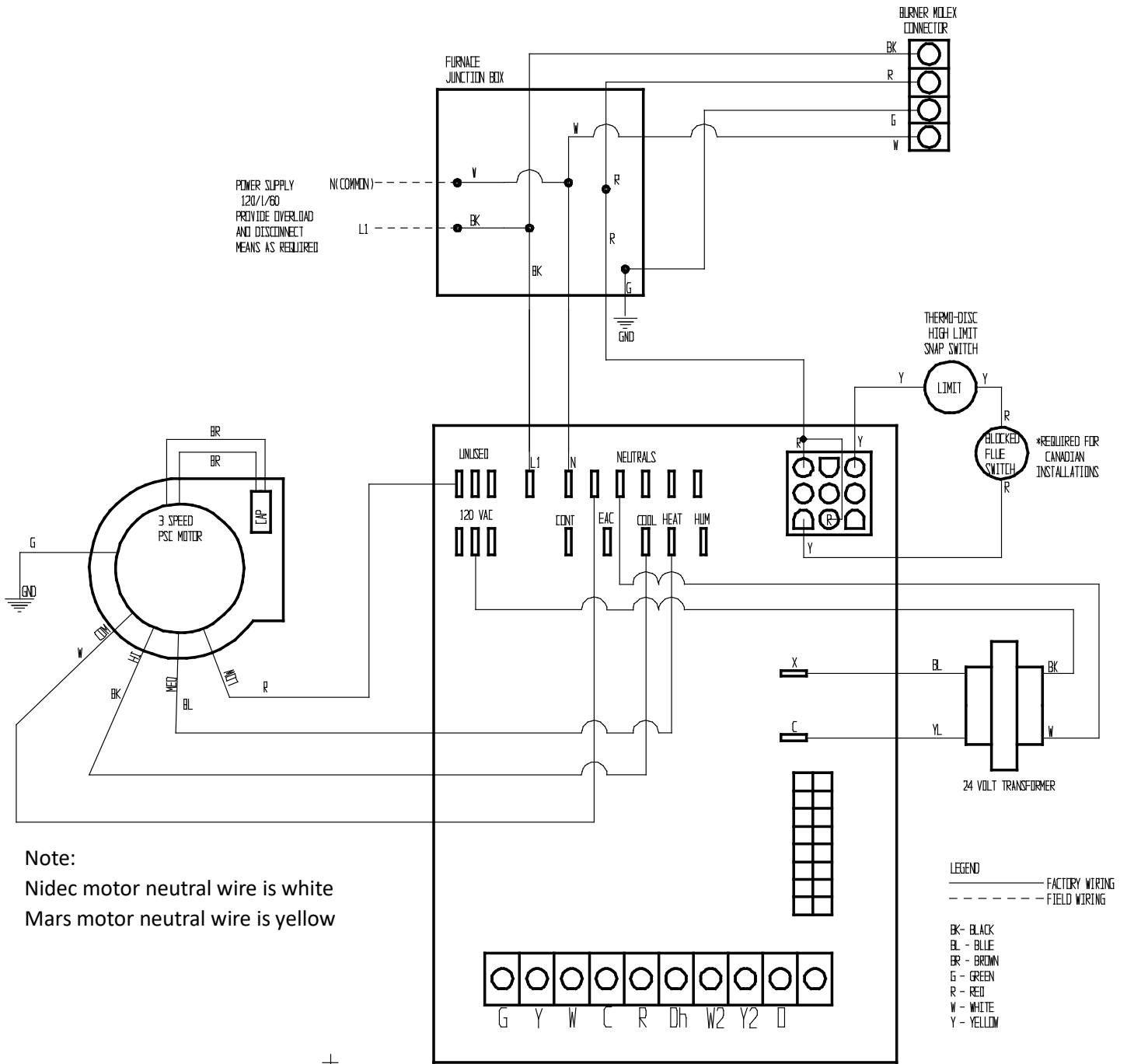

Note:
Nidec motor neutral wire is white
Mars motor neutral wire is yellow

RSML Furnace Wiring 4 Speed PSC Motors

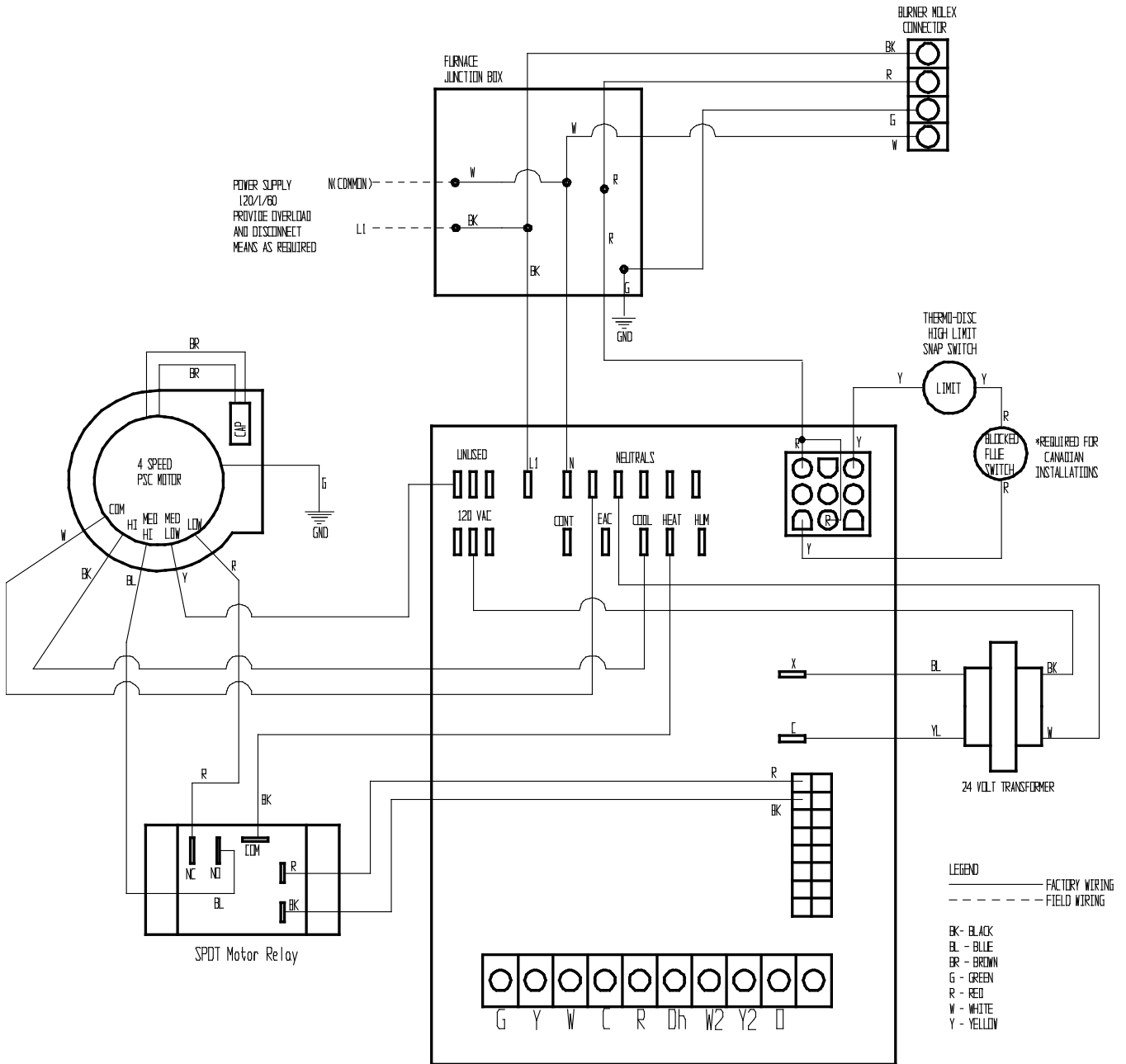

RSM Furnace Wiring Nidec ECM Motors

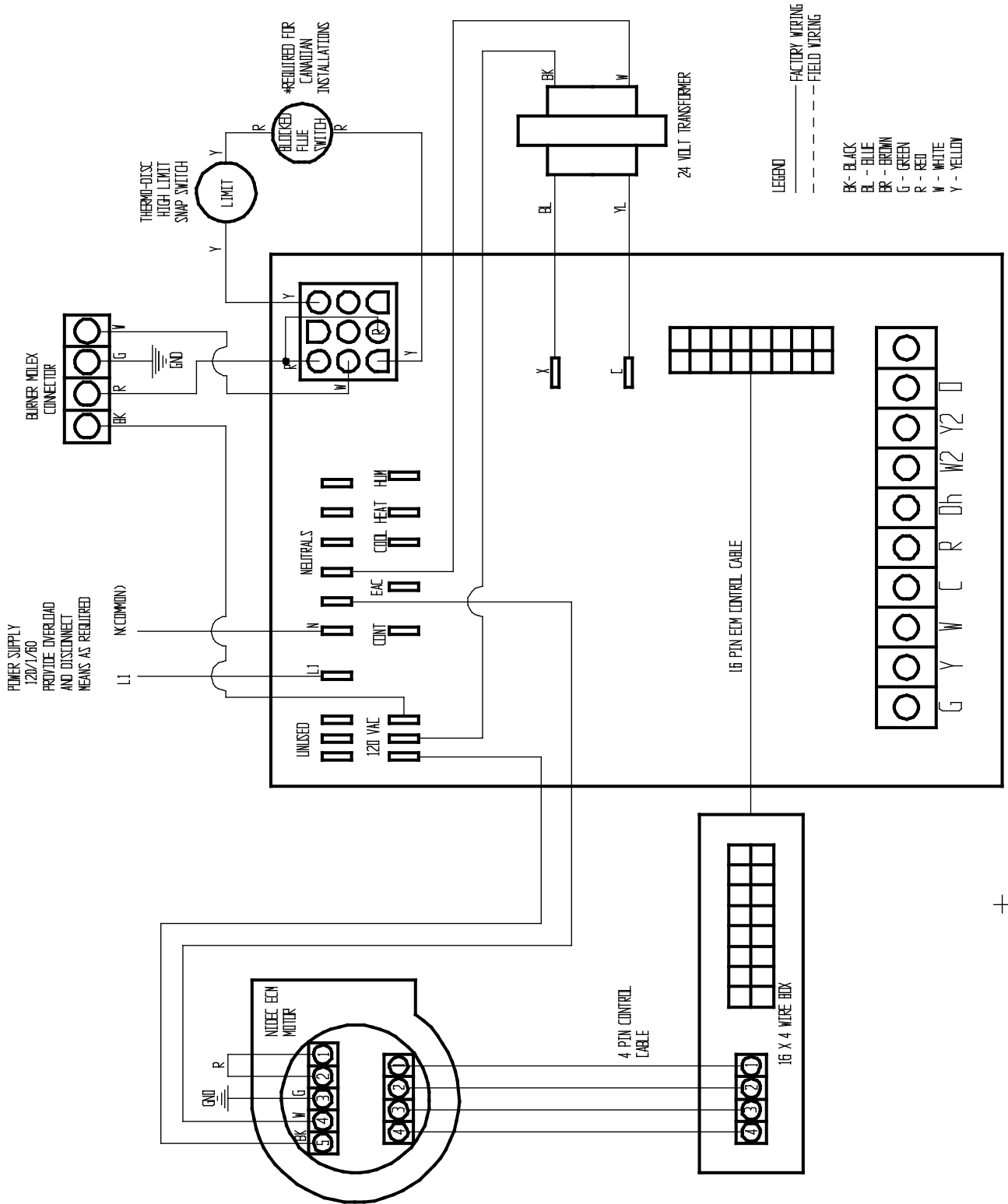

+

RSML Furnace Wiring Nidec ECM Motors

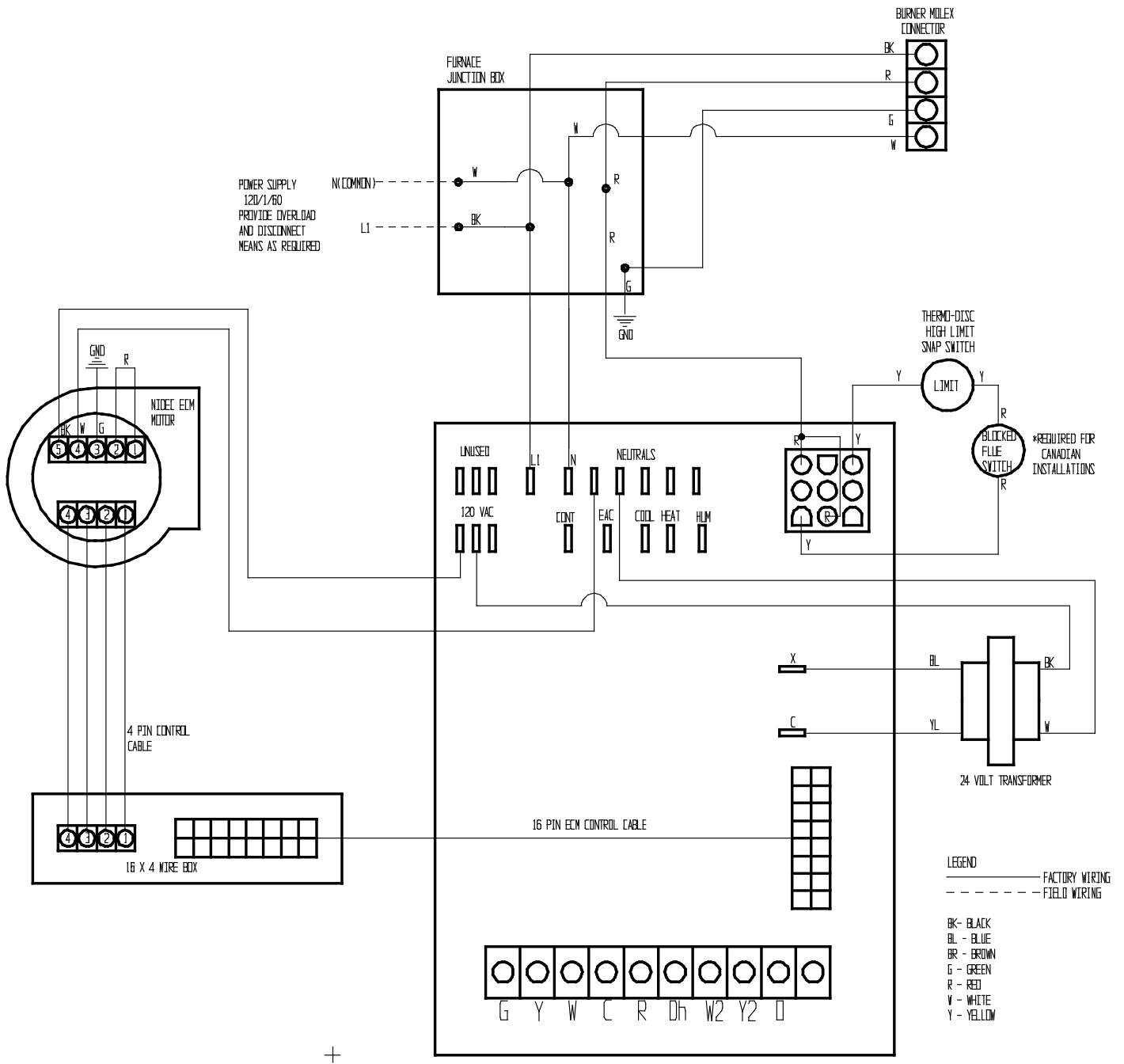

Oil Tank and Piping

WARNING Installation of oil tanks must meet all local codes and ordinances. Refer to NFPA-31 for complete guidelines on oil tank installations internal to the building, outside above and below ground tanks.

Oil tanks located inside the building shall not be in excess of 275 gallons individual capacity and shall not be located within 5 feet horizontally from any source of heat, either internal or external to the appliance being served or in a manner that the temperature of the oil in the tanks exceeds 25°F above room temperature.

Connect burner to oil supply using the correct size heavy wall copper tubing, wrought iron, steel or brass fittings in accordance with the literature attached to the pump. All lines must have a shut off valve to minimize the discharge of fuel when removable components such as filter elements and cleanout plugs are removed for routine service or cleaning operations.

Use an oil filters with the proper capacity for all installations. Install the filter inside the building between the tank shutoff valve and the burner. To further protect the fuel system and reduce orifice plugging a dual filtration system can be installed. This would typically consist of a 50 micron primary filter, located near the fuel tank and a secondary filter rated for at least 10 microns located near the burner. The filter cartridge should be replaced at least once a year. The filter body should be thoroughly cleaned before installing a new cartridge

Use flare fittings only when assembling oil lines. Avoid use of fittings in inaccessible locations. Avoid running tubing against any type of heating unit and across ceiling or floor joists. Piping shall be supported and protected from physical damage and where necessary, protected against corrosion as per code. Piping systems shall be maintained liquid tight. A piping system that has leaks constitutes a hazard which must be repaired in an approved manner. All oil feed lines to burners must be air tight. The slightest air leak, caused by loose fittings, bad gaskets or any other reason, can cause a foaming oil stream which will cause any of the following conditions:

- a) Intermittent firing, causing safety shutdown.
- b) Poor starts.
- c) Smokey starts.
- d) Continual sooting of furnace and burner parts including the cad cell.
- e) Reduced firing rate, inefficient operation and erratic fire pattern.
- f) A dangerous combustion condition, allowing the combustion chamber to fill with a lean mixture (too much air in the oil stream) which could cause a delay in ignition of the fuel mixture until the danger point has been reached.

This fuel unit when connected with a single pipe system is satisfactory only where the oil supply is on the same level or above the burner, permitting gravity flow of oil. When it is necessary to lift oil to the burner, a return line must be connected between the fuel unit and the tank. This requires the insertion of the "bypass" plug in the oil pump. The bypass plug and pump instructions are attached to the pump. Installation of a check valve in the suction line of a two-pipe system is advisable under all circumstances. Be sure the check valve fittings are air tight. If lift exceeds 10 ft. a two-stage pump must be installed with a two-pipe system.

If any part of the fuel oil tank is above the burner, an anti-siphon device must be used to prevent the flow of oil in case of an oil line breakage.

Suction vacuum must be held to acceptable limits. **THE VACUUM TEST IS WORTH THE TIME REQUIRED TO MAKE IT.** This problem becomes proportionately larger with underground tanks. Connect vacuum gauge to oil pump. Suction vacuum must not exceed 10 inches of mercury for single stage pumps and 15 inches for two stage pumps. It is preferable to stay below these limitations. When the suction line is tight and properly installed the pump will hold its vacuum for a minimum of 60 minutes after shutdown.

Outside Buried Tank Lift System

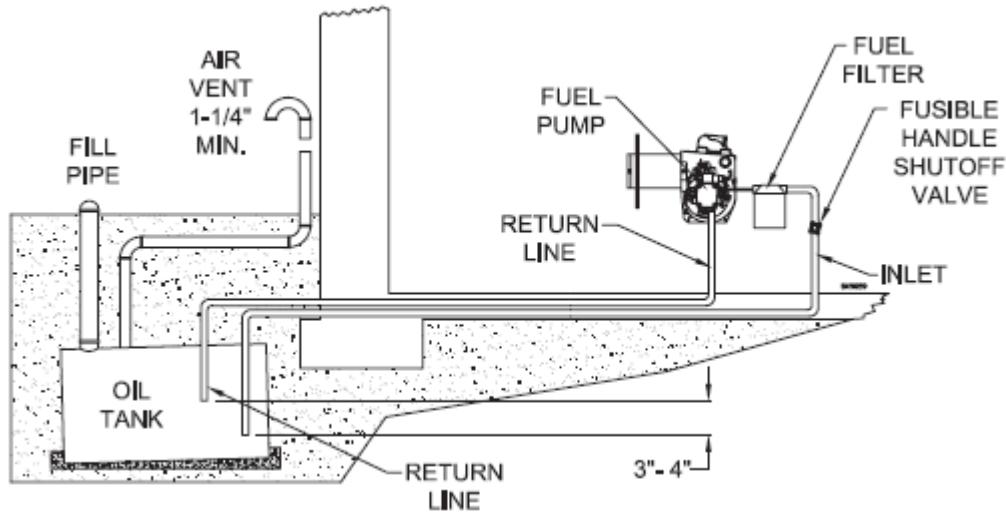

Inside Tank Gravity Feed System

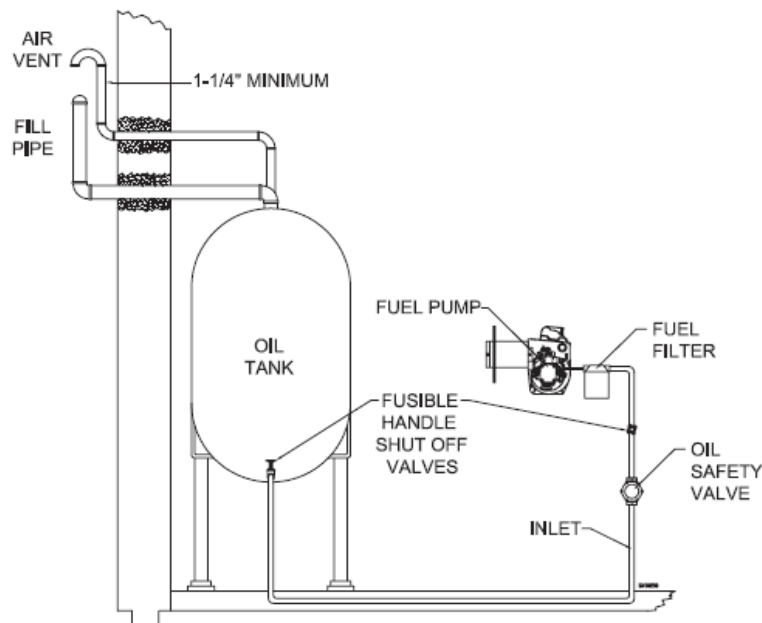

Start-Up

WARNING Use number No. 1 or No. 2 fuel oil only.

Do not attempt to start the burner if excess oil has accumulated.

Do not use gasoline, crankcase draining or any oil containing gasoline.

This equipment must be adjusted and started only by a qualified service agency – an individual or agency, licensed and experienced with all codes and ordinances, and who is responsible for the installation and adjustment of the equipment.

1. Check that all safety devices are in place.
2. Check that thermostats are correctly connected and set.
3. Check that the inside of the furnace is free of any fuel residue or foreign materials and that the refractory chamber has not been damaged.
4. Check oil burner nozzle to ensure that the right size and type is installed and tight in the adapter. See preliminary settings for proper nozzle size and type.
5. Check electrode settings, as they may have been jarred out of position during transportation. See oil burner instructions for nozzle and electrode setting
6. Check air setting to ensure that it matches the preliminary air settings as found in Table 9, Table 10, or Table 11.
7. Check that the Burner mounting bolts are tight.
8. Lubricate burner motor and circulator motor if required.
9. Open all oil lines valves.
10. Set room thermostat to call for heat.
11. Turn service switch on. Burner should start. On one pipe fuel system only, you may have to bleed the oil system. To bleed attach a clear plastic tube to the oil pump bleed port and allow oil to run until all the air is out of the oil suction line feeding the oil burner. If air is still evident in the bleed line you must check the oil lines, all fittings, filters and any other connections for tightness. See burner and fuel pump manufacturers recommendations for proper bleeding of the fuel system.
CAUTION: DO NOT RUN THE PUMP DRY FOR MORE THAN FIVE MINUTES. AS IRREPAIRABLE DAMAGE MAY RESULT.
12. Turn “OFF” burner and install pressure gauge and vacuum gauge into the proper ports on the pump. See the burner manufacturer’s manual for location of ports.
13. Start burner again and check oil pressure. Adjust if necessary. See oil burner manufacturers’ instructions for pump adjustment.

Start-up Equipment

THE FOLLOWING PROPER COMBUSTION INSTRUMENTS ARE REQUIRED TO DETERMINE PROPER AIR ADJUSTMENTS AND DRAFT WHEN SETTING UP OR SERVICING THE OIL BURNER. DO NOT ATTEMPT TO START UP OR SERVICE THE FURNACE WITHOUT THE PROPER COMBUSTION INSTRUMENTS.

1. Carbon-dioxide (CO₂) or Oxygen (O₂) Analyzer
2. Draft gauge. Scale should read from +.10" WC to -.25" WC
3. Oil Pressure Gauge 0-200 PSI
4. Stack Thermometer
5. Plenum Thermometer
6. Smoke Test Gun
7. Vacuum Gauge 0-30 in. of Hg
8. Volt meter
9. Amp meter

Burner Adjustments

Allow the burner to operate for at least 10 minutes before making the following adjustments. The factory burner settings may not be suitable for specific job conditions.

Do not attempt to make any adjustments or start the furnace without the proper equipment.

1. A 5/16" diameter hole will be required in the flue pipe between the furnace and the barometric damper as close to the furnace as possible.
2. Set the draft regulator (barometric damper) using a draft gauge to obtain a negative draft of -.03" to -.04" WC in the flue.
3. Pump pressure – Install a pump pressure gauge in the oil pump following the oil burner manufacturers' recommendations. Adjust to obtain required pressure as necessary.
4. Combustion Set-up – The air settings shown in Table 8 thru Table 10 are approximate. The burner must be adjusted during actual field installed conditions. Failure to do so will result in poor performance and nuisance service calls. After proper draft and oil pressure have been established:
 - a. Begin to close the air band to create a slight trace of smoke as noted on the Bacharach or equivalent smoke tester scale.
 - b. Take a flue gas sample and note the CO₂ reading. It will be about 12% to 14%
 - c. Open the air band to reduce the CO₂ approximately 1%. The desired CO₂ setting for all units should be 11% to 13%
 - d. Check for "0" smoke. Head settings and/or air band may be altered to obtain the above results. Lock the air band and head setting screws in place.

The above procedure will give a built-in margin to ensure clean operation throughout the heating season. Should draft conditions vary, lint accumulate in the fan, heavier oil delivered, or other adverse conditions be encountered you will have a reasonable margin of built-in protection before smoke generation begins.

5. Flue Gas Temperature - The flue gas temperature will vary to some degree depending on BTU inputs, duct design and the air flow across the heat exchanger. The suggested minimum NET stack temperature is 350°F, and the maximum stack temperature is 550°F. The lower the stack temperature, the higher the efficiency; however, stack temperatures under 350°F may cause condensation which in turn may cause metal corrosion.
6. Temperature Rise - Supply air temperature minus return air temperature. The temperature rise across the furnace (operating at steady state conditions) should be approximately 60°F. A higher temperature rise would slightly lower the efficiency. The supply air temperature should be measured in the supply air trunk-line approximately 12 inches down stream of the plenum.
Do not exceed the maximum temperature rise as listed on the furnace nameplate.
7. Check operation of the cad cell relay by removing cad cell wire from external terminal of primary safety control to ensure that it goes off on safety.
8. Check blower motor amperage under both heating and air conditioning loads and ensure that the amperage is less than the full load nameplate amperage of the blower motor.

Operating and Maintenance Instructions

WARNING

The furnace must be installed, adjusted and maintained only by a qualified service agency annually. Have your unit inspected, cleaned and adjusted at least once a year to assure proper operation. In the event of extended shut down of the furnace have a qualified service person inspect before restarting the furnace. Do not tamper with the unit or controls. Incorrect operation of the unit could result in severe personal injury and property damage.

Never attempt to use gasoline in the furnace.

Never store gasoline or other combustible materials near the burner or appliance. The area around the furnace should be kept clear of all combustible materials.

Never attempt to burn garbage or refuse in the furnace.

Never attempt to light the furnace by throwing burning material into the furnace.

Never attempt to use crankcase or waste oil or materials other than the approved fuel oils in this furnace.

Never restrict the air inlet openings to the burner.

Do not attempt to start the furnace when excess oil has accumulated in the chamber or the furnace is full of vapors.

Cleaning

WARNING

Cleaning of the heat exchanger must be done yearly by a qualified service technician.

It is important to inspect and clean the heat exchanger once annually or as necessary to remove any build up of soot. A layer of soot on the inside surface of the heat exchanger will result in reduced efficiency.

1. Turn off all power to the furnace.
2. Remove clean out covers and the flue pipe.
3. Remove the burner.
4. With access to the inside of the heat exchanger through the cleanout covers remove the flue tube baffles and use a soft flue brush to remove any soot build up. Access to the chamber area is through the burner opening.
5. Vacuum any loose debris.
6. Inspect heat exchanger and combustion chamber.
7. Replace the baffles, Cleanout covers and burner. Replace any of the gaskets which would not be able to provide an adequate seal.
8. Clean and readjust the oil burner as required.

Oil Burner

NOTICE

Refer to the oil burner instruction manual provided with the burner for proper maintenance and service.

Burner Components: If replacement of burner parts is necessary, always use parts recommended by the manufacturer. Specify part number and description when ordering.

Electrode settings are important for reliable ignition of the oil. Check to be sure the settings are in accordance with the instructions provided in the burner manual.

Nozzles: ANY NOZZLE REPLACEMENT SHOULD BE OF THE EXACT TYPE AS THE ORIGINAL SUPPLIED BY THE MANUFACTURER. Use extreme care in handling nozzles to avoid scratches or dirt that could cause leaks or affect the oil spray pattern.

Perform the combustion checks as per the burner manual and the furnace manual.

Blower Removal

1. Shut off Oil and power to the furnace.
2. Disconnect Molex plug at burner.
3. Remove the screws which attach the blower door to the jacket side panels.
4. Open the blower compartment.
5. Disconnect the spade connectors attached to the yellow wires which go from the 9 pin Molex connector to the snap disc high limit.
6. Remove the two screws securing the blower to the blower partition (RSM models) or base pan (RSML models).
7. Slide the blower towards you to remove.

Clean inspect blower wheel annually. Lubricate blower motor as per the motor manufacturer's recommendations.

Vent System

Clean and inspect the flue pipe draft regulator and chimney annually as outlined in this manual.

Fuel Oil System

Check oil tank and piping for leaks annually, replacing the oil filter to avoid contamination of the fuel unit and nozzle.

Filters

Air filters should be inspected and replaced if required monthly. The filters supplied with the furnace are disposable and need to be replaced with the exact type and size as supplied. Dirty or clogged air filters will impair the furnace performance and may cause the furnace to shut down or overheat.

Do not add additional filters unless the duct system is sized to allow for the additional pressure drop.

When the furnace is shut down for an extended period of time a qualified service agency should inspect the furnace and change filters before restarting.

RSM

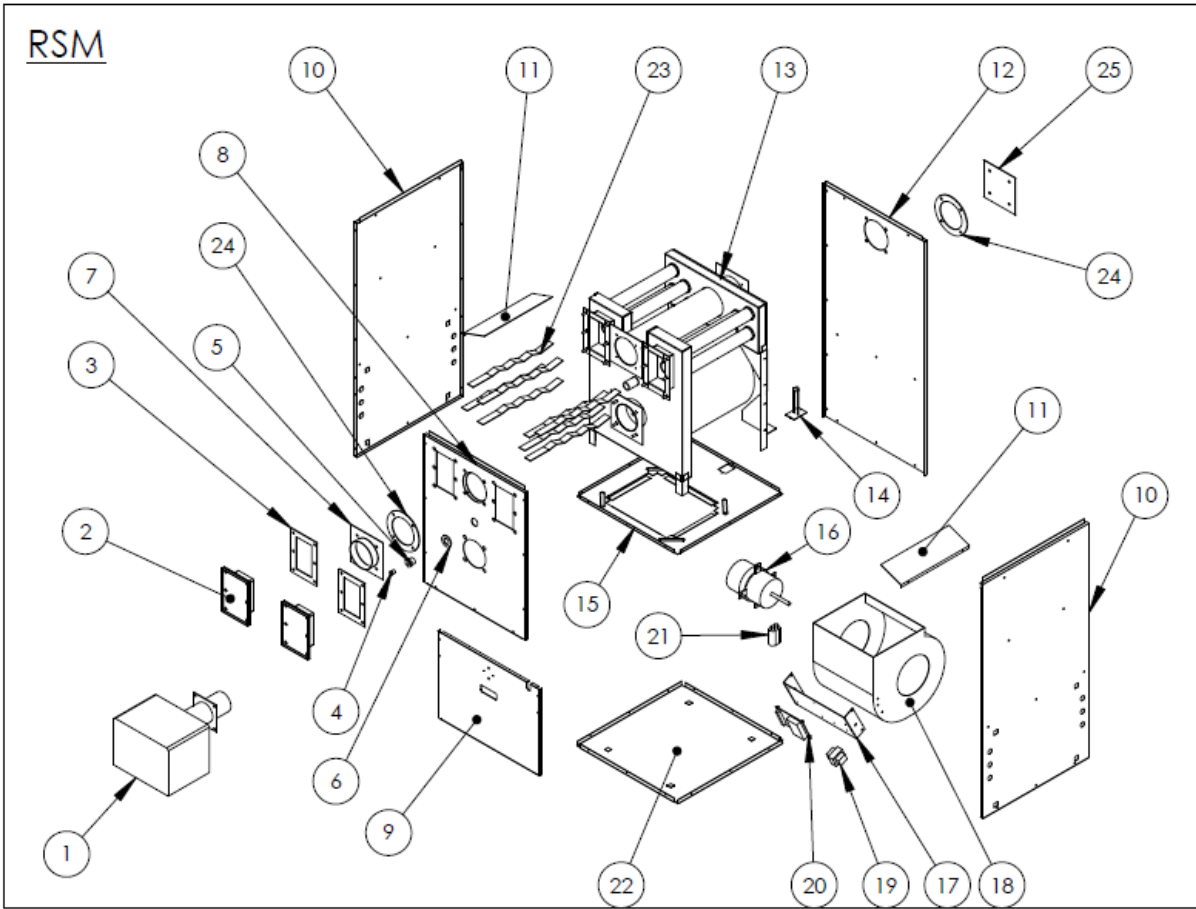

Item No.	Qty	Description	RSM 600 Part No.	RSM 1005 Part No.
1	1	BURNER - BECKETT	540609B	540611B
1	1	BURNER - RIELLO	540860	540862
1	1	BURNER - CARLIN	540820	540830
2	2	CLEAN OUT COVER COMPLETE	17150	17150
3	2	CLEANOUT COVER GASKET	489017	489017
4	1	BRASS PLUG 1/4" NPT	712350	712350
5	1	3/4" X 1/4" BUSHING	310410	310410
6	1	1" WASHER	310094	310094
7	1	FLUE COLLAR	17340	17340
8	1	JACKET FRONT PANEL	17005	17505
9	1	BLOWER DOOR	17030	17530
10	2	JACKET SIDE PANEL	17020	17520
11	2	SIDE AIR BAFFLE	17185	17685
12	1	JACKET REAR PANEL	17015	17515
13	1	HEAT EXCHANGER	17255	17755
14	1	HIGH LIMIT	552315	552316
15	1	BLOWER PARTITION	17040	17540
16	1	MOTOR - PSC NIDEC	712495	712496
16	1	MOTOR - PSC MARS	712505	N/A
16	1	MOTOR - ECM NIDEC	712497	712499
16	1	ECM POWER CABLE- 31"	15050	15050
16	1	ECM 16 X 4 WIRE BOX	712498	712498
16	1	ECM 16 PIN CONTROL CABLE -27"	15052	15052
16	1	ECM 4 PIN CONTROL CABLE -36"	15040	15040
17	1	CONTROL MOUNTING BRACKET	17246	17746
18	1	BLOWER	710401	710400
19	1	TRANSFORMER 40VA	552251	552251
20	1	FAN TIMER BOARD HYDROLEVEL OFC-5000	552335K	552335K
21	1	CAPACITOR 15MFD PSC MOTOR	712430	712430
22	1	BASE PAN	17050	17550
23	8	TUBE BAFFLE	17220	17700
24	2	FLUE GASKET	489019	489019
25	1	FLUE COVER	17335F	17335F

RSML

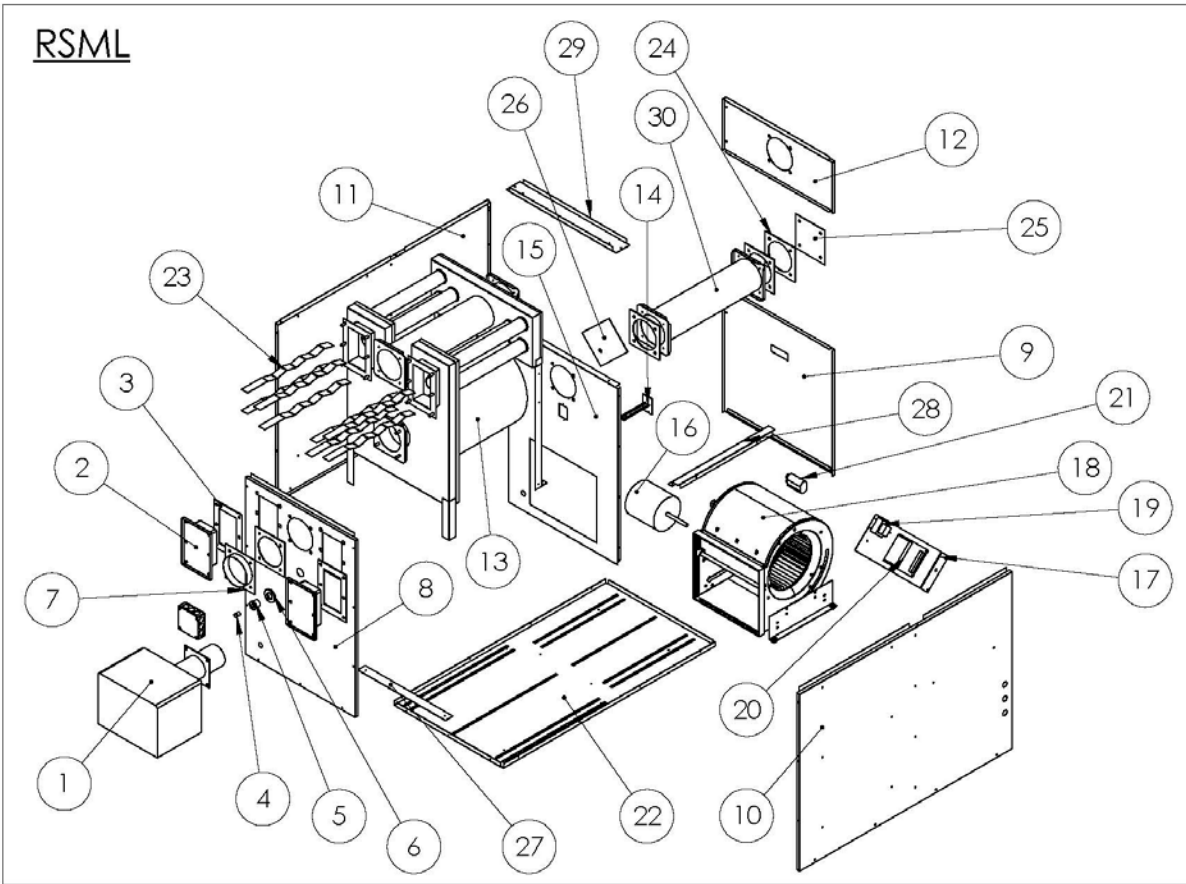

Item No.	Qty	Description	RSML 600 Part No.	RSML 1005 Part No.
1	1	BURNER - BECKETT	540609B	540611B
1	1	BURNER - RIELLO	540860	540862
1	1	BURNER - CARLIN	540820	540830
2	2	CLEAN OUT COVER COMPLETE	17150	17150
3	2	CLEANOUT COVER GASKET	489017	489017
4	1	BRASS PLUG 1/4" NPT	712350	712350
5	1	3/4" X 1/4" BUSHING	310410	310410
6	1	1" WASHER	310094	310094
7	1	FLUE COLLAR	17340	17340
8	1	JACKET FRONT PANEL	16900	17555
9	1	BLOWER DOOR	16915	16915
10	2	JACKET RIGHT SIDE PANEL	16910	17565
11	2	JACKET LEFT SIDE PANEL	16905	17560
12	1	JACKET REAR PANEL	16920	17570
13	1	HEAT EXCHANGER	17390	17756
14	1	HIGH LIMIT	552315	552315
15	1	BLOWER PARTITION	16935	17580
16	1	MOTOR - PSC NIDEC	712495	712496
16	1	MOTOR - PSC MARS	712505	712505
16	1	MOTOR - ECM NIDEC	712497	712499
16	1	ECM POWER CABLE- 31"	15050	15050
16	1	ECM 16 X 4 WIRE BOX	712498	712498
16	1	ECM 16 PIN CONTROL CABLE -27"	15052	15052
16	1	ECM 4 PIN CONTROL CABLE -36"	15040	15040
17	1	CONTROL MOUNTING BRACKET	17246	17746
18	1	BLOWER	710401	710400
19	1	TRANSFORMER 40VA	552251	552251
20	1	FAN TIMER BOARD HYDROLEVEL OFC-5000	552335K	552335K
21	1	CAPACITOR 15MFD PSC MOTOR	712430	712430
22	1	BASE PAN	16930	17575
23	8	TUBE BAFFLE	17220	17700
24	5	FLUE GASKET	489019	489019
25	1	FLUE COVER	17335F	17335F
26	1	SEPARATION PLATE	17355	17355
27	1	FRONT BAFFLE	17360	17360
28	2	FILTER BRACKET	17365	17365
29	1	JACKET TOP CHANNEL	16925	16925
30	1	EXTENSION PIPE	17317W	17317W

Troubleshooting Guide Oil Burner

WARNING This equipment must be serviced, adjusted and started only by a qualified service agency – an individual or agency, licensed and experienced with all codes and ordinances, and is responsible for the installation and adjustment of the equipment.

Burner Goes Off on Safety

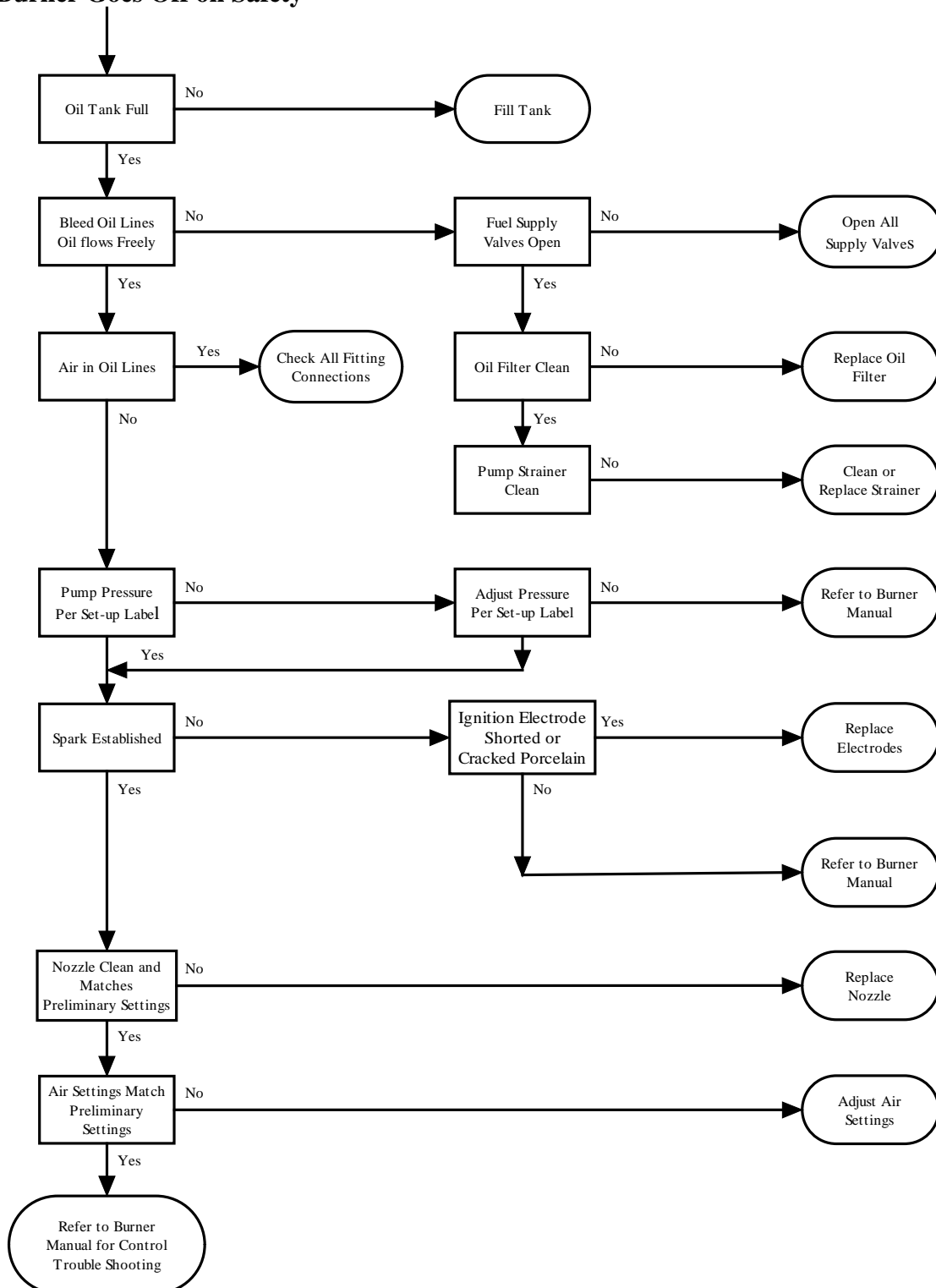

Nidec ECM Troubleshooting

General Troubleshooting

1. Check unit for power.
2. Disconnect or turn off power to the furnace, air handler, or system being serviced and wait 2 minutes. This allows the capacitors in the control unit to fully discharge.
3. Check control unit connectors. Inspect for shorts, detached wiring and or loose connections.
4. Check power cord and communication cable connections. Make sure both are securely connected to control unit connectors.
5. Check blower motor to ensure that spins freely manually without effort. If binding occurs check that blower wheel is not binding in the housing.

Electrical Checkout Motor

1. Disconnect or turn off power to the furnace, air handler, or system being serviced and wait 2 minutes. This allows the capacitors in the control unit to fully discharge.
2. The HVAC system must be wired for 120 VAC power. Verify a jumper wire is installed between positions 1 and 2 of the power cord connector.
3. Disconnect power cord from connector on the control unit. Inspect power cord for bent, damaged or recessed wires and terminals.
4. Restore or turn on power to the furnace.

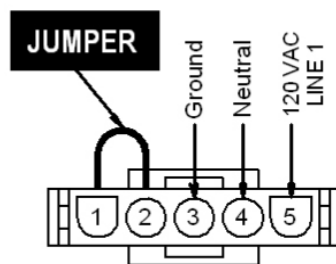

120 VAC System

Electrical Checkout 16 x 4 Wire Box

1. With power applied to the furnace both the “RX” and “TX” lights should be flashing during normal operation.
2. Disconnect or turn off power to the furnace, air handler, or system being serviced and wait 2 minutes. This allows the capacitors in the control unit to fully discharge.
3. Disconnect 4-wire communication cable from connector on control unit. Inspect cable for bent, damaged or recessed wires and terminals
4. Restore or turn on power to the furnace.
5. Check the voltage between positions 1 and 4 of the communication cable connector. If the measured voltage between positions 1 and 4 is NOT 30-35 VDC replace the 16 X 4 wire box. If the measured voltage between positions 1 and 4 is 30-35 VDC, go to control unit verification.

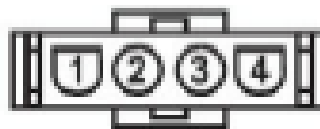

4 Pin Communication Cable

Control Unit Verification

1. Disconnect or turn off power to the furnace, air handler, or system being serviced and wait 2 minutes. This allows the capacitors in the control unit to fully discharge.
2. Remove 3 screws securing the motor and control unit together. Grasp the Control Unit and pull away from motor until both units are separated.

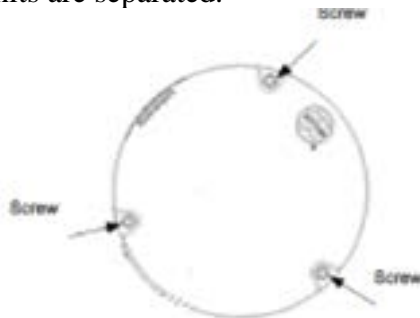

3. Disconnect the 3-wire motor to control harness from the control and remove control unit. Inspect for bent, damaged, or recessed wires and terminals inside of connector. Replace control unit if the three pin connector contains bent, damaged or recessed terminals.

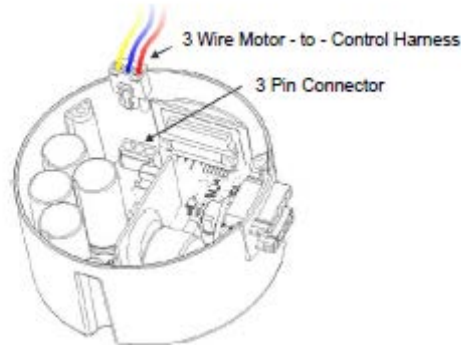

4. Inspect the NTC thermistor inside of control unit for any cracks or breakage. Replace control unit if NTC thermistor is cracked or broken.



5. Inspect capacitors inside of control unit for bulging or swelling. Replace control unit if capacitors are bulging or swollen

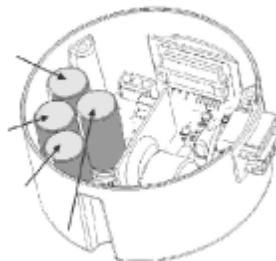

6. Check phase to phase resistance between each of the three phase pins in the harness connector. Resistance levels between any two pins should be greater than 100K. If the multimeter resistance

levels are greater than 100K, the control unit is functioning properly. If the multimeter resistance levels are less than 100K replace the control unit.

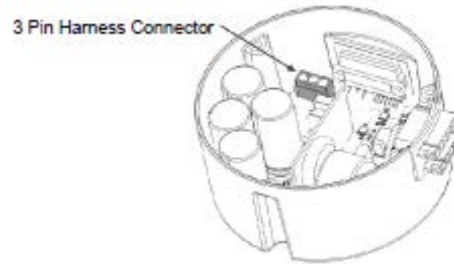

Motor Verification

1. Disconnect or turn off power to the furnace, air handler, or system being serviced and wait 2 minutes. This allows the capacitors in the control unit to fully discharge.
2. Remove control unit if still mounted on motor. See control unit verification steps 2 and 3.
3. Inspect connector on back side of motor for bent, damaged, or recessed wires. Replace motor if connector contains bent, damaged or recessed wires or terminals.

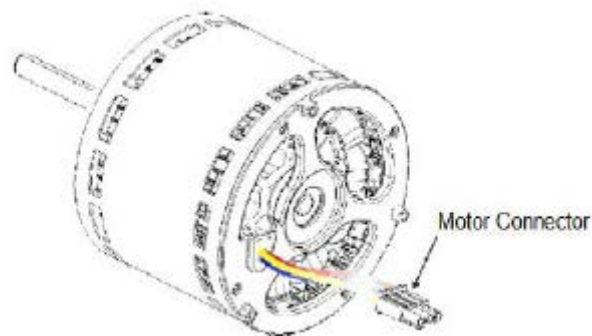

4. Check phase to phase resistance between each of the three phase terminals in the motor connector. Resistance levels between any two contacts should be equal. If resistance is equal motor is functioning properly. Replace motor if the resistance levels are not equal or are open or short circuited.
5. Inspect the magnets through the back side of the motor for broken or chipped magnets in the rotor core. Replace motor if magnets are chipped or broken.

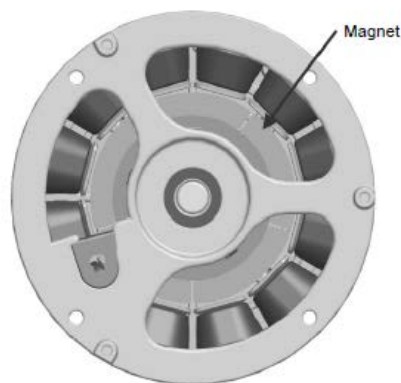

Control Mounting Bracket Service Positioning (RSM Only)

The control mounting bracket has been designed such that it may be rotated upward to allow easier access to make all of the required field connections. To rotate the bracket upward remove the lower positioning bolt as indicated in the figure below. Note this bolt may be on either side of the housing depending upon the furnace model.

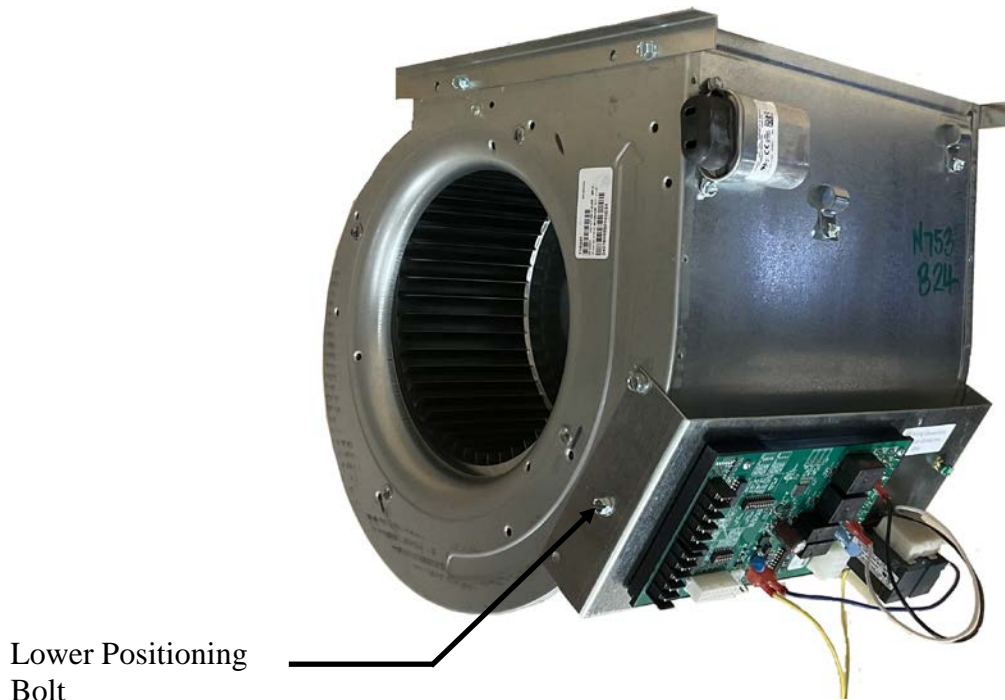

With the lower positioning bolt removed and the bracket rotated upward all of the connections are easily accessible for convenient installation and servicing as shown below.



When finished with wiring and or servicing rotate the bracket to its original position and reinstall the lower positioning bolt.

Hydrolevel OFC-5000 Status Lights

24VAC PWR

Green LED

ON – Indicates proper operation of low voltage transformer.
OFF – No 24 VAC at the board. Check transformer.

24VAC_OVRLD

Red LED

ON - Indicates a short in the low voltage thermostat wiring.
Control will not operate. Unit will reset when the short is
Found and repaired
OFF – Normal operation.

BURNER ON

Orange LED

ON - Indicates burner primary control should be powered.
OFF - Indicates burner should be off.

LIMIT OPEN

Red LED

ON – Furnace high limit open.
Flashing – Furnace high limit reset. Furnace will refire after blower off delay.
OFF – Proper operation.

BLOWER ON

Orange LED

ON – Indicates that the PSC blower should be operational.
OFF – Indicates that the PSC blower should be off.

SYS OK

Green LED

Normal Operation – Slow pulsation

Thermostat Connections

Orange LED

ON - Indicates call from thermostat.
OFF - Indicates no call from thermostat.

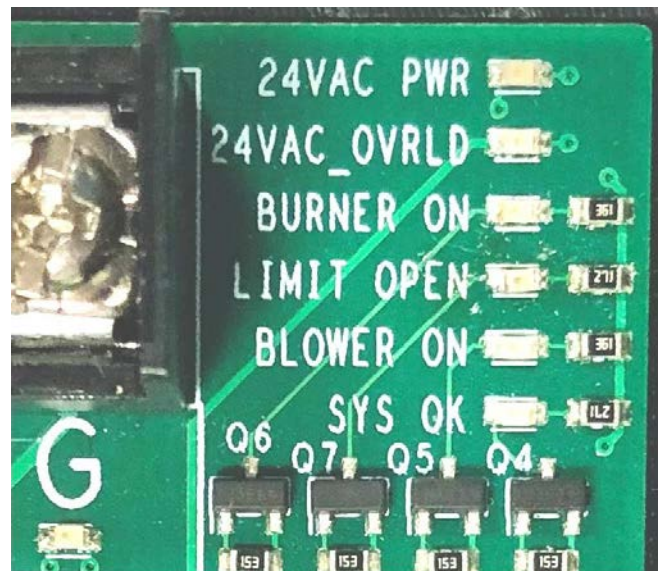

Notes: No lights indicates no power to board or no 24VAC at the board. Incoming power for the furnace must be connected to L1 and N on the Hydrolevel OFC-5000 board. Do not apply power to the 9 pin connector /burner harness.

Boyertown Furnace Limited Warranty

Boyertown Furnace Company, Inc. ("Boyertown") hereby warrants to the original consumer purchaser ("Purchaser") that all equipment manufactured for and bearing Boyertown's nameplate to be free from defects in workmanship or material for a period of years as indicated below under normal use and service at a firing rate of number (2) oil not exceeding that shown on its rating plate on all models of Boyertown Furnace. If any such equipment sold by Boyertown proves to be defective in workmanship and material and if such part is within the indicated months below from the date of original installation returned to our factory, transportation charges prepaid, said part will be replaced or repaired, free of charge, F.O.B. Factory. **Purchaser's remedy shall be limited to such repair or replacement and shall be purchaser's exclusive remedy.**

The purchaser, by acceptance of this equipment, will assume all liability for the consequences of its use or misuse by the purchaser, his employees, and all other persons. All warranties are based upon the return of the defective part to the Factory for examination, and purchaser shall assume responsibility and liability for transportation and labor costs.

Boyertown shall not be liable for any consequential damages resulting from breach of this or any other warranty, express or implied. Some states do not allow the exclusion or limitations on relief such as incidental or consequential damages, so the above limitation or exclusion may not apply to you. Some states do not allow limitations on how long an implied warranty lasts, so the above limitation may not apply to you.

Model	Warranty Period Years	Warranty Period Months
Regal Star	5	60

Heat Exchanger – Residential Single Family Limited Warranty

In addition to the above limited warranty, Boyertown warrants to the original consumer purchaser at the original installation address in a single family dwelling a limited "lifetime" warranty and adjustment policy on the heat exchanger. In the event that any defect in material and workmanship is found to exist by Boyertown Furnace Company within twenty years (20) of the original installation, Boyertown Furnace Company will at its option, with the serial number and proof of purchase by the original consumer purchaser, furnish a replacement, or repair the heat exchanger. In the event that any defect in material and workmanship is found to exist by Boyertown Furnace Company after twenty (20) years of the original installation, Boyertown Furnace Company will at its option, with the serial number and proof of purchase by the original consumer purchaser, provide a new heat exchanger at fifty percent (50%) of the then current list price, or allow a credit in the amount of fifty percent (50%) of the then current list price of an equivalent heat exchanger toward the list price purchase of an equivalent manufactured Boyertown Furnace Company unit. Proof of purchase will be required of the original purchaser when the claim is made. The purchaser must pay all other costs of warranty services, including labor costs involved in diagnostic calls, or in removing, servicing, or replacing warranty parts and or freight charges.

Heat Exchanger – Commercial Limited Warranty

In addition to the above limited warranty, Boyertown warrants to the original consumer purchaser at the original installation address, being other than a single family residence a ten (10) year warranty on the heat exchanger. In the event that any defect in material and workmanship is found to exist by Boyertown Furnace Company within ten years (10) of the original installation, Boyertown Furnace Company will at its option, with the serial number and proof of purchase by the original consumer purchaser, furnish a replacement, or repair the heat exchanger. Proof of purchase will be required of the original purchaser when the claim is made. The purchaser must pay all other costs of warranty services, including labor costs involved in diagnostic calls, or in removing, servicing, or replacing warranty parts and or freight charges.

Any Implied warranty relating to the heat exchanger covered by this warranty, including that of merchantability and fitness for a particular purpose shall be limited to the period of this limited warranty.

Boyertown shall not be liable for any consequential damages resulting from breach of this or any other warranty, express or implied. Some states do not allow the exclusion or limitations on relief such as incidental or consequential damages, so the above limitation or exclusion may not apply to you. Some states do not allow limitations on how long an implied warranty lasts, so the above may not apply to you.

Purchasers Responsibilities

In the event the original consumer purchaser believes there is a defect in material or workmanship, he shall, within thirty (30) days of the discovery of the defect, notify Boyertown in writing. Boyertown or its authorized representative at its option will inspect the furnace and its component parts to determine whether a defect exists and recommend repair or replacement if necessary under the terms of the warranty. If Boyertown determines that no such defect exists, purchaser may still pursue its remedies by commencing a civil action, but must do so **within (1) year after the cause occurred.** Some states do not allow this (1) year limitation, so it may not be applicable to you.

This warranty will not be applicable if the furnace has been damaged as a result of being improperly serviced, or operated, including but not limited to the following:

- A) If the furnace is used or operated over its rated capacity, as shown on the rating plate, or installed for uses other than residential home heating or commercial heating as listed above.
- B) The furnace not being connected to an adequate sized supply and return air ducts according to industry standards and/or restrictions of air flow through the furnace and duct system.
- C) Furnace must be operated in an environment free from the effects of chlorinated hydrocarbons.
- D) Furnace not being operated during each heating season.
- E) Damages, defects or other losses that occur in anyway after the furnace or heat exchanger has been tampered with, or altered in any way, except as may be specifically directed in writing by Boyertown Furnace Company, and damages, defects or other losses arising from improper installation, adjustment or servicing of the furnace or heat exchanger.
- F) No warranty is given to any equipment which has not been installed by a qualified installer according to the regulations of the National Fire Protection Standard for Oil Burning Equipment, NFPA No. 31 and in complete accordance with all existing local codes, regulations, ordinances, and authorities having jurisdiction. A qualified installer is an individual or agency responsible for the installation and adjustment of oil burning equipment. The installer should be licensed and experienced to perform the installation of such equipment according to all codes and ordinances.
- G) This warranty does not cover expenses for the removal or reinstallation. The purchaser shall be responsible for the cost of removing and reinstalling the defective part including labor and material connected therewith. Upon request of Boyertown, it shall be the obligation of the purchaser to ship prepaid to Boyertown the defective part for inspection or repair.
- H) This warranty is applicable only to defects in material and workmanship and shall not cover failure of the furnace or any of its component parts due to any other reason including, but not limited to (1) lack of sufficient air flow, (2) floods, (3) fire, (4) acts of God, (5) negligent or improper installation, (6) corrosion of heat exchanger surfaces, (7) leaky gaskets, (8) improper maintenance of external and fire side surfaces.

Installation and Service Check List

Furnace Model: _____ Serial No.: _____

Installation Date: _____

Installer Name: _____ Phone No.: _____

Furnace Installation

- Furnace level and in solid contact with floor?
- Furnace and burner wired per wiring diagram and National Electric Code? 120VAC wiring Type _____ Size _____ AWG
- Burner sealed to furnace? Mounting nuts tight?
- Space is large enough to provide required clearances?
- NFPA 31 Installation of Oil Burning Equipment followed?
- Local, state and national codes, laws, regulations and ordinances followed?

Vent System

- Existing chimney and vent system inspected to NFPA 211 and in good condition?
- New vent pipe installed and properly sealed?
- Vent size checked against furnace manual and codes?

Duct Work

- Return and supply ducts checked for size based on furnace air flow and ACCA Manual D?
- All ducts sealed and insulated as required?

Burner Operation

- Burner Model: _____ Nozzle: _____ GPH _____ Deg. _____ Type _____
- Burner Pump Pressure: _____
- Fuel filter and fuel lines installed and inspected as per burner manual?
- Air bled from oil piping? Piping checked for leaks?
- Burner started, adjusted and tested per burner manual?

Furnace Operation

- Thermostat heat anticipator set per burner manual instructions?
- Temperature rise through the furnace checked 60°F maximum and blower speed adjusted as required?
- Blower motor amperage does not exceed rated full load amperage?
- Clean air filter installed?
- Limit control tested for proper operation?
- Furnace observed going through several operational cycles for proper operation?

Post Installation

- Reviewed owners' information in this manual with owner or maintenance personnel and instructed to keep for future reference?
- Properly filled in and returned warranty registration card to Boyertown Furnace Co.
Inserted burner manual instructions with furnace manual for future use?

✂ -----Cut and Return This Form or Register Online at www.boyertownfurnace.com-----

Boyertown Furnace Co.

P.O. Box 100

Boyertown, PA 19512

Date Installed: _____

Furnace Model: _____

Serial Number: _____

Name of Purchaser: _____

Purchaser's Address: _____

Dealer's Name: _____

Dealer's Address: _____
