

# INSTALLATION INSTRUCTIONS

R950, R950SS

## Flash™ Rough Valve Kit

Thank you for selecting American-Standard...  
the benchmark of fine quality for over 140 years.

To ensure that your installation proceeds smoothly-please read these instructions carefully before you begin.

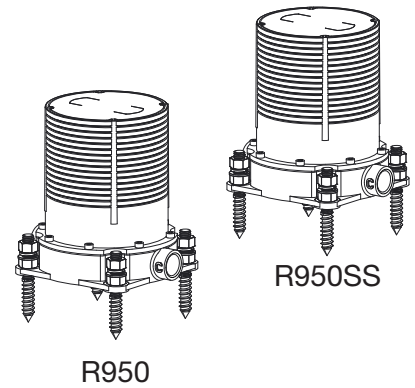

Certified to comply with ASME A112.18.1/CSA B125.1

### RECOMMENDED TOOLS

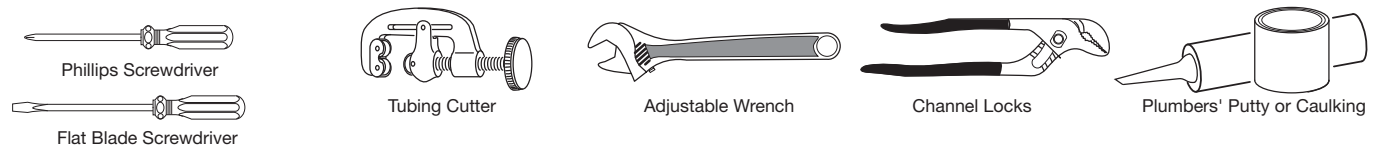

### ROUGHING-IN DIMENSIONS

■ To assure proper positioning in relation to wall, note roughing-in dimensions.

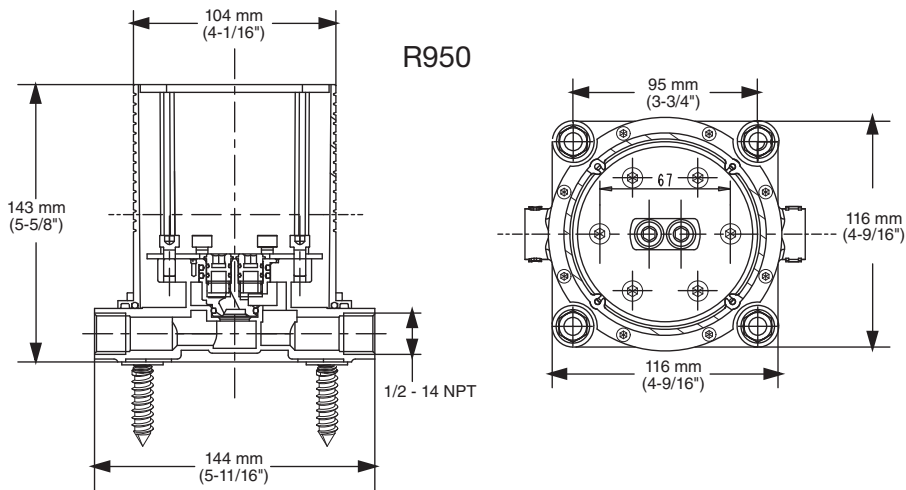

R950

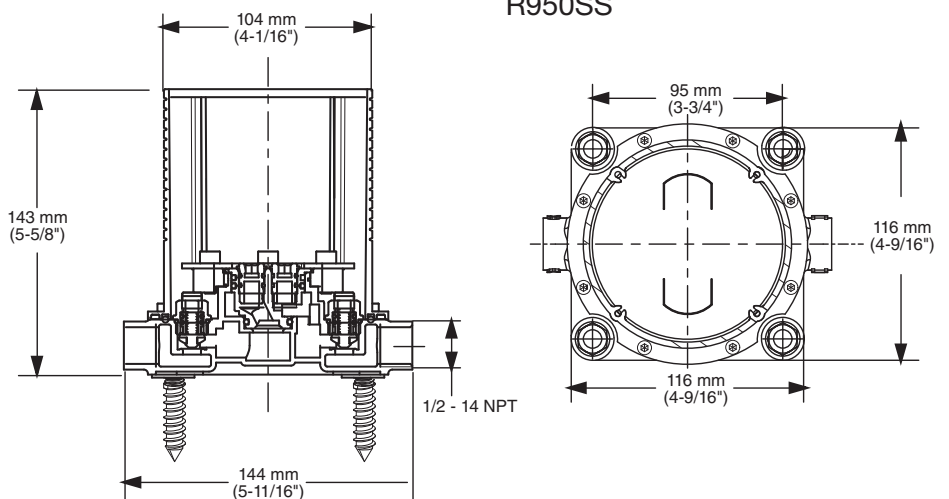

R950SS

## 1 INSTALL TUB FILLER FLOOR SUPPORT

### CAUTION

Turn off hot and cold water supplies before beginning.

- **Note:** Refer to Roughing-in Dimensions on page 1 for additional information.
- Adequate floor support is required. The WOOD SUPPORT (1) must be a minimum of 2" (51 mm) thick by 10" (254 mm) wide. 2x6 lumber is **NOT** adequate for this application.
- Locate WOOD SUPPORT (1) between floor joists keeping a minimum distance of 2-3/4" (70 mm) from the top surface of wood support to the finished floor.
- **IMPORTANT:** Use a ROUND BUBBLE LEVEL (2) to level the WOOD SUPPORT (1). The WOOD SUPPORT (1) must be perfectly level. Secure WOOD SUPPORT (1) to floor joists. Check for level again.

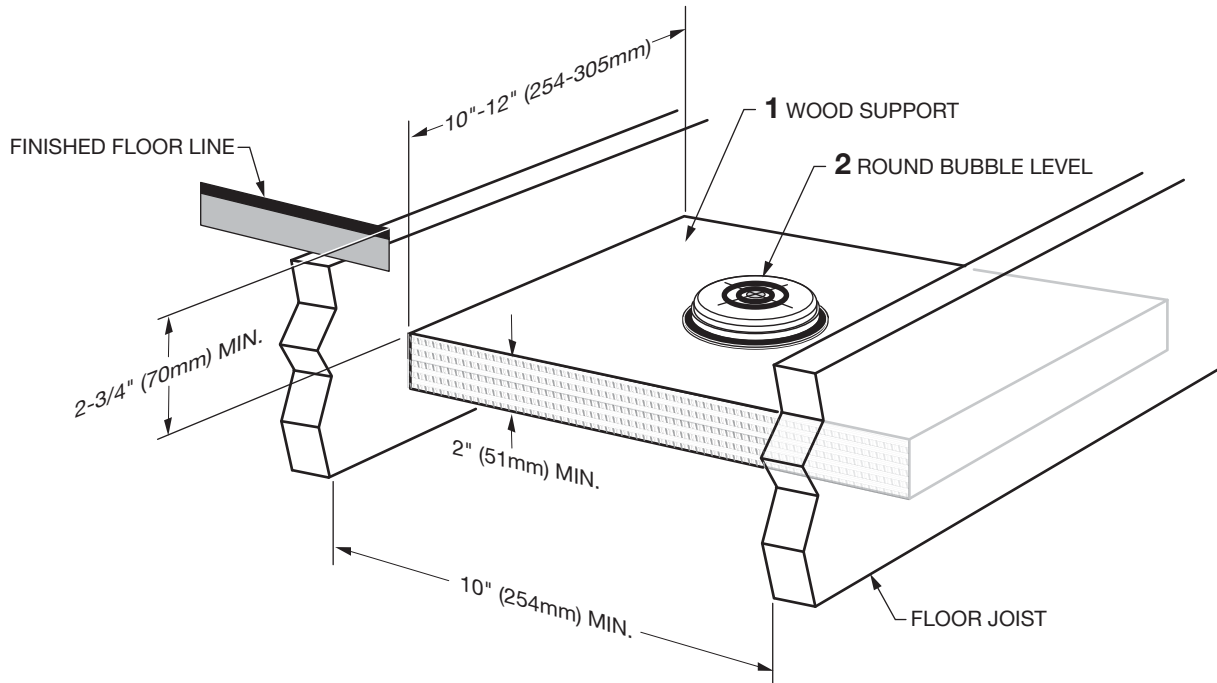

## 2 INSTALL HOT AND COLD WATER SUPPLIES

- Sweat together Hot and Cold Supply assemblies. Apply sealing tape to threaded connections. Thread supply assemblies into rough-in valve inlets. The Hot inlet will be on the left when facing the front of the Tub Filler.

**Note:** The Hot and Cold inlets are marked on the manifold. See View "A".

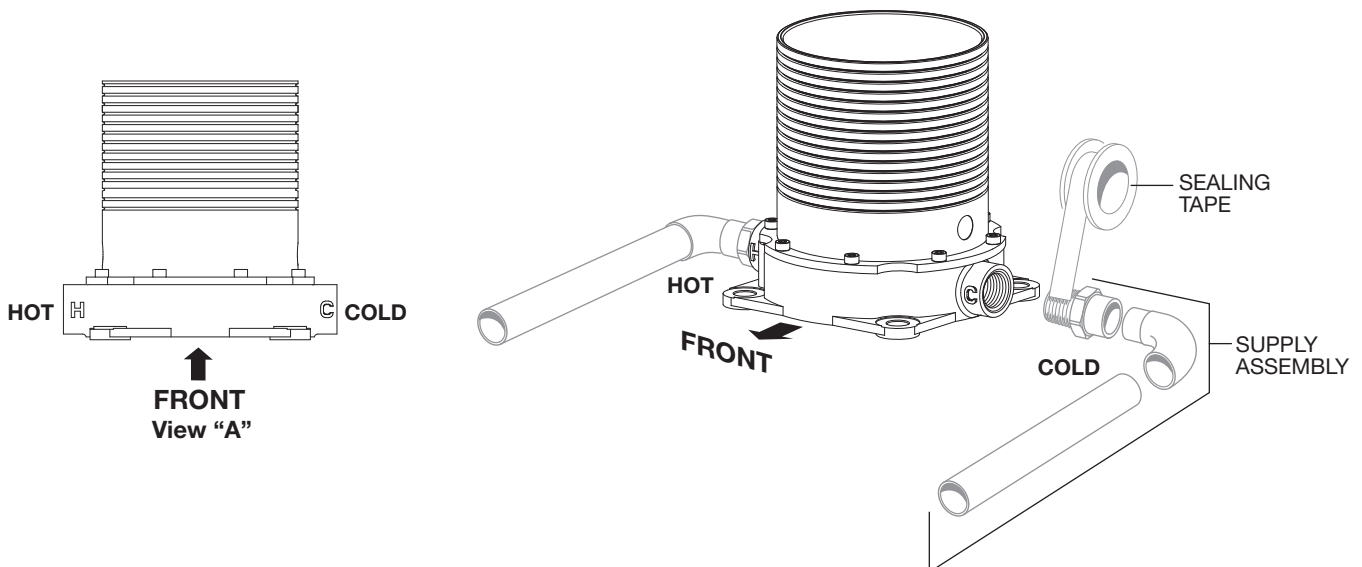

### 3 INSTALL ROUGH-IN VALVE

- Locate the position on the wood support where the ROUGH-IN VALVE (1) will be installed. Use the ROUGH-IN VALVE (1) as a guide to mark the four mounting hole locations. **Fig. 1.**
- Remove ROUGH-IN VALVE (1) and drill four pilot holes of 3/8" (9 mm) in diameter. **Fig 2.**
- Install the 4 MOUNTING SCREWS (2) into wood support.
- Install ROUGH-IN VALVE (1) onto the 4 MOUNTING SCREWS (2) and tighten NUTS & WASHERS (2) supplied.

**\*Important: FRONT of ROUGH-IN VALVE (1) must face bath rim. Figure 1.**

#### NOTE: IF INSTALLING ON A CONCRETE SLAB

- Drill four pilot holes of 12.5 mm (1/2") in diameter.
- Insert a concrete anchor in each pilot hole.
- Install the 4 MOUNTING SCREWS (2) into the 4 concrete anchors. Tighten NUTS & WASHERS (2) supplied.
- \* Concrete anchor not included. But available commercially.

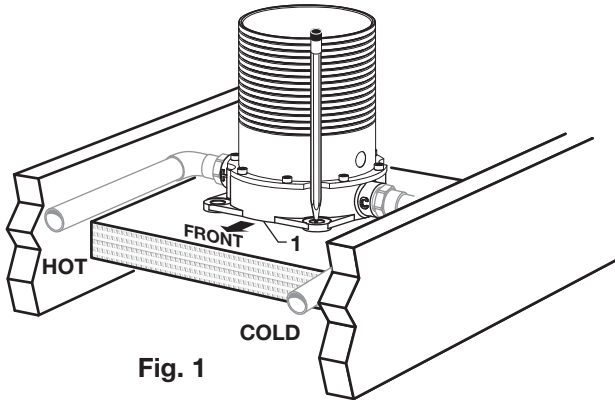
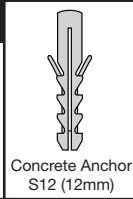

Fig. 1

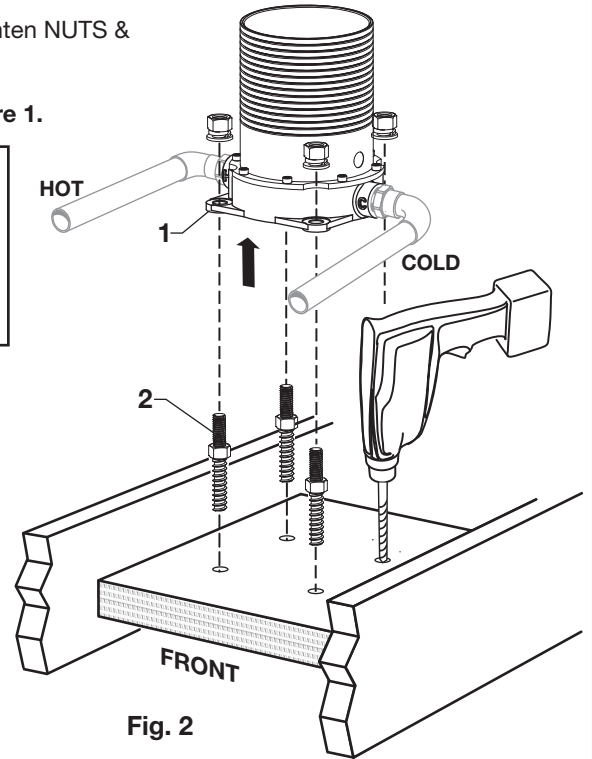

Fig. 2

### 4 LEVEL ROUGH-IN VALVE

- Check that top of the ROUGH-IN VALVE (1) is level in all directions. If the ROUGH-IN VALVE (1) is not level follow the steps below.
- 1. Loosen the four MOUNTING NUTS (2).
- 2. Adjust the LEVELING NUTS (2a) until the TUB FILLER is level in all directions.
- 3. Tighten the four MOUNTING NUTS (2) and check that the TUB FILLER is still level. If adjustment is still required loosen MOUNTING NUTS (2) and adjust LEVELING NUTS (2a).
- Verify that the ROUGH-IN VALVE (1) is level and then fully tighten NUTS & WASHERS (2).

#### FINISH PLUMBING CONNECTIONS

- Complete all Hot and Cold supply connections.
- Turn on water supplies and check for leaks.

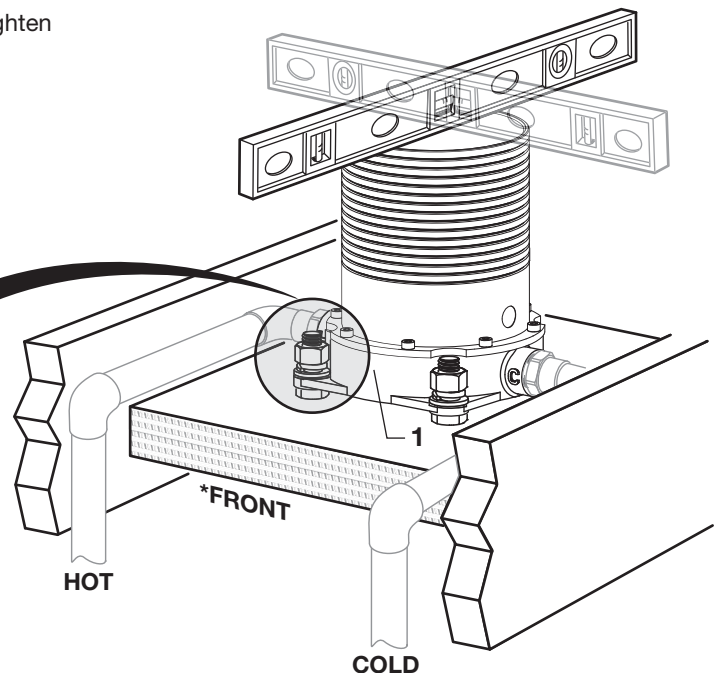
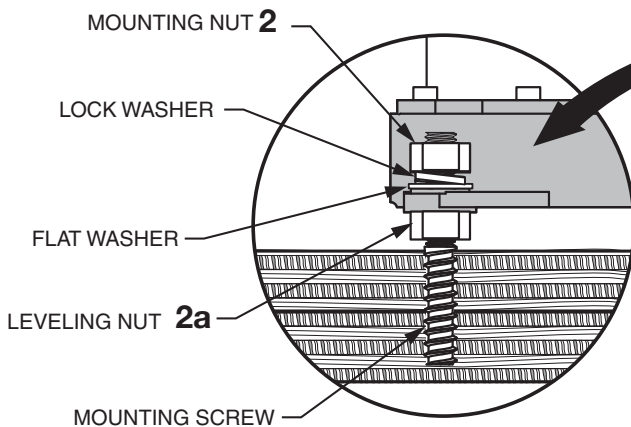

## 5 FINISH FLOOR INSTALLATION

- Complete the installation of the Finished Floor. Tile as close to the PLASTER GUARD (3) as you can.
- Caulk between Finished Floor and PLASTER GUARD (3).

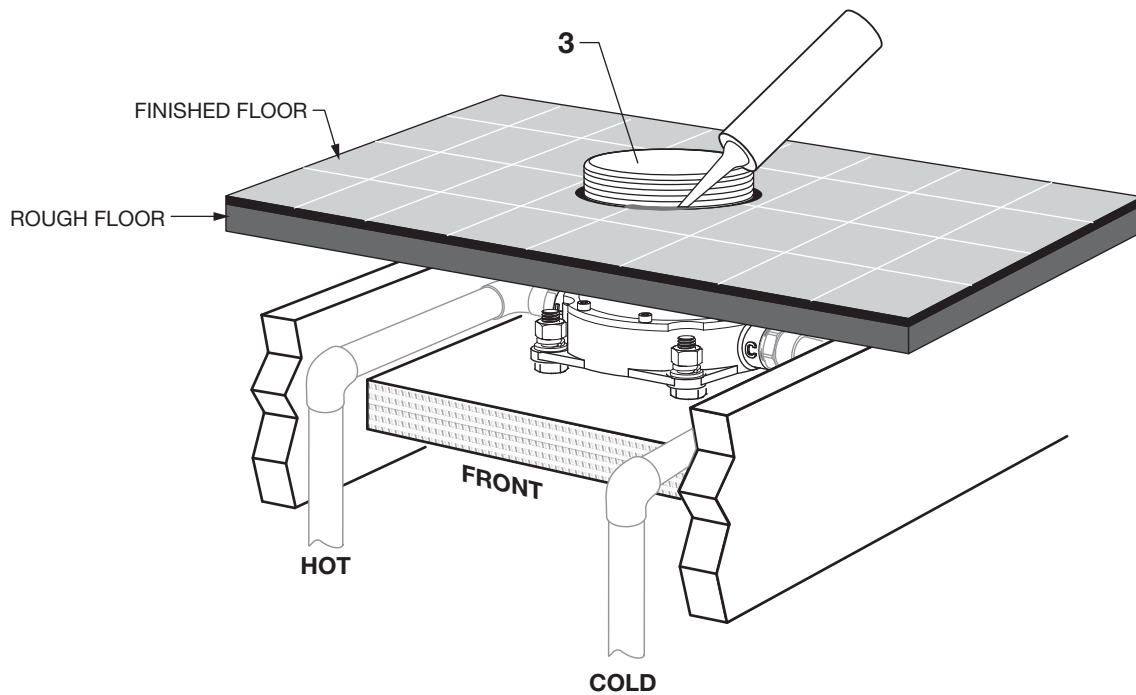

# American Standard

## Flash™ Rough Valve Kit

MODEL NUMBERS

**R950**  
**R950SS**

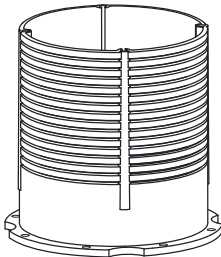
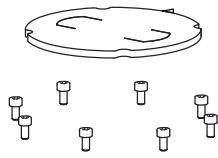

**R950**

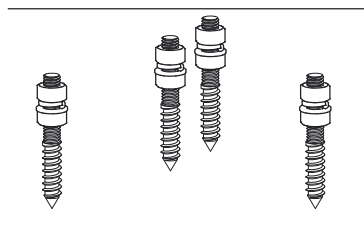
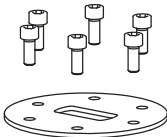

**M970513-0070A**  
MOUNTING SCREW KIT

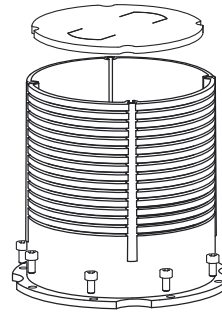
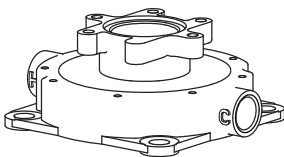

**R950SS**

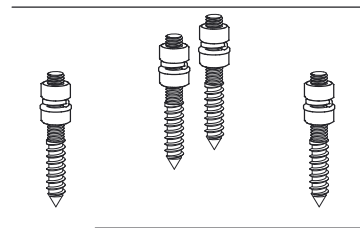

**M970513-0070A**  
MOUNTING SCREW KIT

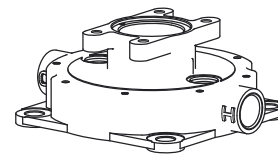

### HOT LINE FOR HELP

For toll-free information and answers to your questions, call:  
1 (800) 442-1902

Mon. - Fri. 8:00 a.m. to 8:00 p.m. EST  
Saturday 10:00 a.m. to 4:00 p.m. EST

IN CANADA 1-800-387-0369  
(TORONTO 1-905-306-1093)

Weekdays 8:00 a.m. to 7:00 p.m. EST

IN MEXICO 01-800-839-1200



Product names listed herein are  
trademarks of AS America, Inc.  
© AS America, Inc. 2018

PART OF **LIXIL**