



# Phoenix Series

## Gas Fired Water Heaters

**Installation**

**Start-Up**

**Maintenance**

**Parts**

**Warranty**

**PH100 / PH130 / PH160 / PH199 Models\***

\* "LP" Denotes Propane Gas Operation

"S" Denotes Solar Models

"SA" Denotes Sanitizer Booster Models

"M" Denotes Multi Fit Models

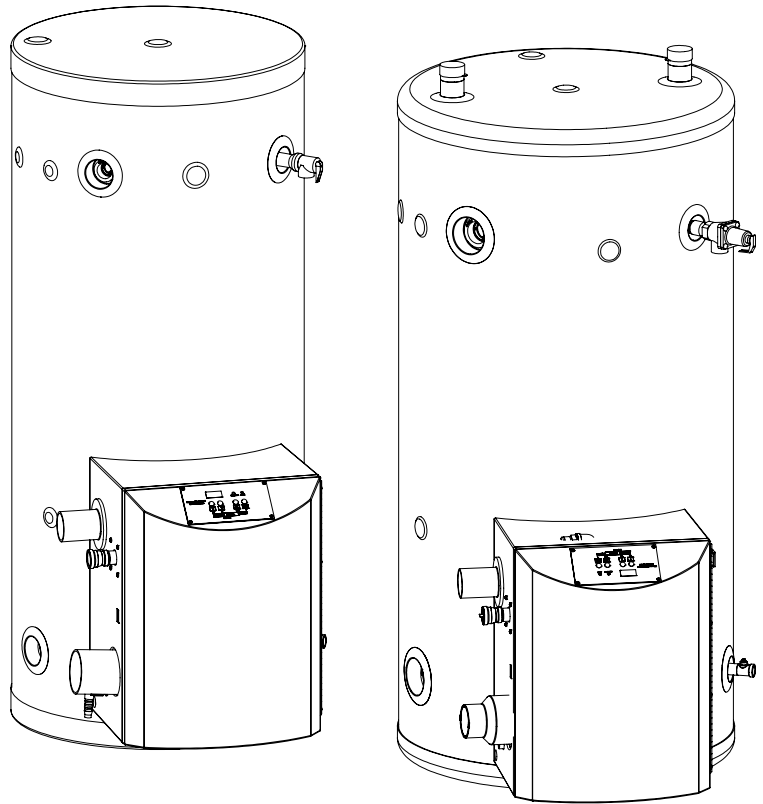

This Manual For Use With Water Heaters Manufactured After September 1, 2021



### **! DANGER**

This manual must only be used by a qualified installer / service technician. Read all instructions in this manual before installing. Perform steps in the given order. Failure to do so could result in substantial property damage, severe personal injury, or death.

### **! WARNING**

Improper installation, adjustment, alteration, service, or maintenance could void product warranty and cause property damage, severe personal injury, or death.

California Proposition 65 Warning: This product contains chemicals known to the State of California to cause cancer, birth defects, or other reproductive harm.

### **NOTICE**

HTP reserves the right to make product changes or updates without notice and will not be held liable for typographical errors in literature.

The surfaces of these products contacted by potable (consumable) water contain less than 0.25% lead by weight as required by the Safe Drinking Water Act, Section 1417.

**NOTE TO CONSUMER: PLEASE KEEP ALL INSTRUCTIONS FOR FUTURE REFERENCE.**

## ! WARNING

WARNING: If the information in these instructions is not followed exactly, a fire or explosion may result causing property damage, personal injury or death.

- Do not store or use gasoline or other flammable vapors and liquids in the vicinity of this or any other appliance.

### WHAT TO DO IF YOU SMELL GAS

- Do not try to light any appliance.
- Do not touch any electrical switch; do not use any phone in your building.
- Immediately call your gas supplier from a neighbor's phone. Follow the gas supplier's instructions.
- If you cannot reach your gas supplier, call the fire department.
- Installation and service must be provided by a qualified installer, service agency or the gas supplier.

**Improper installation, adjustment, alteration, service, or maintenance can cause injury, property damage, or death. Refer to this manual. Installation and service must be performed by a qualified installer, service agency, or gas supplier.**

## FOR YOUR SAFETY READ BEFORE OPERATING

**WARNING: If you do not follow these instructions exactly, a fire or explosion may result, causing property damage, personal injury or loss of life.**

- A. This appliance does not have a pilot. It is equipped with an ignition device which automatically lights the burner. Do not try to light the burner by hand.
- B. BEFORE OPERATING smell all around the appliance area for gas. Be sure to smell next to the floor because some gas is heavier than air and will settle on the floor.

### WHAT TO DO IF YOU SMELL GAS

- Do not try to light any appliance
- Do not touch any electric switch; do not use any phone in your building
- Immediately call your gas supplier from a neighbor's phone. Follow the gas suppliers' instructions.

- If you cannot reach your gas supplier, call the fire department.
- C. Use only your hand to turn the gas control knob. Never use tools. If the handle will not turn by hand, don't try to repair it, call a qualified service technician. Force or attempted repair may result in a fire or explosion.
- D. Do not use this appliance if any part has been under water. Immediately call a qualified service technician to inspect the appliance and to replace any part of the control system and any gas control which has been under water.

## OPERATING INSTRUCTIONS

1. STOP! Read the safety information above.
2. Set the thermostat to lowest setting.
3. Turn off all electric power to the appliance.
4. This appliance is equipped with an ignition device which automatically lights the burner. Do not try to light the burner by hand.
5. Remove front cover.
6. Turn gas shutoff valve to "off". Handle will be across the piping, do not force.
7. Wait five (5) minutes to clear out any gas. If you then smell gas, STOP! Follow "B" in the safety information above on this label. If you don't smell gas, go to next step.
8. Turn gas shutoff valve to "on". Handle will be in line with piping.
9. Install Front Cover.
10. Turn on all electric power to appliance.
11. Set thermostat to desired setting.
12. If the appliance will not operate, follow the instructions "To Turn Off Gas To Appliance" and call your service technician or gas supplier.

GAS VALVE  
ON

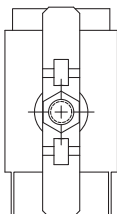

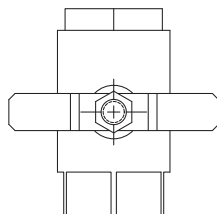

GAS VALVE  
OFF



## TO TURN OFF GAS TO APPLIANCE

1. Set the thermostat to lowest setting.
2. Turn off all electric power to the appliance if service is to be performed.
3. Remove Front Cover.
4. Turn gas shutoff valve to "off". Handle will be across the piping. Do not force.
5. Install Front Cover.

LP-175 Rev. 4 3-11-08

<b>SPECIAL ATTENTION BOXES</b>	
The following defined terms are used throughout this manual to bring attention to the presence of hazards of various risk levels or to important product information.	
 <b>DANGER</b>	
<b>DANGER</b> indicates an imminently hazardous situation which, if not avoided, will result in serious personal injury or death.	
 <b>WARNING</b>	
<b>WARNING</b> indicates a potentially hazardous situation which, if not avoided, could result in personal injury or death.	
 <b>CAUTION</b>	
<b>CAUTION</b> indicates a potentially hazardous situation which, if not avoided, may result in moderate or minor personal injury.	
<b>CAUTION</b>	
<b>CAUTION used without the safety alert symbol</b> indicates a potentially hazardous situation which, if not avoided, may result in property damage.	
<b>NOTICE</b>	
<b>NOTICE</b> is used to address practices not related to personal injury.	

**Foreword**

This manual is intended to be used in conjunction with other literature provided with the water heater. This includes all related control information. It is important that this manual, all other documents included in this system, and additional publications including the *National Fuel Gas Code - ANSI Z223.1* (latest versions), be reviewed in their entirety before beginning any work.

Installation should be made in accordance with the regulations of the Authority Having Jurisdiction, local code authorities, and utility companies which pertain to this type of water heating equipment.

Authority Having Jurisdiction (AHJ) – The AHJ may be a federal, state, local government, or individual such as a fire chief, fire marshal, chief of a fire prevention bureau, labor department or health department, building official or electrical inspector, or others having statutory authority. In some circumstances, the property owner or his/her agent assumes the role, and at government installations, the commanding officer or departmental official may be the AHJ.

**NOTE:** HTP reserves the right to modify product technical specifications and components without prior notice.

**For the Installer**

This water heater must be installed by qualified and licensed personnel. The installer should be guided by the instructions furnished with the water heater, and by local codes and utility company requirements. In the absence of local codes, preference should be given to the *National Fuel Gas Code - ANSI Z223.1* in the United States and the *Natural Gas and Propane Installation Code - B149.1* in Canada (latest versions).

**Installations Must Comply With:**

Local, state, provincial, and national codes, laws, regulations, and ordinances.

In the United States - The latest version of the *National Fuel Gas Code, ANSI Z223.1*, from American Gas Association Laboratories, 8501 East Pleasant Valley Road, Cleveland, OH 44131.

The latest version of the *National Electrical Code, NFPA No. 70*.

In Canada - The latest versions of the *Natural Gas and Propane Installation Code, CSA B149.1*, and the *Canadian Electrical Code, C22.1*, from CSA Group, 178 Rexdale Blvd, Toronto, Ontario, Canada M9W 1R3.

**NOTE:** The gas manifold and controls met safe lighting and other performance criteria when undergoing tests specified in *ANSI Z21.13* - latest edition.

 **DANGER**



**▲ Vapors from flammable liquids will explode and catch fire causing death or severe burns.**  
Do not use or store flammable products such as gasoline, solvents or adhesives in the same room or area near the water heater.

**Keep flammable products:**

1. far away from heater,
2. in approved containers,
3. tightly closed and
4. out of children's reach.

Water heater has a main burner and pilot flame. The pilot flame:

1. which can come on at any time and
2. will ignite flammable vapors.

**Vapors:**

1. cannot be seen,
2. are heavier than air,
3. go a long way on the floor and
4. can be carried from other rooms to the pilot flame by air currents.

**Installation:**  
Do not install water heater where flammable products will be stored or used unless the main burner and pilot flames are at least 18" above the floor. This will reduce, but not eliminate, the risk of vapors being ignited by the main burner or pilot flame.

Read and follow water heater warnings and instructions. If owners manual is missing, contact the retailer or manufacturer.

 **DANGER**

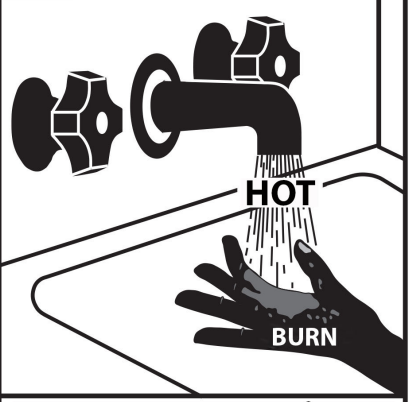

Water temperature over 125°F can cause severe burns instantly or death from scalds. Children, disabled and elderly are at highest risk of being scalded. See instruction manual before setting temperature at water heater. Feel water before bathing or showering. Temperature limiting valves are available, see manual.

## **WARNING**

### **From the Uniform Plumbing Code 2000 - Section 510 - Protection From Damage**

1. Water heaters generating a glow, spark or flame capable of igniting flammable vapors may be installed in a garage, provided the pilots, burners or heating elements and switches are at least eighteen (18) inches (457 mm) above the floor level.
2. Where such water heaters installed within a garage are enclosed in a separate, approved compartment having access only from outside of the garage, such water heaters may be installed at floor level provided the required combustion air is also taken from the exterior of the garage. Fuel burning water heaters having sealed combustion chambers need not be elevated.
3. All water heaters installed in areas where they may be subjected to mechanical damage shall be suitably guarded against such damage by being installed behind adequate barriers or by being elevated or located out of the normal path of a vehicle using any such garage.
4. In seismic zones 3 and 4, water heaters shall be anchored or strapped to resist horizontal displacement due to earthquake motion. Strapping shall be at points within the upper one-third (1/3) and lower one-third (1/3) of its vertical dimensions. At the lower point, a minimum distance of four (4) inches (102 mm) shall be maintained above the controls with the strapping.
5. An water heater supported from the ground shall rest on level concrete or other approved base extending not less than three (3) inches (76 mm) above the adjoining ground level.
6. When an water heater is located in an attic, attic-ceiling assembly, floor-ceiling assembly, or floor-subfloor assembly where damage may result from a leaking water heater, a watertight pan of corrosion resistant materials shall be installed beneath the water heater with a minimum three-quarter (3/4) inch (20 mm) diameter drain to an approved location.

#### **Table of Contents**

<b>Part 1 - General Safety Information</b>	<b>5</b>	D. Temperature and Pressure Relief Valve	15
A. Operation and Installation Warnings	5	E. Scalding	16
B. Improper Combustion	6	F. Filling the Heater	16
C. Gas	6	G. Applications	17
D. When Servicing the Water Heating System	6	<b>Part 5 - Venting</b>	<b>21</b>
E. Water Chemistry Requirements	6	A. General	21
F. Freeze Protection	7	B. Approved Materials for Exhaust Vent and Intake Pipe	22
G. Water Temperature Adjustment	7	C. Additional Requirements for Installation in Canada	22
H. High Elevation Installations	7	D. Exhaust Vent and Intake Pipe Location	23
<b>Part 2 - Before You Start</b>	<b>8</b>	E. Exhaust Vent and Intake Pipe Sizing	24
A. What's in the Box	8	F. Longer Vent Runs	24
B. How the Heater Operates	8	G. Exhaust Vent and Intake Pipe Installation	24
C. Optional Equipment	8	H. Applications	25
<b>Part 3 - Prepare the Water Heater</b>	<b>8</b>	1. Direct Vent Installation of Exhaust and Intake	25
A. Locating the Water Heater	8	2. Venting Through an Existing System	29
B. Leveling	9	3. Power Venting, Indoor Combustion Air in Confined or Unconfined Space	30
C. Clearances for Service Access	10	<b>Part 6 - Condensate Removal</b>	<b>31</b>
D. Residential Garage and Closet Installations	10	<b>Part 7 - Wiring</b>	<b>32</b>
E. Exhaust Vent and Intake Pipe	10	A. Line Voltage Input	32
1. Direct Vent of Exhaust and Intake	11	B. Line Voltage Condensate Output	32
2. Power Venting, Indoor Combustion Air in Confined or Unconfined Space	11	C. Low Voltage Outdoor Sensor Input	32
F. Carbon Monoxide Detectors	11	D. Alarm Connections	32
G. Prevent Combustion Air Contamination	11	E. Optional 0-10 Volt Building Control Signal	32
H. Removing a Heater from a Common Vent System	12	F. Internal Wiring Diagram	33
I. Anode Rod	12	<b>Part 8 - Gas Connections</b>	<b>35</b>
<b>Part 4 - Piping</b>	<b>15</b>	A. Gas Pipe Sizing Tables	35
A. General Plumbing Information	15	1. Gas Pipe Sizing	35
B. Backflow Preventer	15	2. Natural Gas Pipe Sizing	35
C. Potable Expansion Tank	15	3. LP (Liquid Propane) Gas Pipe Sizing	35
		B. Gas Connection Requirements	36
		C. Additional Precaution for Excess Flow Valve (EFV)	36
		D. Gas Valve	37
		E. Checking Gas Pressure at the Water Heater for Proper Operation	37
		<b>Part 9 - Start-Up Preparation</b>	<b>38</b>
		A. Check / Control Water Chemistry	38
		B. Check for Gas Leaks	38
		C. Fill and Test Water System	38
		D. Condensate Removal	38
		<b>Part 9 - Start-Up Procedure</b>	<b>39</b>
		A. Operating Instructions	39
		B. Overall Water Heater and Control Operation	39
		C. Status Menu	39
		D. Outdoor Reset	39
		E. Test Mode	40
		F. Maintenance	40
		<b>Part 10 - Shutdown</b>	<b>41</b>
		A. Shutdown Procedure	41
		B. Vacation Procedure	41
		C. Failure to Operate	41
		D. Important Notice	41
		<b>Part 11 - Troubleshooting</b>	<b>42</b>
		A. Error Code	42
		B. Heater Error	42
		C. Lockout	42
		<b>Part 12 - Installation Checklist</b>	<b>44</b>
		<b>Part 13 - Maintenance</b>	<b>45</b>
		<b>Part 14 - Replacement Parts</b>	<b>48</b>
		Limited Warranty	51
		Massachusetts Supplemental Commercial Use Warranty	53
		For Multiple Water Heater Installations	53
		Maintenance Notes	55
		Customer Installation Record Form	56

### Part 1 - General Safety Information

This water heater is approved for indoor installations only and is not intended for use as a pool heater. Clearance to combustible materials: 0" top, bottom, sides, and back. Heater must have room for service: 24" front and 12" sides are minimum recommended service clearances. (A combustible door or removable panel is acceptable front clearance.) This water heater has been approved for closet installation and installation on combustible flooring. Do not install directly on carpeting. Install the water heater in a location where temperature and pressure relief valve discharge or a leak will not result in damage to the surrounding area. If such a location is not available install an auxiliary catch pan.

This appliance is rated Category IV (pressurized vent, likely to form condensate in the vent) and requires a special vent system designed for pressurized venting. **Use only Category IV vent systems.**

 <b>WARNING</b>
<b>Installer</b> - Read all instructions in this manual before installing. Perform steps in the given order.
<b>User</b> - This manual is for use only by a qualified heating installer / service technician. Have this water heater serviced / inspected annually by a qualified service technician.
<b>FAILURE TO ADHERE TO THE GUIDELINES ON THIS PAGE CAN RESULT IN SUBSTANTIAL PROPERTY DAMAGE, SEVERE PERSONAL INJURY, OR DEATH.</b>
<b>NOTE:</b> Obey all local codes. Obtain all applicable permits before installing the water heater.
<b>NOTE:</b> Install all system components and piping in such a manner that does not reduce the performance of any fire rated assembly.

#### A. Operation and Installation Warnings

To avoid serious injury or death, read, understand, and follow all of the precautions listed here.

 <b>DANGER</b>
Vapors from flammable liquids will explode and cause a fire, resulting in personal injury or death. The water heater has a burner that can come on at any time and ignite vapors. DO NOT use or store flammable liquids around the water heater.
Improper venting can cause a build-up of carbon monoxide. Breathing carbon monoxide can result in brain damage or death. DO NOT operate the water heater unless it is properly vented to the outside and has an adequate fresh air supply for safe operation. Inspect the exterior exhaust gas outlet port and fresh air inlet port on a regular basis to ensure they are functioning properly.
A concentration of carbon monoxide as small as .04% (400 parts per million) in the air can be fatal. When making high fire or low fire adjustments, CO levels must be monitored using a calibrated combustion analyzer such that a CO level of no more than 150 ppm is exceeded at any time during operation.
Adjusting the "low fire offset" or the "main flow restrictor" in small increments can result in a significant increase in CO concentration. To avoid serious injury or death, DO NOT make any adjustments to the gas valve without monitoring the exhaust gases with a fully functional and calibrated combustion analyzer.
Failure to follow these instructions will result in property damage, severe personal injury, or death.

 <b>WARNING</b>
This water heater must be installed by a licensed plumber, licensed gas fitter, and/or professional service technician. Improper installation and/or operation can cause a potentially hazardous situation, which, if not avoided, could result in serious injury or death, and will void the warranty.
The manufacturer cannot anticipate every circumstance that might involve a potential hazard. Each installation has its own specialized characteristics, requirements, and possible hazards. Therefore, all possible incidents are not included in these warnings. Proper and safe installation, operation, and service are the responsibility of the qualified service technician.
Proper care of the water heater is the user's responsibility. Ensure the user carefully reads and understands the User's Information Manual before operating the water heater.
Make sure the user knows the location of the gas shut-off valve and how to operate it. Immediately close the gas shut-off valve if the appliance is subjected to fire, overheating, flood, physical damage, or any other damaging condition that might affect the operation of the unit. Have the appliance checked by a qualified service technician before resuming operation.
Do not power up the unit unless the gas and water supply valves are fully opened. Make sure the fresh air intake port and exhaust gas port are open and functional.
No one but a qualified service technician should attempt to install, service, or repair this water heater. There are no serviceable parts which can be changed by the user / owner.
User / Owner: Contact the original qualified service technician if the water heater needs repair / maintenance. If the original technician is unavailable, ask your gas supplier for a list of qualified service providers.
DO NOT store or place newspapers, laundry, or other combustible items near the appliance or the exterior exhaust gas outlet and/or fresh air inlet port.
The owner should inspect the system monthly for damage, water stains, signs of rust, corrosion, and exhaust vent and air intake blockage. If inspection of the unit shows signs of damage, the water heater should be shut off until the problem is repaired by a qualified technician.
After installation, all appliance safety devices should be tested.
Carefully consider installation location and the placement of critical components (circulators, condensate neutralizers, etc.) before installing the water heater.
DO NOT allow children to operate this water heater. DO NOT use this water heater if it does not appear to be operating correctly. A qualified service technician should service and inspect the water heater annually.
<b>NOTE:</b> If the water heater is exposed to fire or water (or is any way damaged), do not operate. Immediately call a qualified service technician. Failure to follow this information could result in property damage, severe personal injury, or death.
<b>DO NOT USE THIS WATER HEATER IF ANY PART HAS BEEN SUBMERGED IN WATER.</b> Immediately call a qualified service technician. The water heater MUST BE replaced if it has been submerged. Attempting to operate a water heater that has been submerged could create numerous harmful conditions, such as a potential gas leakage causing a fire and/or explosion, or the release of mold, bacteria, or other harmful particulates into the air. Operating a previously submerged water heater could result in property damage, severe personal injury, or death.
<b>NOTE:</b> Water heater damage due to flood or submersion is considered an Act of God, and IS NOT covered under product warranty.

## **WARNING**

The appliance is certified for indoor installations only. The appliance consists of gas ignition system components which must be protected from water (dripping, spraying, etc.) during operation and service. Carefully consider installation location and the placement of critical components (circulators, condensate neutralizers, etc.) before installing the appliance.

DO NOT alter or modify the appliance or appliance controls. Altering any HTP water heater with parts not manufactured by HTP WILL INSTANTLY VOID the water heater warranty and could result in property damage, personal injury, or death.

This water heater has been designed to heat potable water ONLY. Using this water heater to heat non-potable fluid WILL VOID product warranty, and could result in property damage, personal injury, or death.

## **CAUTION**

High heat sources (sources generating heat 100°F / 37°C or greater, such as stove pipes, space heaters, etc.) may damage plastic components of the water heater as well as plastic vent pipe materials. Such damages ARE NOT covered by warranty. It is recommended to keep a minimum clearance of 8" from high heat sources. Observe heat source manufacturer instructions, as well as local, state, provincial, and national codes, laws, regulations and ordinances when installing this water heater and related components near high heat sources.

## **NOTICE**

This appliance provides an overheat shutdown limit. In the event the appliance water temperature exceeds the setpoint of the control limit, the cutoff will trip and the appliance will shut down. Certain local codes require additional temperature limits. In addition, certain types of systems may operate at temperatures below the minimum setpoint of the limit provided with the appliance. Contact the manufacturer for additional overheat controls.

### **B. Improper Combustion**

## **WARNING**

Do not obstruct the flow of combustion and ventilating air. Adequate air is necessary for safe operation. Failure to keep the exhaust vent and combustion air intake clear of ice, snow, or other debris could result in property damage, serious personal injury, or death.

### **C. Gas**

Should overheating or gas supply fail to shut off, turn off the manual gas control valve to the water heater.

### **D. When Servicing the Water Heating System**

## **WARNING**

Be sure to disconnect electrical power before opening water heater cabinet or performing service. Label all wires while performing service to ensure proper re-wiring of the water heater. Wiring errors can cause improper or dangerous operation. Failure to do so could result in an electrical shock, improper water heater operation, property damage, serious personal injury, or death.

- To avoid electric shock, disconnect electrical supply before performing maintenance.
- To avoid severe burns, allow water heater and associated equipment to cool before servicing.
- Do not use petroleum-based cleaning or sealing compounds in a water heating system. Gaskets and seals in the system may be damaged. This can result in substantial property damage.

- Do not use "homemade cures" or "patent medicines". Damage to the water heater, substantial property damage, and/or serious personal injury may result.
- Always verify proper operation after servicing the water heater.

**NOTE:** When inquiring about service or troubleshooting, reference the model and serial numbers from the water heater rating label.

### **E. Water Chemistry Requirements**

## **CAUTION**

Chemical imbalance of the water supply may affect efficiency and cause severe damage to the water heater and associated equipment. Water quality must be professionally analyzed to determine whether it is necessary to treat the water. Various solutions are available to adjust water quality. Adverse water quality will affect the reliability of the system. In addition, operating temperatures above 135°F will accelerate the build-up of lime scale and possibly shorten water heater service life. Failure of an water heater due to lime scale build-up, low pH, or other chemical imbalance IS NOT covered by the warranty.

The water must be potable, free of corrosive chemicals, sand, dirt, and other contaminants. It is up to the installer to ensure the water does not contain corrosive chemicals or elements that can damage the heat exchanger. Potable water is defined as drinkable water supplied from utility or well water in compliance with EPA secondary maximum contaminant levels (40 CFR Part 143.3). If the water contains contaminants higher than outlined by the EPA, water treatment is recommended and additional, more frequent maintenance may be required.

If you suspect that your water is contaminated in any way, discontinue use of the water heater and contact an authorized technician or licensed professional.

- **Water pH between 6.5 and 8.5**
  - pH levels below 6.5 can cause an increase in the rate of corrosion. pH of 8.5 or higher can potentially cause lime scale build-up
  - Maintain water pH between 6.5 and 8.5. Check with litmus paper or have it chemically analyzed by a local water treatment company.
  - If the pH is not between 6.5 and 8.5, consult a local water treatment company for solutions.
- **Hardness less than 12 grains (200 mg/L) (Residential Use - water temperatures below 140°F)**
- **Hardness less than 7 grains (120 mg/L) (Commercial Use - water temperatures of 140°F and greater)**
  - Hardness levels above the required amounts can lead to lime scale build-up throughout the system. Water below 5 grains/gallon (85 mg/L) may be over softened.
  - Consult local water treatment companies for unusually hard water areas (above the required amounts) or for other treatment solutions if water is being over softened (below 5 grains/gallon [85 mg/L]).
- **Chloride concentration less than 100 ppm (mg/L)**
  - Do not fill water heater or operate with water containing chlorides in excess of 100 ppm (mg/L).
  - Using chlorinated fresh water should be acceptable as levels are typically less than 5 ppm (mg/L).
  - Do not connect the water heater to directly heat swimming pool or spa water.

- **Total Dissolved Solids (TDS) less than 500 ppm (mg/L)**
- Total dissolved solids are minerals, salts, metals, and charged particles that are dissolved in water.
- The greater the amounts of TDS present, the higher the corrosion potential due to increased conductivity in the water.
- If using softened water to fill the water heater, it is still possible to have high TDS. This water can be corrosive. Consult local water treatment companies for other treatment solutions to reduce this effect.

**\*NOTE:** To promote water heater service life, it is strongly recommended to follow the maintenance procedures in this manual.

**F. Freeze Protection**

**NOTE:** Consider piping and installation when determining heater location.

**CAUTION**

Failure of the water heater due to freeze related damage IS NOT covered by product warranty.

**WARNING**

NEVER use any toxic chemical, including automotive, standard glycol antifreeze, or ethylene glycol made for hydronic (non-potable) systems. These chemicals can attack gaskets and seals in water systems, are poisonous if consumed, and can cause personal injury or death.

**NOTE:** HTP DOES NOT WARRANT THE APPLIANCE AGAINST FREEZE-RELATED DAMAGE.

**G. Water Temperature Adjustment**

This water heater can deliver scalding water. Be careful whenever using hot water to avoid scalding injury. Certain appliances such as dishwashers and automatic clothes washers may require increased water temperatures. By setting the thermostat on this heater to obtain the increased water temperature required by these appliances you may create the potential for scald injury.

To protect against injury, install a mixing valve in the water system. This valve will reduce point of use discharge temperatures by mixing cold and hot water in branch supply lines. Such valves are available from your local plumbing supplier.

Table 1 details the relationship of water temperature and time with regard to scald injury and may be used as a guide in determining the safest water temperature for your applications.

**WARNING**

Households with small children, disabled, or elderly persons may require a 120°F or lower temperature setting to prevent severe personal injury or death due to scalding.

Approximate Time / Temperature Relationships in Scalds	
120°F	More than 5 minutes
125°F	1 1/2 to 2 minutes
130°F	About 30 seconds
135°F	About 10 seconds
140°F	Less than 5 seconds
145°F	Less than 3 seconds
150°F	About 1 1/2 seconds
155°F	About 1 second

**Table 1 - Approximate Time / Temperature Relationships in Scalds**

**WARNING**

An ASSE 1017 or ASSE 1070 temperature limiting or mixing valve is recommended in installations servicing disabled or elderly persons, or children. Mixing valves do not eliminate the risk of scalding.

To avoid scalding:

- Set the water heater set point temperature as low as possible.
- Feel water before bathing or showering.
- If thermostatic valves are required, use devices specifically designed for such purpose. Install these devices in accordance with instructions provided by the manufacturer.

Failure to install a temperature limiting or mixing valve and follow these instructions could result in property damage, severe personal injury, or death due to scalds.

Households with small children, disabled, or elderly persons may require a 120°F or lower temperature setting to prevent severe personal injury or death due to scalding.

**H. High Elevation Installations**

This water heater is designed to operate at its maximum listed capacity in installations located at 0 - 2000 ft above Sea Level. Since the density of air decreases as elevation increases, maximum specified capacity should be de-rated for elevations above 2000 ft (610 m) in accordance with the table below.

Elevations	2001 ft (610 m)	3000 ft (914 m)	4000 ft (1219 m)	4500 ft (1372 m)	5000 ft (1524 m)
<b>In Canada<sup>1</sup>, de-rate by:</b>	10%	10%	10%	10%	may vary
<b>In USA<sup>2</sup>, de-rate by:</b>	-	12%	16%	18%	20%

**NOTES:**

<sup>1</sup>Canada: Elevations between 2000 - 4500 ft (610 - 1372 m), de-rate by 10%. Consult local authorities for de-rating for elevations above 4500 ft (1372 m).  
<sup>2</sup>USA: If elevation is above 2000 ft (610 m), de-rate capacity by 4% for every 1000 ft (305 m).

**Table 2 - De-Rate % for High Elevations**

**WARNING**

Combustion - At elevations above 2000 ft, the combustion of the water heater must be checked with a calibrated combustion analyzer to ensure safe and reliable operation. **It is the Installer's responsibility to check and adjust the combustion in accordance with this manual.** Failure to follow these instructions may result in property damage, serious personal injury, or death.

## Part 2 - Before You Start

Remove the water heater from the packaging. Take care to place the water heater and accessories in a safe location prior to installation to prevent damage to the mechanical connections.

### NOTICE

**UNCRATING THE WATER HEATER** - Any claims for damage or shortage in shipment must be filed immediately against the transportation company by the consignee.

Remove all sides of the shipping crate of the water heater.

#### A. What's in the Box

Components included with the water heater:

- Intake PVC Tee with Screens
- Exhaust PVC Coupling with Screens
- Temperature and Pressure Relief Valve
- Two (2) Brass Piping Adapters
- Two (2) Threaded Brass Caps (PHM Models Only)
- LP Conversion Kit (NG Models Only)
- Installation Manual and Warranty
- User's Information Manual

#### B. How the Heater Operates

**Modulating Condensing Technology** is an intelligent system that delivers highly efficient water heating, maximizing efficiency by measuring the data parameters of your water heating system. Some of its features are:

##### Stainless Steel Water Storage Tank

The stainless steel water storage tank has a combustion chamber submerged into the tank water. When the water heater is fired, combustion gases heat the combustion chamber walls, transferring heat directly into the surrounding water. These hot gases are blown into secondary heat exchanger coils, where more heat from these gases is transferred into the water.

##### Modulating Combustion System

The control monitors the water heating system and temperatures, regulating burner output during operation to match system demand. This increase in efficiency allows for substantial fuel savings.

##### Gas Valve

The gas valve senses suction from the blower, allowing gas to flow only if the gas valve is energized and combustion air is flowing.

##### Upper Outlet Tank Sensor

This sensor monitors the upper portion water temperature (outlet) of the water heater. The control module adjusts burner firing rate so the outlet water temperature meets the set point.

##### Lower Inlet Tank Sensor

This sensor monitors the lower portion water temperature (inlet) of the water heater. The control module reduces or increases input, depending on how close the inlet water temperature is to the outlet water temperature set point.

##### Control

The integrated control system monitors upper and lower water temperature and adjusts fan speed to regulate the heater's energy output. This allows the unit to deliver the required amount of heated energy and nothing more.

##### Burner

Constructed of high grade stainless steel, the burner uses pre-mixed air and gas and provides a wide range of firing rates.

##### Condensate Drain System

This is a condensing high efficiency water heater with a condensate removal system. Condensate is nothing more than water vapor derived from combustion products, similar to that of an automobile when it is initially started. It is very important that the condensate line slopes away from the water heater and down to a suitable inside drain.

If the condensate outlet on the heater is lower than the drain, use a condensate removal pump (Part # 554200, available from HTP). In addition, local authorities may require an additional condensate neutralizer to neutralize the condensate. Condensate neutralizers are made up of lime crystals, marble, or phosphate chips. Neutralizers can be installed in the field by the installer and purchased from HTP (p/n 7450P-212).

It is also very important not to expose the condensate line to freezing temperatures or any type of blockage. Plastic tubing must be the only material used for the condensate line. Steel, brass, copper, or other materials will be subject to corrosion or deterioration. A second vent may be necessary to prevent condensate line vacuum lock on a long horizontal run. Also, an increase in pipe size may be necessary to allow condensate to drain properly. Support of the condensate line may be necessary to avoid blockage of the condensate flow.

##### Spark Ignition

The burner flame is ignited by applying high voltage to the system spark electrode. This causes a spark from electrode to ground.

##### Outdoor Sensor

Monitors outdoor temperature and adjusts set point to provide greater efficiency.

#### C. Optional Equipment

Optional equipment available from HTP (and Part #):

- 3" Stainless Steel Vent Termination Kit (V1000)
- 4" Stainless Steel Vent Termination Kit (V2000)
- 2" PVC Concentric Vent Kit (KGAVT0501CVT)
- 3" PVC Concentric Vent Kit (KGAVT0601CVT)
- 3" Polypro Vent Kit (8400P-001)
- 3" Polypro Pipe  
(33' length # 8400P-002, 49.5' length # 8400P-003)
- Outdoor Sensor (7250P-319)
- PC Connection Kit (7250P-320)
- Condensate Neutralizer (7450P-212)
- Sanitizer Booster Kit (VSBK-1200)
- MODBUS / BACnet Adapter (7350P-636)
- 4" IPEX PVC Common Venting Backflow Valve (7100P-340)
- Common Vent Condensate Assembly (7100P-341)

## Part 3 - Prepare the Water Heater

### CAUTION

**COLD WEATHER HANDLING** - If the water heater has been stored in a very cold location (BELOW 0°F) before installation, handle with care until the components come to room temperature. Failure to do so could result in damage to the water heater.

Carefully consider installation when determining heater location. Please read the entire manual before attempting installation. Failure to properly take factors such as heater venting, piping, condensate removal, and wiring into account before installation could result in wasted time, money, and possible property damage and personal injury.

#### A. Locating the Water Heater

### WARNING

This water heater is certified for indoor use only. DO NOT INSTALL OUTDOORS. Outdoor installations ARE NOT covered by warranty. Failure to install the water heater indoors could result in property damage, severe personal injury, or death.

This water heater must be installed upright in the vertical position as described in this manual. DO NOT attempt to install this water heater in any other orientation. Doing so will result in improper water heater operation and property damage, and could result in serious personal injury or death.

**WARNING**

Incorrect ambient conditions can lead to damage to the heating system and put safe operation at risk. Ensure that the installation location adheres to the information included in this manual. Failure to do so could result in property damage, serious personal injury, or death. Failure of heater or components due to incorrect operating conditions IS NOT covered by product warranty.

This water heater is heavy. Take precautions when moving the water heater into its installation location to avoid tipping, bumping, or dropping it. Failure to take such precautions may result in property damage, severe personal injury, or death.

This water heater has a condensate disposal system that may freeze if exposed to sustained temperatures below 32°F. Precautions should be taken to protect the condensate trap and drain lines from sustained freezing conditions. Failure to take precautions could result in property damage, severe personal injury, or death.

1. Installation Area (Mechanical Room) Operating Conditions

- Ensure ambient temperatures are higher than 32°F / 0°C and lower than 104°F / 40°C
- Prevent the air from becoming contaminated by the products, places, and conditions listed in this manual
- Avoid continuously high levels of humidity
- Never close existing ventilation openings
- Ensure a minimum 1" clearance around hot water and exhaust vent pipes
- NOTE: To prevent condensing in the fan, it is recommended to avoid prolonged exposure to temperatures below 45°F

2. Check for nearby connections to:

- System water piping
- Venting connections
- Gas supply piping
- Electrical power
- Condensate drain

3. Check area around heater. Remove any combustible materials, gasoline, and other flammable liquids.

**WARNING**

Failure to keep the water heater area clear and free of combustible materials, liquids, and vapors can result in substantial property damage, severe personal injury, or death.

Do not connect the water heater to any heating systems or components that have been previously used for non-potable applications.

Do not introduce toxic chemicals, such as antifreeze or water heater treatments, into the water heater or any piping meant for potable water purposes.

Ensure that all piping and components connected to the water heater are suitable for potable water applications.

Do not use this water heater for space heating applications.

Circulators suitable for DHW applications must be used.

Failure to follow these instructions could result in serious personal injury or death.

**CAUTION**

Always take future maintenance into consideration when locating the water heater. If the water heater is located in an installation location with limited clearances, it may be necessary to remove the water heater from the space to perform maintenance. Failure to consider maintenance when determining installation location could result in property damage.

The service life of the water heater's exposed metallic surfaces, such as the casing, as well as internal surfaces, such as the heat exchanger, are directly influenced by proximity to damp and salty marine environments. In such areas higher concentration levels of chlorides from sea spray coupled with relative humidity can lead to degradation of water heater components. In these environments, heaters must not be installed using direct vent systems which draw outdoor air for combustion. Such heaters must be installed using room air for combustion. Indoor air will have a much lower relative humidity, and hence potential corrosion will be minimized.

All water heaters eventually leak. Locate the water heater where any leakage from the relief valve, related piping, tank, or connections will not result in damage to surrounding areas or lower floors of the building. Any water heater should be installed in such a manner that if it should leak the resulting flow of water will not cause damage to the area in which it is installed. National Plumbing codes require a drain pan for any water heater installation. This drain pan should be sized with a maximum depth of 2", and a minimum diameter 2" greater than the diameter of the water heater. The drain pan should empty into an open drain line. This drain line should be 3/4" ID minimum, piped to an open drain. Leakage damages ARE NOT covered by warranty. Failure to install a drain pan is the sole responsibility of the owner and/or installer. Reference UPC 2000 (Uniform Plumbing Code) Section 510 - Protection from Damage or IPC 200 (International Plumbing code) Section 504 - Safety Devices. Leakage damages ARE NOT covered by warranty. In addition, water leak detection devices and automatic water shutoff valves are readily available at plumbing supply houses. IT IS HIGHLY RECOMMENDED BY THE MANUFACTURER TO INSTALL WATER LEAK DETECTION DEVICES AND AUTOMATIC SHUTOFF VALVES IN ANY WATER HEATER INSTALLATION WHERE A LEAKAGE OF WATER COULD RESULT IN PROPERTY DAMAGES.

Failure of the water heater or components due to incorrect operating conditions IS NOT covered by product warranty.

4. Gas control system components must be protected from dripping water during operation and service.

5. If the heater is to replace an existing heater, check for and correct any existing system problems, such as:

- System leaks
- Location that could cause the system and heater to freeze and leak
- Incorrectly sized expansion tank

6. Clean and flush system when reinstalling a heater.

**NOTE:** When installing in a zero clearance location, it may not be possible to read or view some product labeling. It is recommended to make note of the heater model and serial number.

**NOTE:** A combustible door or removable panel is acceptable front clearance.

**B. Leveling**

**CAUTION**

In order for the condensate to properly flow out of the collection system, the area where you locate the heater must be level. Location must also fully support the weight of the filled water heater.

### C. Clearances for Service Access

**WARNING**

The space must be provided with combustion / ventilation air openings correctly sized for all other appliances located in the same space as the heater. The heater cover must be securely fastened to prevent the heater from drawing air from the heater room. This is particularly important if the heater is in a room with other appliances. Failure to comply with the above warnings could result in substantial property damage, severe personal injury, or death.

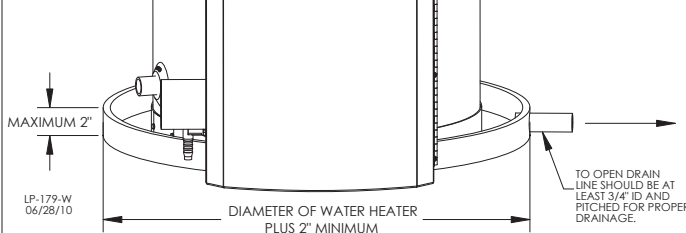
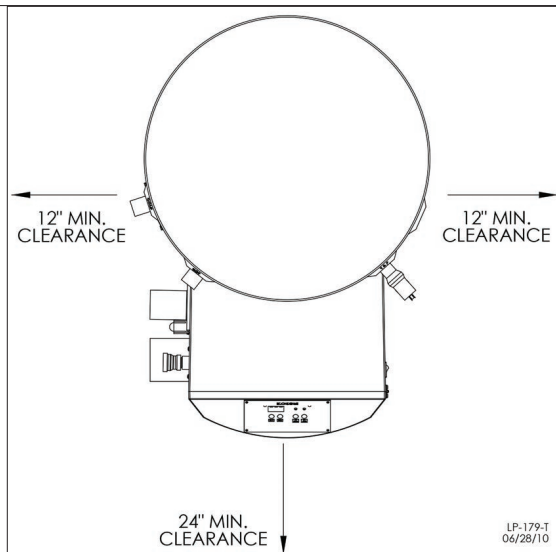
**Figure 1 - Drain Pan Dimensions and Recommended Service Clearances**

**NOTE:** In addition, on PHM models, it is recommended to provide a minimum service clearance of 6" from the top of the water heater to allow for piping of the top ports. Depending on the installation, this clearance may need to be substantially greater than 6".

**NOTE:** If you do not provide the minimum clearances shown in Figure 1 it might not be possible to service the heater without removing it from the space.

**NOTE:** For closet installations, a combustible door or removable panel is acceptable front clearance. A 3" minimum clearance must be provided from the appliance front cover to the removable panel or combustible door.

#### MINIMUM CLEARANCES FROM COMBUSTIBLE MATERIALS

- Hot water pipes - at least 1" from combustible materials
- Exhaust vent pipe - at least 1" from combustible materials

#### Appliance Area Ventilation Air Openings - Closet Installations

If the appliance is installed in a closet or alcove the appliance area/room must be ventilated.

**EXCEPTION:** If the appliance area/room has a volume of 150 ft<sup>3</sup> or greater, ventilation of the appliance area/room is not required.

Each ventilation air opening must meet the minimum requirements of 1 in<sup>2</sup> per 1000 BTU/hr., but not less than 100 in<sup>2</sup>. The lower ventilation opening must be located within 6 in. of the floor, while the upper opening must be located 6 in. from the top of the space.

**WARNING**

If the appliance area has a volume less than 150 ft<sup>3</sup>, it is considered a Closet or Alcove. In the US/Canada, PVC vent pipe and fittings **SHALL NOT BE USED** within the closet or alcove. Only approved CPVC, Polypropylene, or Stainless Steel vent pipe and fittings may be used. See Table 6 for a list of approved materials. Under all circumstances proper ventilation must be provided.

The space must be provided with correctly sized combustion/ventilation air openings for all other appliances located in the space with the appliance. For power venting installations using room air for combustion, refer to the appliance venting section, this manual, for descriptions of confined and unconfined spaces. Do not install the appliance in an attic. The appliance cover must be securely fastened to prevent the appliance from drawing air from the appliance room. This is particularly important if the appliance is in a room with other appliances. Failure to comply with the above warnings could result in substantial property damage, severe personal injury, or death.

#### Alcove Installations

Alcove installations have the same minimum dimensions as closet installations, except the installation must be completely open to the room at a distance no greater than 18 in. (457 mm) from the front of the appliance and the room must be at least three (3) times the size of the alcove. Provided these conditions are met, the appliance requires no extra ventilation air openings to the space. If these conditions are not met, follow the requirements for Closet Installations.

### D. Residential Garage and Closet Installations

**CAUTION**

Check with your local Authority Having Jurisdiction for requirements when installing the water heater in a garage or closet. Please read the entire manual before attempting installation. Failure to properly take factors such as venting, piping, condensate removal, and wiring into account before installation could result in wasted time, money, and possible property damage and personal injury.

#### Precautions

If the heater is located in a residential garage, per ANSI Z223.1:

- Install the water heater burner and ignition devices a minimum of 18" above the floor of the garage. This will ensure the burner and ignition devices are well off the floor.
- When raising the water heater ensure the entire bottom and fully filled weight of the water heater are fully supported.
- Locate or protect the water heater so it cannot be damaged

#### E. Exhaust Vent and Intake Pipe

The heater is rated ANSI Z21.10.3 Category IV (pressurized vent, likely to form condensate in the vent) and requires a special vent system designed for pressurized venting.

**NOTE: The venting options described here (and further detailed in the Venting section, this manual) are the lone venting options approved for this water heater. Failure to vent the water heater in accordance with the provided venting instructions will void the warranty.**

**DANGER**

Failure to vent the water heater properly will result in serious personal injury or death.

**WARNING**

Do not attempt to vent this water heater by any means other than those described in this manual. Doing so will void the warranty and may result in severe personal injury or death.

**WARNING**

Vents must be properly supported. Heater exhaust and intake connections are not designed to carry heavy weight. Vent support brackets must be within 1' of the heater and the balance at 4' intervals. Heater must be readily accessible for visual inspection for first 3' from the water heater. Failure to properly support vents could result in property damage, severe personal injury, or death.

The exhaust discharged by this water heater may be very hot. Avoid touching or other direct contact with the exhaust gases of the vent termination assembly. Doing so could result in severe personal injury or death.

**1. Direct Vent of Exhaust and Intake**

If installing a direct vent option, combustion air must be drawn from the outdoors directly into the water heater intake and exhaust must terminate outdoors. There are three basic direct vent options detailed in this manual: 1. Side Wall Venting, 2. Roof Venting, and 3. Unbalanced Venting.

Be sure to locate the heater such that the exhaust vent and intake piping can be routed through the building and properly terminated. Different vent terminals can be used to simplify and eliminate multiple penetrations in the building structure (see Optional Equipment in Venting Section). The exhaust vent and intake piping lengths, routing, and termination methods must all comply with the methods and limits given in the Venting Section, this manual.

When installing a combustion air intake from outdoors, care must be taken to utilize uncontaminated combustion air. **To prevent combustion air contamination, see Table 3.**

**2. Power Venting, Indoor Combustion Air in Confined or Unconfined Space**

This heater requires fresh, uncontaminated air for safe operation and must be installed in a mechanical room where there is adequate combustion and ventilating air. **NOTE: To prevent combustion air contamination, see Table 3.**

Combustion air from the indoor space can be used if the space has adequate area or when air is provided through a duct or louver to supply sufficient combustion air based on the water heater input. Never obstruct the supply of combustion air to the water heater. If the water heater is installed in areas where indoor air is contaminated (see Table 3) it is imperative that the water heater be installed as direct vent so that all combustion air is taken directly from the outdoors into the water heater intake connection.

**Unconfined space** is space with volume greater than 50 cubic feet per 1,000 BTU/hr (4.8 cubic meters per kW) of the total input rating of all fuel-burning appliances installed in that space. Rooms connected directly to this space through openings not furnished with doors are considered part of the space. See Venting Section for details.

**Confined space** is space with volume less than 50 cubic feet per 1,000 BTU/hr (4.8 cubic meters per kW) of the total input rating of all fuel-burning appliances installed in that space. Rooms connected directly to this space through openings not furnished with doors are considered part of the space.

When drawing combustion air from inside a conventionally constructed building to a confined space, such space should be provided with two permanent openings: one located 6" (15 cm) below the space ceiling, the other 6" (15cm) above the space floor. Each opening should have a free area of one square inch per 1,000 BTU/hr (22cm<sup>2</sup>/kW) of the total input of all appliances in the space, but not less than 100 square inches (645cm<sup>2</sup>).

If the confined space is within a building of tight construction, air for combustion must be obtained from the outdoors as outlined in the Venting section of this manual.

**CAUTION**

When drawing combustion air from the outside into the mechanical room, care must be taken to provide adequate freeze protection.

**WARNING**

Failure to provide an adequate supply of fresh combustion air can cause poisonous flue gases to enter the living space, resulting in severe personal injury or death. To prevent combustion air contamination, see Table 3.

**F. Carbon Monoxide Detectors In the Commonwealth of Massachusetts and As Required by State and Local Codes:**

Installation of Carbon Monoxide Detectors: At the time of installation or replacement of the vented gas fueled appliance, the installing plumber or gas fitter shall observe that a hard wired carbon monoxide detector with an alarm and battery back-up is installed on the floor level where the gas appliance is installed, unless the appliance is located in a detached, uninhabitable structure separate from the dwelling, building, or structure used in whole or in part for residential purposes.

In addition, the installing plumber or gas fitter shall observe that a hard wired carbon monoxide detector with an alarm and battery back-up is installed on each additional level of the dwelling, building, or structure served by the vented gas appliance. It shall be the responsibility of the property owner to secure the service of qualified licensed professionals for the installation of hard wired carbon monoxide detectors.

- a. In the event that the vented gas fueled appliance is installed in a crawl space or attic, the hard wired carbon monoxide detector with alarm and battery back-up shall be installed on the next adjacent floor level.
- b. In the event that these requirements cannot be met at the time of completion of installation, the owner shall have a period of thirty (30) days to comply with the above requirements; provided, however, that during said thirty (30) day period, a battery operated carbon monoxide detector with an alarm shall be installed.

**WARNING**

Do not attempt to vent this water heater by any means other than those described in this manual. Doing so will void the warranty and may result in severe personal injury or death.

Approved Carbon Monoxide Detectors: Each carbon monoxide detector as required in accordance with the above provisions shall comply with NFPA 70 and be ANSI/UL 2034 listed and IAS certified.

**G. Prevent Combustion Air Contamination**

Install intake air piping for the heater as described in the Venting Section, this manual. Do not terminate exhaust in locations that can allow contamination of intake air.

**WARNING**

Ensure that the intake air will not contain any of the contaminants in Table 3. Contaminated air will damage the heater, resulting in possible substantial property damage, severe personal injury, or death. For example, do not pipe intake air near a swimming pool or laundry facilities. These areas always contain contaminants.

Products to Avoid	Areas Likely to Have Contaminants
Spray cans containing fluorocarbons	Dry cleaning / laundry areas and establishments
Permanent wave solutions	Swimming pools
Chlorinated waxes / cleaners	Metal fabrication plants
Chlorine-based swimming pool chemicals	Beauty shops
Calcium chloride used for thawing	Refrigeration repair shops
Sodium chloride used for water softening	Photo processing plants
Refrigerant leaks	Auto body shops
Paint or varnish removers	Plastic manufacturing plants
Hydrochloric or Muriatic acid	Furniture refinishing areas and establishments
Cements and glues	New building construction
Antistatic fabric softeners used in clothes dryers	Remodeling areas
Chlorine-type bleaches, laundry detergents, and cleaning solvents	Garages and workshops
Adhesives used to fasten building products	

Table 3 - Products and Areas Likely to Have Contaminants

**NOTE: DAMAGE TO THE HEATER CAUSED BY EXPOSURE TO CORROSIVE VAPORS IS NOT COVERED BY WARRANTY.** (Refer to the limited warranty for complete terms and conditions.)

**H. Removing a Heater from a Common Vent System**

**⚠ DANGER**

Do not install the heater into a common vent with any other appliance. This will cause flue gas spillage or appliance malfunction, resulting in possible substantial property damage, severe personal injury, or death.

**⚠ WARNING**

Failure to follow all instructions can result in flue gas spillage and carbon monoxide emissions, causing severe personal injury or death.

- When removing an existing heater, follow the steps below.
1. Seal any unused openings in the common venting system.
  2. Visually inspect the venting system for proper size and horizontal pitch to determine if there is blockage, leakage, corrosion, or other deficiencies that could cause an unsafe condition.
  3. If practical, close all building doors, windows, and doors between the space in which the water heater remains connected to the common venting system and other spaces in the building. Turn on clothes dryers and any appliances not connected to the common venting system. Turn on any exhaust fans, such as range hoods and bathroom exhausts, at maximum speed. Do not operate a summer exhaust fan. Close all fireplace dampers.
  4. Place in operation the appliance being inspected. Follow the lighting instructions. Adjust the thermostat so the appliance will operate continuously.
  5. Test for spillage at the draft hood relief opening after 5 minutes of main burner operation. Use the flame of a match or candle or smoke from a cigarette.
  6. After it has been determined that each appliance remaining connected to the common venting system properly vents when tested as outlined, return doors, windows, exhaust fans, fireplace dampers, and any other gas burning appliances to their previous condition of use.

7. Any improper operation of the common venting system should be corrected to conform to the National Fuel Gas Code, ANSI Z223.1. When resizing any portion of the common venting system, the system should approach the minimum size as determined using the appropriate tables in Appendix G of ANSI Z223.1.

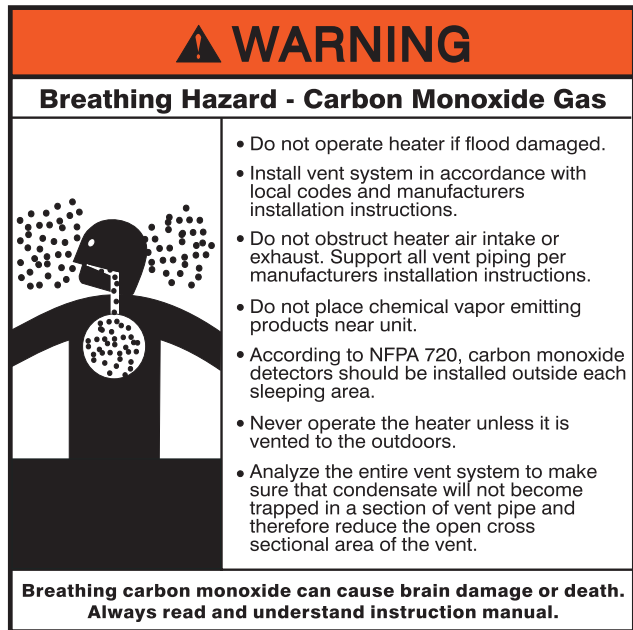

Figure 2 - CO Warning Label

LP-304

**I. Anode Rod**

This water heater may be equipped with an anode rod. Anode rods are sacrificial components that counteract water chemistry to minimize or eliminate tank corrosion. The anode rod should be inspected at least annually and replaced as necessary to prolong tank life. Have the supply water quality professionally analyzed, as local water conditions will influence the duration for inspection and replacement of the anode rod. The use of a water softener may increase the speed of anode consumption. More frequent inspection of the anode is needed when using softened or treated water. Water with high sulfate and/or mineral content can produce a rotten egg odor in heated water. Consult a water treatment specialist for potential remedies.

**NOTE:** Failure of a heat exchanger due to lime scale build-up on the heating surface, low pH, or other imbalance IS NOT covered by the warranty.

**NOTE:** Do not remove the anode rod from an operating water heater. Operating the water heater without the anode rod will shorten the life of the tank and VOID the warranty.

**NOTE:** If anode rods are rapidly consumed water chemistry should be tested by a qualified technician. Corrective action should be taken to prevent the premature failure of the water heating system. Operating the water heater with fully consumed anode rods will shorten the life of the tank and VOID the warranty.

**CAUTION**

Hydrogen gas is produced in a hot water system served by this heater that has not been used for a long period of time (two [2] weeks or more). Hydrogen gas is extremely flammable. To reduce the risk of injury under these conditions, it is recommended that the hot water faucet be opened for several minutes at the kitchen sink before using any electrical appliance connected to the hot water system. When hydrogen is present, there will probably be an unusual sound such as air escaping through the pipe as the water begins to flow. There should be no smoking or open flame near the faucet at the time it is open.

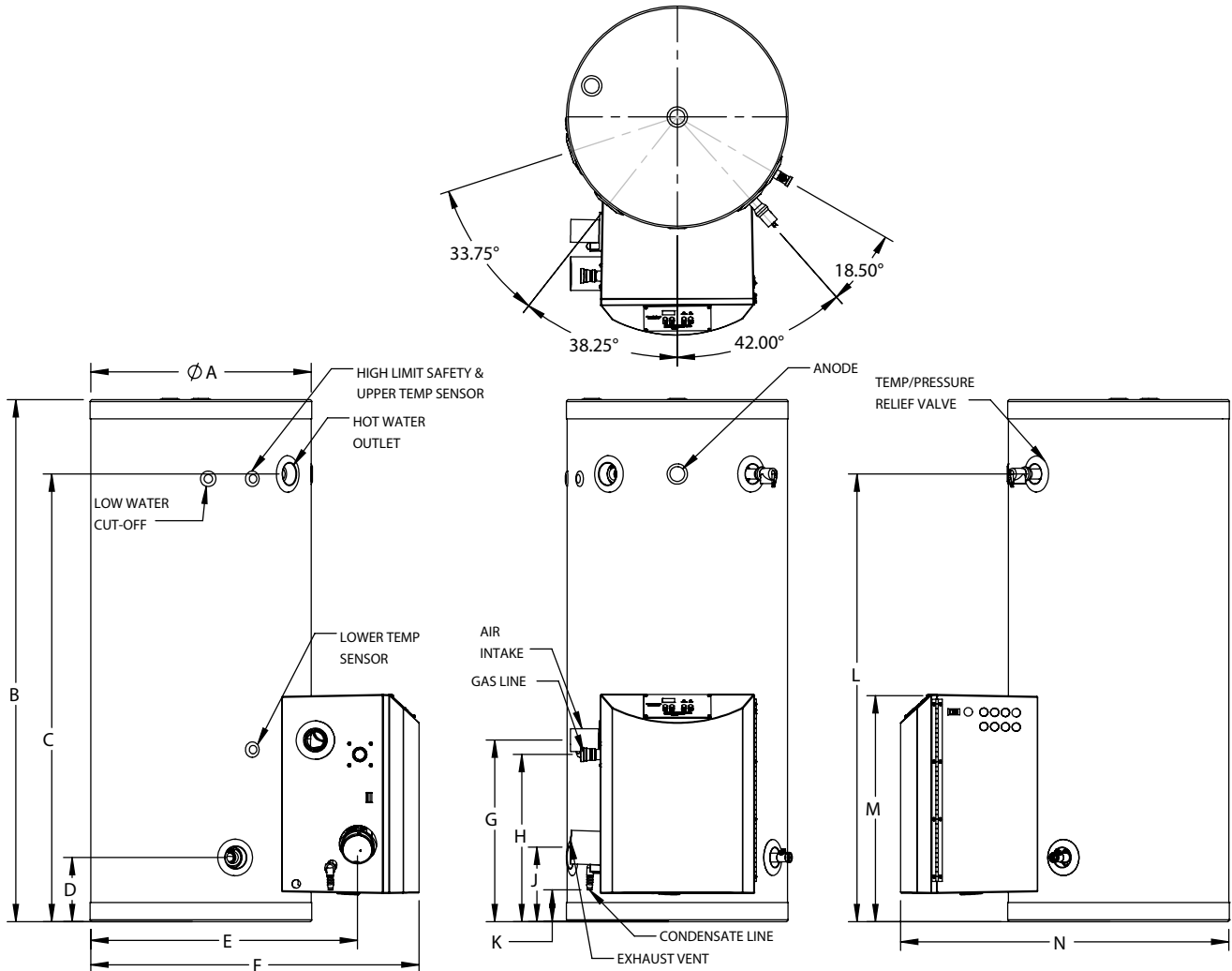

PHOENIX WATER HEATER AND SANITIZER BOOSTER DIMENSIONS														
MODEL*	GAL.	A	B	C	D	E	F	G	H	J	K	L	M	N
PH100-55/130-55/160-55/199-55	55	23"	54-1/4"	46-1/2"	6-1/2"	23-1/4"	27-3/4"	18-1/2"	17"	7-1/2"	3-1/4"	46-1/2"	23-1/4"	34-1/4"
PH100-80/130-80/160-80/199-80	80	23"	74-1/4"	67-3/4"	7-1/4"	27-1/2"	32"	20-3/4"	19-1/4"	10"	5-1/2"	67-3/4"	27"	34-1/4"
PH100-119/130-119/160-119/199-119	119	27"	74"	66-1/4"	7-1/2"	27-1/2"	32"	21-1/2"	18-3/4"	10-1/2"	5"	66-1/2"	24-3/4"	38-1/2"
PH199-55SA	55	23"	54-1/4"	46-1/2"	6-1/2"	23-1/4"	27-3/4"	18-1/2"	17"	7-1/2"	3-1/4"	46-1/2"	23-1/4"	34-1/4"

PHOENIX WATER HEATER SPECIFICATIONS							
MODEL*	INPUT MODULATION	AIR INTAKE/ EXHAUST VENT SIZE	INLET/ OUTLET SIZE	GAS LINE CONN.	SYSTEM RELIEF PIPE SIZE	SHIPPING WEIGHT	MAX. TEMPERATURE LIMIT
PH100-55	30,000 - 100,000	2"	1" NPT	3/4"	3/4"	175 LBS.	160 °
PH130-55	30,000 - 130,000	2"	1" NPT	3/4"	3/4"	175 LBS	160 °
PH160-55	40,000 - 160,000	3"	1" NPT	3/4"	3/4"	175 LBS.	160 °
PH199-55	40,000 - 199,000	3"	1" NPT	3/4"	3/4"	175 LBS	160 °
PH100-80	30,000 - 100,000	2"	1-1/2" NPT	3/4"	3/4"	235 LBS.	160 °
PH130-80	30,000 - 130,000	2"	1-1/2" NPT	3/4"	3/4"	235 LBS	160 °
PH160-80	40,000 - 160,000	3"	1-1/2" NPT	3/4"	3/4"	235 LBS.	160 °
PH199-80	40,000 - 199,000	3"	1-1/2" NPT	3/4"	3/4"	235 LBS.	160 °
PH100-119	30000 - 100,000	2"	1-1/2" NPT	3/4"	3/4"	405 LBS.	160 °
PH130-119	30,000 - 130,000	2"	1-1/2" NPT	3/4"	3/4"	405 LBS.	160 °
PH160-119	40,000 - 160,000	3"	1-1/2" NPT	3/4"	3/4"	405 LBS.	160 °
PH199-119	40,000 - 199,000	3"	1-1/2" NPT	3/4"	3/4"	405 LBS.	160 °
PHOENIX SANITIZER BOOSTER SPECIFICATIONS							
PH-199-55SA	40,000 - 199,000	3"	1"	3/4"	3/4	175 LBS	184 °

\*ALL DIMENSIONS ARE APPROXIMATE, A SUFFIX OF "LP" DENOTES PROPANE GAS

Figure 3 - Water Heater Dimensions - NOTE: All Dimensions Are Approximate

LP-179-B  
08/25/21

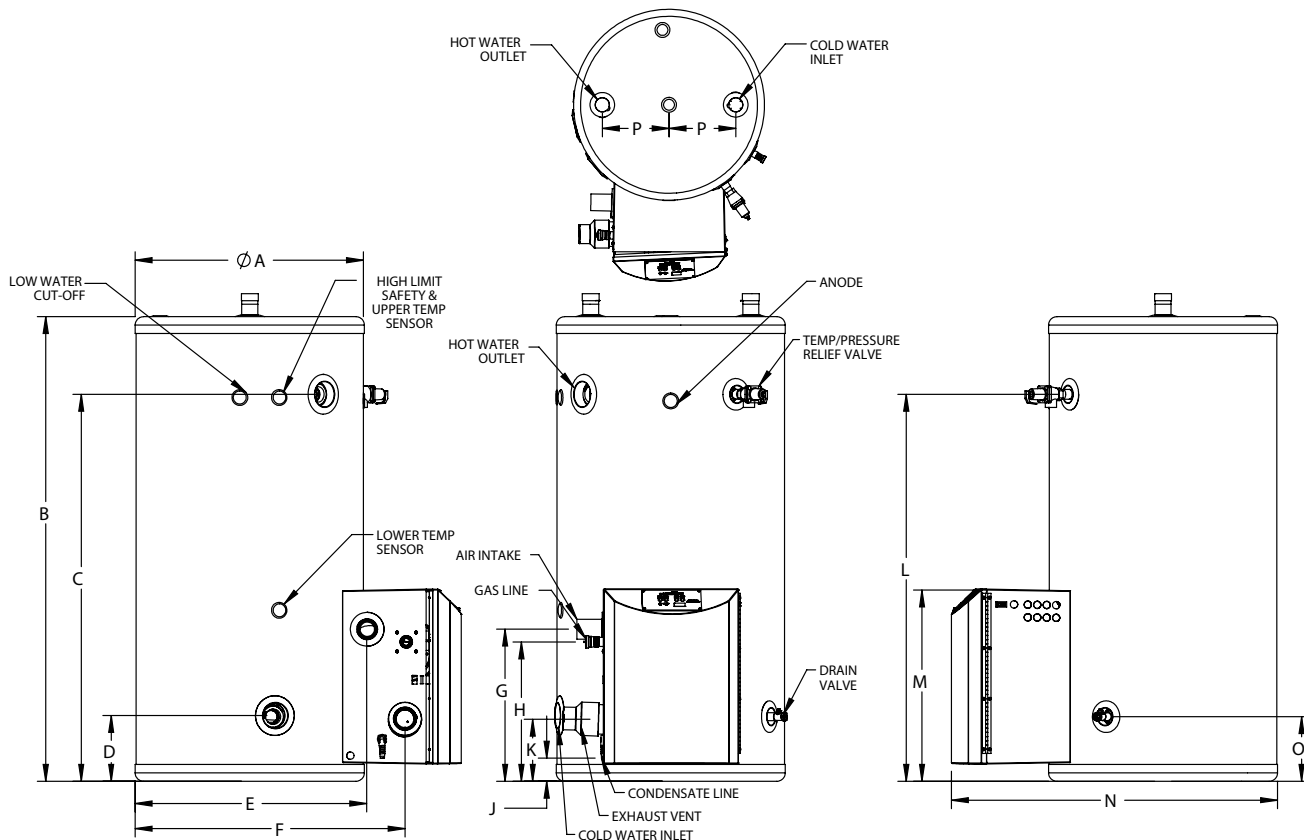

PHOENIX MULTI FIT WATER HEATER																
MODEL*	GAL.	A	B	C	D	E	F	G	H	J	K	L	M	N	O	P
PHM130-80/199-80	80	27"	55"	45-1/4"	7-1/4"	27-1/2"	32"	18-1/4"	17"	3"	8"	45-1/4"	24-3/4"	38-1/4"	7-1/4"	9-1/2"
PHM130-100/199-100	100	27"	63"	54"	7-1/4"	27-1/2"	32"	18-1/4"	17"	3"	8"	54"	24-3/4"	38-1/4"	7-1/4"	9-1/2"

PHOENIX MULTI FIT WATER HEATER SPECIFICATION							
MODEL*	INPUT MODULATION	AIR INTAKE/ EXHAUST VENT SIZE	INLET/ OUTLET SIZE	GAS LINE CONN.	SYSTEM RELIEF PIPE SIZE	SHIPPING WEIGHT	MAX. TEMPERATURE LIMIT
PHM130-80	30,000 - 130,000	2"	1-1/2" NPT	3/4"	3/4"	285 LBS	160 °
PHM199-80	40,000 - 199,000	3"	1-1/2" NPT	3/4"	3/4"	285 LBS.	160 °
PHM130-100	30,000 - 130,000	2"	1-1/2" NPT	3/4"	3/4"	315 LBS.	160 °
PHM199-100	40,000 - 199,000	3"	1-1/2" NPT	3/4"	3/4"	315 LBS.	160 °

LP-179-B  
08/25/21

\*ALL DIMENSIONS ARE APPROXIMATE, A SUFFIX OF "LP" DENOTES PROPANE GAS

Figure 4 - Water Heater Dimensions - NOTE: All Dimensions Are Approximate

Performance Specifications for Phoenix Models													
BTU/Hr	Efficiency	Temperature Rise in Degrees Fahrenheit (F) and Celsius (C)											
		(°F)	40	50	60	70	80	90	100	110	120	130	140
		(°C)	22	28	33	39	44	50	56	61	67	72	78
100,000	96%	<b>GPH</b>	298	240	202	173	152	136	123	110	101	94	88
		<b>LPH</b>	1128	908	765	655	575	515	466	416	382	356	333
130,000		<b>GPH</b>	384	309	260	222	195	175	158	141	130	120	112
		<b>LPH</b>	1454	1170	984	840	738	662	598	534	492	454	424
160,000		<b>GPH</b>	470	378	317	271	238	213	192	173	159	147	137
		<b>LPH</b>	1779	1431	1200	1026	901	806	727	655	602	556	519
199,000		<b>GPH</b>	582	468	392	335	294	263	237	213	196	181	169
		<b>LPH</b>	2203	1772	1484	1268	1113	996	897	806	742	685	640

Table 4 - Recovery on Rating Plate is based at 94% Thermal Efficiency at 70° Fahrenheit rise, as required by ANSI

Performance Equations

$$\text{GPM} = \frac{\text{Rated Input} \times .9}{\text{Temp Rise } (^\circ\text{F}) \times 500} \quad \text{GPH} = \text{GPM} \times 60$$

**Part 4 - Piping**

 <b>WARNING</b>
Failure to follow the instructions in this section WILL VOID the warranty and may result in property damage, severe personal injury, or death.
<b>CAUTION</b>
DO NOT pipe this water heater with black iron, galvanized steel, steel, or lead pipe. Doing so will result in premature product failure and property damage, and WILL VOID the warranty.
Do not apply a torch within 12" of the water heater. If sweat connections are used, sweat tubing to the adapter before fitting adapter to the water connections on the heater. Damages due to improper installation practices ARE NOT covered by warranty.
Dielectric unions or galvanized steel fittings must not be used in a system with this water heater. Doing so WILL VOID the warranty. Use only copper, brass, or stainless steel fittings. Teflon thread sealant must be used on all connections.

Plumbing of this appliance should only be done by a qualified, licensed plumber in accordance with all local plumbing codes.

**A. General Plumbing Information**

<b>CAUTION</b>
Use two wrenches when tightening water piping at heater. Use one wrench to prevent the heater return or supply line from turning. Failure to prevent piping connections from turning could cause damage to heater components.
The heater control module uses temperature sensors to provide both high limit protection and modulating temperature control. Some codes / jurisdictions may require additional external controls.
Pump motors should not be supported by any type of stand due to possible misalignment of pump and motor. Failure to follow this instruction may result in property damage or personal injury.

The domestic water connections must be installed in accordance to all local and national plumbing codes, or any applicable standard which prevails. The inlet (cold) and outlet (hot) ports are 1" on 55 gallon models, and 1 1/2" on 80 and 119 gallon models.

- Pipe material must be suitable to meet local codes and industry standards.
- The pipe must be cleaned and without blemish before any connections are made.
- All water piping should be insulated.

On the cold inlet, install a 1" brass tee on 55 gallon models, or a 1 1/2" tee on 80 and 119 gallon models. On the run of the 1" brass tee, install a 1" brass drain cock or equivalent with pipe sealant compound. In the branch of the 1" or 1 1/2" brass tee, install a copper male adapter to match your copper plumbing system. For convenience, it is recommended to install a sweat shut-off valve and a union in the cold inlet piping and hot outlet to ease future servicing. If there is a backflow preventer or any type of a no return valve in the system, install an additional tee here, suitable for a potable hot water expansion tank.

In the hot outlet, install a suitable adapter to match the copper tubing of the plumbing system. A thermal trap or heat trap loop may be installed here to provide additional energy savings and prevent the thermal siphoning of domestic hot water.

**B. Backflow Preventer**

Use a backflow preventer specifically designed for water heater installations. This valve should be installed on the cold water fill supply line per local codes.

**C. Potable Expansion Tank**

A potable hot water expansion tank is required to offset heated water expansion. In most city plumbing systems, the water meter has a no return or back flow device built into the system to prevent back flowing of water into city mains. Some local codes require back flow preventers on all incoming water supplies. The hot water expansion tank must be listed for potable water use. The expansion tank should be located on the cold inlet piping close to the water heater.

**Expansion Tank and Make-Up Water**

1. Ensure that the expansion tank is sized to correctly handle heater and system water volume and temperature.

 <b>WARNING</b>
Expansion tanks must be sized according to total system volume. This includes all length of pipe, all fixtures, boilers, etc. Failure to properly size for system expansion could result in wasted time, money, possible property damage, serious personal injury, or death.
<b>CAUTION</b>
Undersized expansion tanks cause system water to be lost from the relief valve, causing make-up water to be added. Eventual heater failure can result due to excessive make-up water addition. <b>SUCH FAILURE IS NOT COVERED BY WARRANTY.</b>
The expansion tank must be suitable for hot potable water systems.

2. The expansion tank must be located as shown in Applications, this manual, or following recognized design methods. See expansion tank manufacturer's instructions for details.

**D. Temperature and Pressure Relief Valve**

 <b>WARNING</b>
Overheated water and high pressures can cause water tank explosion. A properly sized temperature and pressure relief valve must be installed in the opening provided on the water heater. Failure to install a properly sized temperature and pressure relief valve could result in explosion and property damage, serious injury, or death.
Do not thread a cap or plug into the relief valve or relief valve line under any circumstances! Explosion and property damage, serious injury, or death may result.

**WARNING**

To avoid water damage or scalding due to relief valve operation:

- Discharge line must be connected to relief valve outlet and run to a safe place of disposal. Terminate the discharge line in a manner that will prevent possibility of severe burns or property damage should the relief valve discharge.
- Discharge line must be as short as possible and the same size as the valve discharge connection throughout its entire length.
- Discharge line must pitch downward from the valve and terminate at least 6" above the floor drain, making discharge clearly visible.
- The discharge line shall terminate plain, not threaded, with a material serviceable for temperatures of 375°F or greater.
- Do not pipe discharge to any location where freezing could occur.
- No valve may be installed between the relief valve and heater or in the discharge line. Do not plug or place any obstruction in the discharge line.
- Test the operation of the relief valve after filling and pressurizing the system by lifting the lever. Make sure the valve discharges freely. If the valve fails to operate correctly, immediately replace with a new properly rated relief valve.
- Test T&P valve at least once annually to ensure the waterway is clear. If valve does not operate, turn the heater "off" and call a plumber immediately.
- Take care whenever operating relief valve to avoid scalding injury or property damage.

FAILURE TO COMPLY WITH THE ABOVE GUIDELINES COULD RESULT IN FAILURE OF RELIEF VALVE OPERATION, RESULTING IN POSSIBILITY OF SUBSTANTIAL PROPERTY DAMAGE, SEVERE PERSONAL INJURY, OR DEATH.

**RE-INSPECTION OF T&P RELIEF VALVES: T&P valves should be inspected AT LEAST ONCE EVERY THREE YEARS, and replaced if necessary,** by a licensed plumbing contractor or qualified service technician to ensure that the product has not been affected by corrosive water conditions and to ensure that the valve and discharge line have not been altered or tampered with illegally. Certain naturally occurring conditions may corrode the valve and its components over time, rendering the valve inoperative. Such conditions can only be detected if the valve and its components are physically removed and inspected. **Do not attempt to conduct an inspection on your own.** Contact your plumbing contractor for a re-inspection to assure continued safety.

**FAILURE TO RE-INSPECT THE T&P VALVE AS DIRECTED COULD RESULT IN UNSAFE TEMPERATURE AND/OR PRESSURE BUILD-UP WHICH CAN RESULT IN PROPERTY DAMAGE, SERIOUS PERSONAL INJURY, OR DEATH.**

**E. Scalding**

**WARNING**

An ASSE 1017 or ASSE 1070 temperature limiting or mixing valve is recommended in installations servicing disabled or elderly persons, or children. Mixing valves do not eliminate the risk of scalding.

To avoid scalding:

- Set the water heater set point temperature as low as possible.
- Feel water before bathing or showering.
- If thermostatic valves are required, use devices specifically designed for such purpose. Install these devices in accordance with instructions provided by the manufacturer.

Failure to install a temperature limiting or mixing valve and follow these instructions could result in property damage, severe personal injury, or death due to scalds.

This water heater can deliver scalding water. Be careful whenever using hot water to avoid scalding injury. Certain appliances such as dishwashers and automatic clothes washers may require increased water temperatures. By setting the thermostat on this heater to obtain the increased water temperature required by these appliances you may create the potential for scald injury.

To protect against injury, install a mixing valve in the water system. This valve will reduce point of use discharge temperatures by mixing cold and hot water in branch supply lines. Such valves are available from your local plumbing supplier.

Table 5 details the relationship of water temperature and time with regard to scald injury and may be used as a guide in determining the safest water temperature for your applications.

**DANGER**



Water temperature over 125°F can cause severe burns instantly or death from scalds. Children, disabled and elderly are at highest risk of being scalded. See instruction manual before setting temperature at water heater. Feel water before bathing or showering. Temperature limiting valves are available, see manual.

**Approximate Time / Temperature Relationships in Scalds**

Approximate Time / Temperature Relationships in Scalds	
120°F	More than 5 minutes
125°F	1 1/2 to 2 minutes
130°F	About 30 seconds
135°F	About 10 seconds
140°F	Less than 5 seconds
145°F	Less than 3 seconds
150°F	About 1 1/2 seconds
155°F	About 1 second

**Table 5 - Approximate Time / Temperature Relationships in Scalds**

**F. Filling the Heater**

**WARNING**

The water heater must be full of water and the system fully purged BEFORE powering the water heater. When filling the water heater, open a hot water tap to release air in the tank and piping. All air has been purged from the system when water runs freely from the faucets.

Applying power to the water heater when it is not full of water will damage the heat exchanger, and could result in property damage, serious personal injury, or death. Such damages ARE NOT covered by water heater warranty.

- Make certain the drain valve is completely closed.
- Open the shut-off valve in the cold water supply line.
- Open the hot water faucets to allow air to vent from the heater and piping.
- Allow sufficient time for the heater to completely fill with water.

## G. Applications

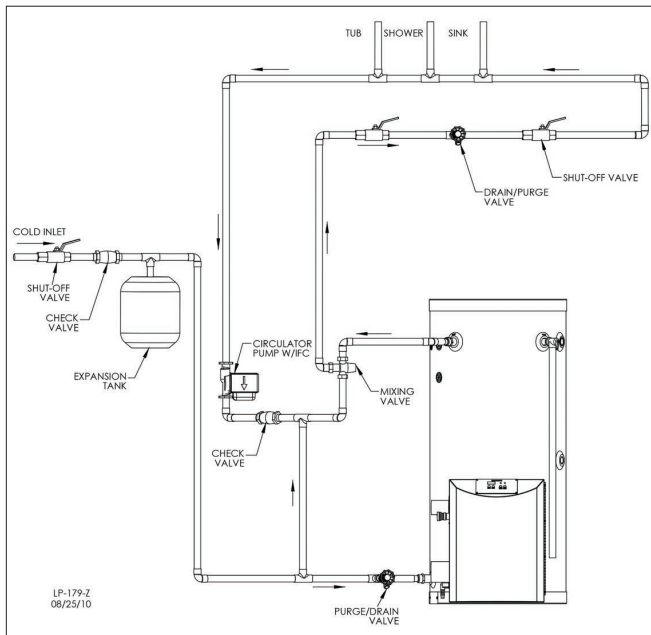

**Figure 5 - Piping with Recirculation Line and Thermostatic Mixing Valve**

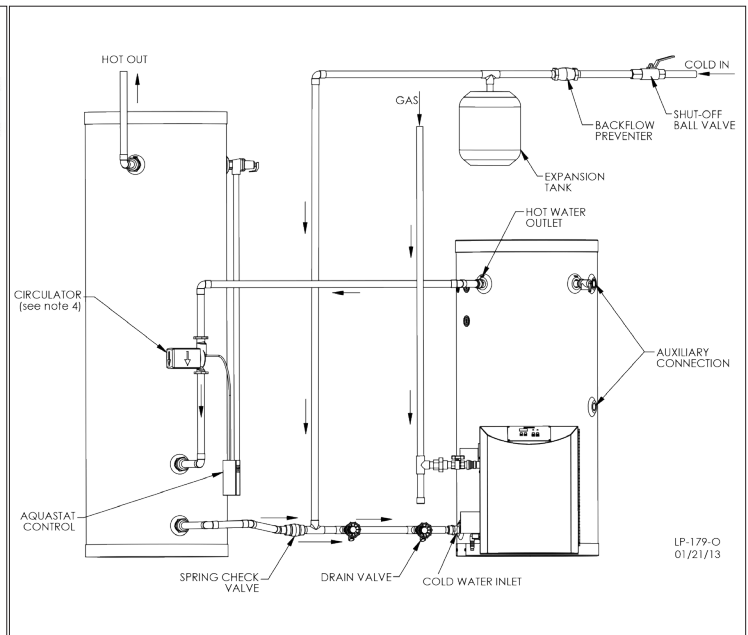

**Figure 6 - Piping with Storage Tank**

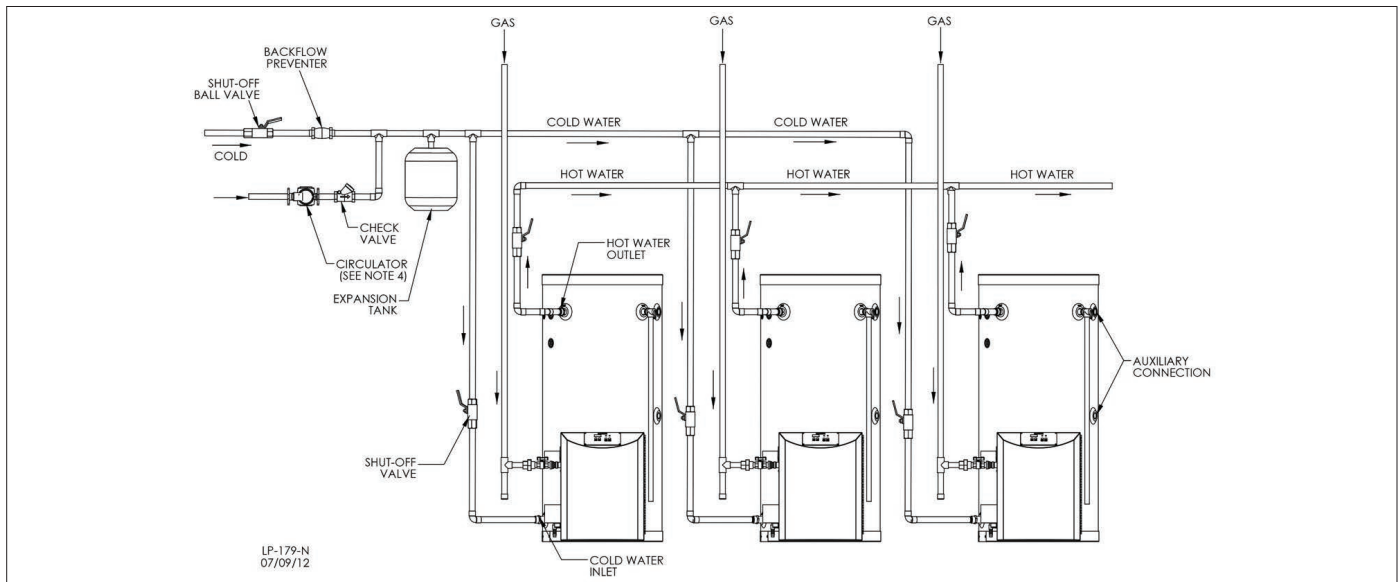

**Figure 7 - Reverse Manifold Piping Diagram for Multiple Water Heaters**

### NOTES:

1. Minimum pipe size should match connection size. Upsize pipe accordingly if greater flow is required.
2. A thermal expansion tank suitable for potable water must be sized and installed within this piping system between the backflow preventer and the cold water inlet.
3. All circulators should have an integral flow check.
4. Drains and check valve between unit and storage tank will assist in purging air from system.
5. These drawings are meant to demonstrate system piping only. The installer is responsible for all equipment and detailing required by local codes. In Massachusetts, you must install a vacuum relief valve per 248 CMR.
6. Mixing valve application is optional, but recommended to help prevent scalding.
7. Always shut off power to the water heater or isolate the heater from the system if ANY plumbing work is to be done. Running the water heater without water will result in dry-firing.

## **WARNING**

An ASSE 1017 thermostatic mixing valve **MUST** be installed when using outdoor reset. Failure to do so could result in substantial property damage, serious injury, or death.

The piping will not support the weight of the water heater circulator pump. Refer to the pump manufacturer's installation instructions to properly support the circulator pump. Failure to comply with these instructions could result in substantial property damage, severe personal injury, or death.

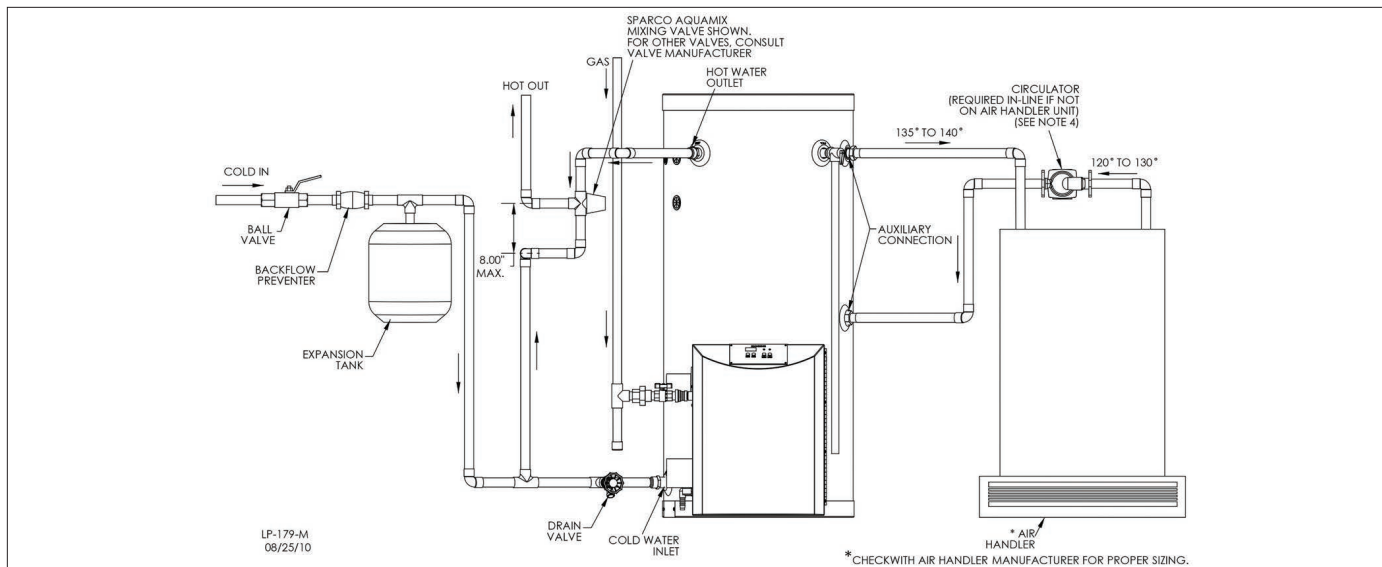

**Figure 8 - Piping with Air Handler on Side**

**NOTES:**

1. Minimum pipe size should match connection size. Upsize pipe accordingly if greater flow is required.
2. A thermal expansion tank suitable for potable water must be sized and installed within this piping system between the backflow preventer and the cold water inlet.
3. All circulators should have an integral flow check.
4. Drains and check valve between unit and storage tank will assist in purging air from system.
5. These drawings are meant to demonstrate system piping only. The installer is responsible for all equipment and detailing required by local codes. In Massachusetts, you must install a vacuum relief valve per 248 CMR.
6. Mixing valve application is optional, but recommended to help prevent scalding.
7. Always shut off power to the water heater or isolate the heater from the system if ANY plumbing work is to be done. Running the water heater without water will result in dry-firing.

**NOTES FOR AIR HANDLER APPLICATION:**

1. MASSACHUSETTS STATE PLUMBING CODE REQUIRES A DISTANCE NO GREATER THAN 50 FEET FROM THE WATER HEATER TO THE FAN COIL IN THE AIR HANDLER.
2. MASSACHUSETTS STATE PLUMBING CODE REQUIRES AN ELECTRONICALLY TIMED CIRCULATOR PUMP TO ACTIVATE EVERY SIX HOURS FOR 60 SECONDS. THIS CIRCULATOR IS REQUIRED TO BE BRONZE OR STAINLESS.
3. ALL WATER PIPING MUST BE INSULATED.
4. YOU MUST INSTALL A VACUUM RELIEF VALVE PER 248 CMR.

**NOTE: THIS DRAWING IS MEANT TO DEMONSTRATE SYSTEM PIPING ONLY. THE INSTALLER IS RESPONSIBLE FOR ALL EQUIPMENT AND DETAILING REQUIRED BY LOCAL CODES.**

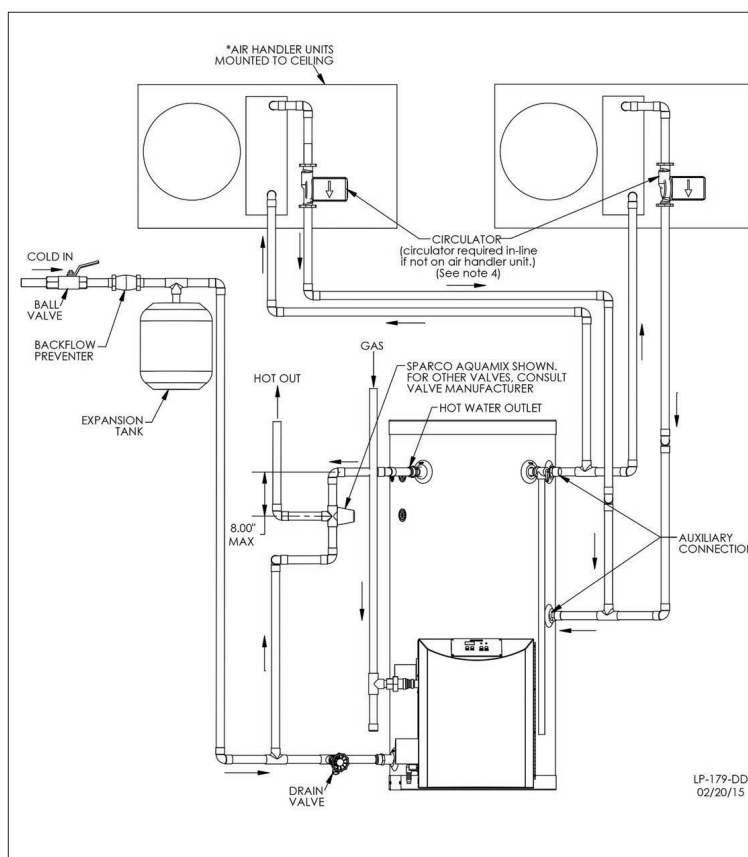

**Figure 9 - Piping with Air Handlers**

**WARNING**

An ASSE 1017 thermostatic mixing valve **MUST** be installed when using outdoor reset. Failure to do so could result in substantial property damage, serious injury, or death.

The piping will not support the weight of the water heater circulator pump. Refer to the pump manufacturer's installation instructions to properly support the circulator pump. Failure to comply with these instructions could result in substantial property damage, severe personal injury, or death.

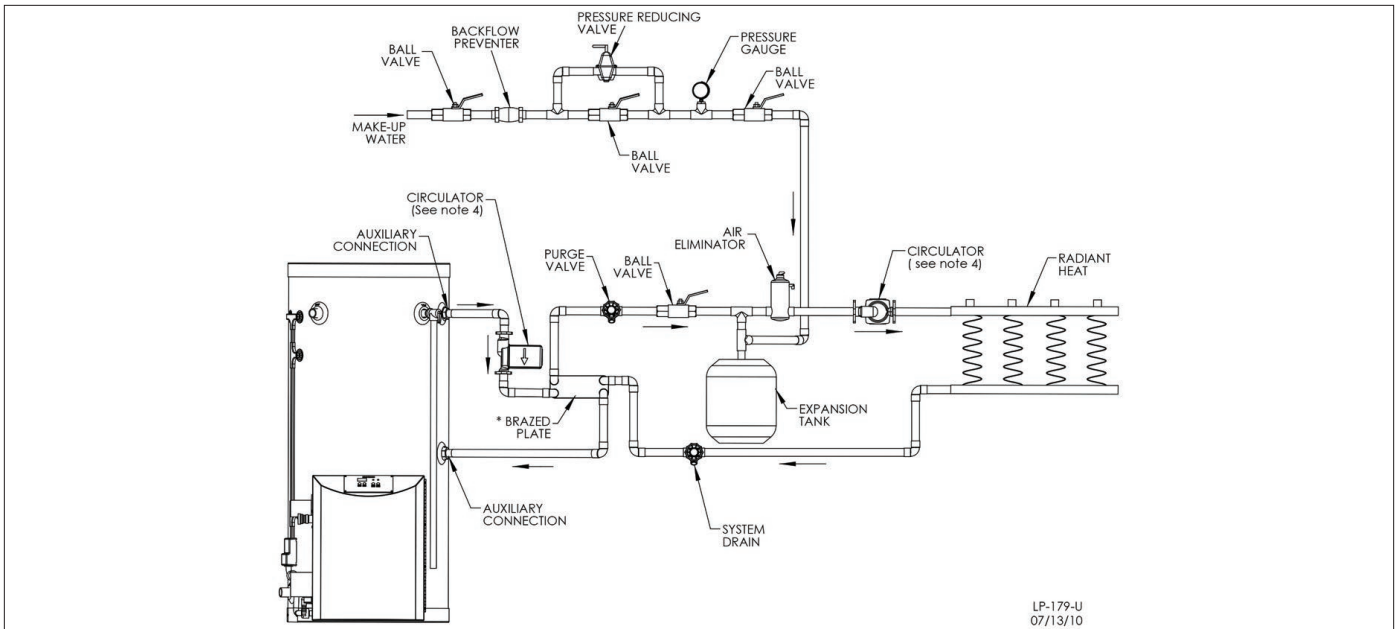

Figure 10 - Piping with Closed Loop for Radiant Heating

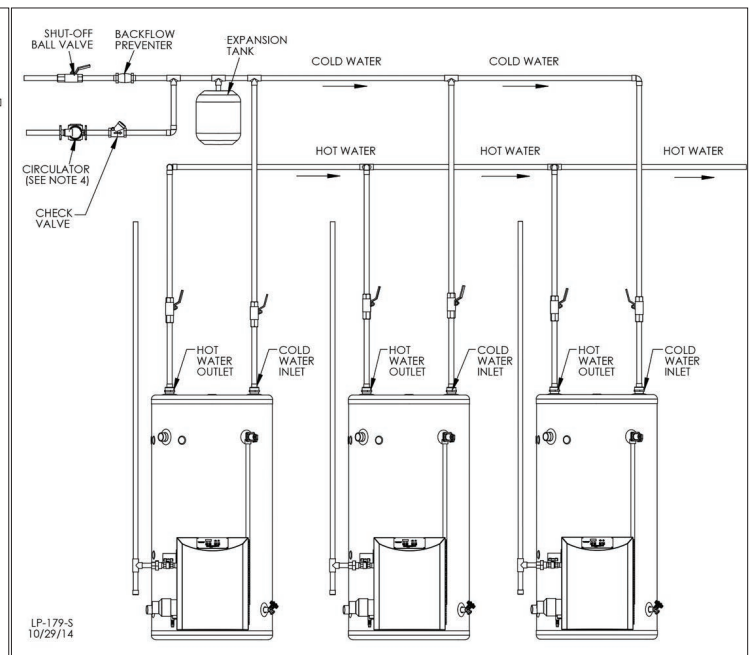
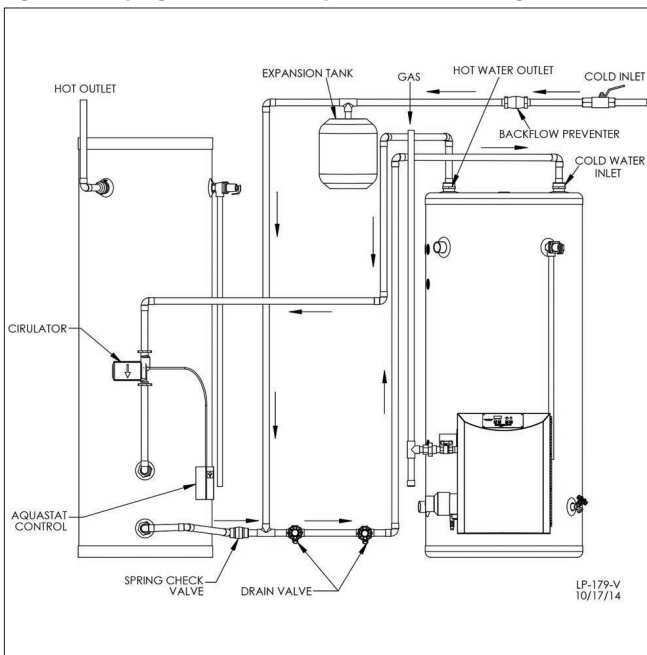

Figure 11 - PHM Model Piping with Storage Tank and Thermostatic Mixing Valve

Figure 12 - Reverse Manifold Piping Diagram for Multiple PHM Models

**NOTES:**

1. Minimum pipe size should match connection size. Upsize pipe accordingly if greater flow is required.
2. A thermal expansion tank suitable for potable water must be sized and installed within this piping system between the backflow preventer and the cold water inlet.
3. All circulators should have an integral flow check.
4. Drains and check valve between unit and storage tank will assist in purging air from system.
5. These drawings are meant to demonstrate system piping only. The installer is responsible for all equipment and detailing required by local codes. In Massachusetts, you must install a vacuum relief valve per 248 CMR.
6. Mixing valve application is optional, but recommended to help prevent scalding.
7. Always shut off power to the water heater or isolate the heater from the system if ANY plumbing work is to be done. Running the water heater without water will result in dry-firing.

**WARNING**

An ASSE 1017 thermostatic mixing valve **MUST** be installed when using outdoor reset. Failure to do so could result in substantial property damage, serious injury, or death.

The piping will not support the weight of the water heater circulator pump. Refer to the pump manufacturer's installation instructions to properly support the circulator pump. Failure to comply with these instructions could result in substantial property damage, severe personal injury, or death.

## NOTICE

The standard unit does not meet the required temperature settings for sanitizer booster applications. Use only the Sanitizer Booster that delivers temperatures of 184°F. Inlet water to the booster must be supplied at 140°F.

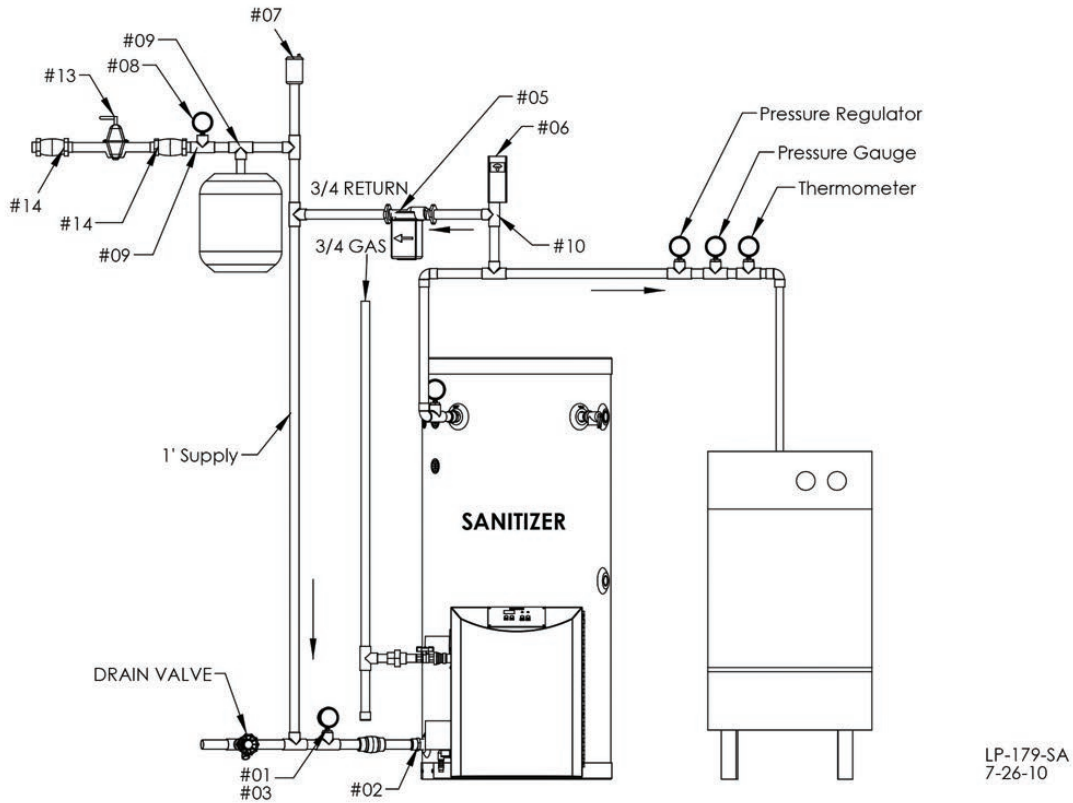

**WARNING; INCOMING SUPPLY MUST BE NO FURTHER THAN 5' FROM THE SANITIZER**  
**VERY IMPORTANT: INSULATE ALL PIPES ON RECIRCULATION LINE TO AND FROM SANITIZER**  
 THE ITEMS LISTED BELOW ARE THE ITEMS AND PART NUMBERS IN THE VSBK-1200 SANITIZER BOOSTER KIT

ITEM	PART	DESCRIPTION	PART NUMBER	ITEM	PART	DESCRIPTION	PART NUMBER
#01	NIBCO TEE	1"X1"X 1/2"	7000-708	#08	PRESSURE GAUGE		7000-716
#02	FEMALE ADAPTER	1"	7000-709	#09	NIBCO TEE	1" X 1" X 3/4" 712R	7000-728
#03	DIAL THERMOMETER		7000-710	#10	NIBCO TEE	1" X 1/2" X 1" COPPER	7000-739
#04	EXPANSION TANK 4.5 GAL		7000-711	#11	NIBCO TEE	1" X 1/2" X 1" R	7000-730
#05	GRUNDFOS 3 SPEED PUMP	W/ CHECK VALVE	7000-712	#12	REDUCING COUPLING		7000-732
#06	NIBCO TEE	1/2" X 1/2" FITTING AIR CHAMBER	7000-737	#13	PRESSURE REDUCING VALVE		7000-733
#07	VACUUM RELIEF VALVE		7000-714	#14	NIBCO MALE ADAPTERS		7000-736

Figure 13 - SA Model Installation

**NOTES:**

1. Minimum pipe size should match connection size. Upsize pipe accordingly if greater flow is required.
2. A thermal expansion tank suitable for potable water must be sized and installed within this piping system between the backflow preventer and the cold water inlet.
3. All circulators should have an integral flow check.
4. Drains and check valve between unit and storage tank will assist in purging air from system.
5. This drawing is meant to demonstrate system piping only. The installer is responsible for all equipment and detailing required by local codes. In Massachusetts, you must install a vacuum relief valve per 248 CMR.
6. Always shut off power to the water heater or isolate the heater from the system if ANY plumbing work is to be done. Running the water heater without water will result in dry-firing.
7. For further energy savings, install the SA Model on the same electrical circuit as the dishwasher.

## ⚠ WARNING

The piping will not support the weight of the water heater circulator pump. Refer to the pump manufacturer's installation instructions to properly support the circulator pump. Failure to comply with these instructions could result in substantial property damage, severe personal injury, or death.

**Part 5 - Venting**

**⚠ DANGER**

The heater must be vented as detailed in this section. Ensure exhaust vent and intake piping complies with these instructions regarding vent system. Inspect finished exhaust vent and intake piping thoroughly to ensure all joints are well secured, airtight, and comply with all applicable code requirements, as well as the instructions provided in this manual. Failure to properly install the vent system will result in severe personal injury or death.

**A. General**

**⚠ DANGER**

This heater is certified as a "Category IV" appliance and requires a special venting system. The vent system will operate with a positive pressure in the pipe. Exhaust gases must be piped directly outdoors using the vent materials and rules outlined in these instructions. Do not connect vent connectors serving appliances vented by natural draft into any portion of mechanical draft systems operating under positive pressure. Follow the venting instructions carefully. Failure to do so will result in substantial property damage, severe personal injury, or death.

Exhaust and intake are to be piped separately. This heater cannot share a common exhaust or intake with multiple appliances without an approved HTP Backflow Valve (7100P-340) and Condensate Assembly (7100P-341). One (1) Backflow Valve must be installed per each heater installed in the common vent system. One (1) Condensate Assembly must be installed in the common vent system. Failure to follow these instructions will result in substantial property damage, severe personal injury, or death.

1. Installation should be made in accordance with the regulations of the Authority Having Jurisdiction, local code authorities, and utility companies which pertain to this type of water heating equipment.
2. Install the venting system in accordance with these instructions and with the National Fuel Gas Code, ANSI Z223.1/NFPA 54, CAN/CGA B149, and / or applicable provisions of local building codes.
3. This water heater must be vented with materials, components, and systems listed and approved for Category IV appliances.

**NOTE:** To avoid contamination often contained in indoor air, it is best to pipe all intake combustion air directly to the outdoors.

**NOTE:** Care must be taken to prevent condensate freezing in the exhaust vent pipe system. See local, state, provincial, and national codes for best practices to prevent condensate freezing in the exhaust vent pipe system.

**⚠ WARNING**

Improper seating of vent pipe gaskets can cause eventual gasket failure and exhaust gas leakage. Ensure the exhaust vent pipe is properly beveled and seated before insertion into the flue adapter. Failure to do so could result in property damage, severe personal injury, or death.

Exhaust vent adaptors are not designed as load-bearing devices, and must not be used to support exhaust vent piping. All vent pipes must be properly connected, supported, and the exhaust vent must be pitched a minimum of 1/4" per foot back to the heater to allow drainage of condensate. Failure to properly support vent piping and follow the information in this statement could result in product damage, severe personal injury, or death.

It is required to insert the provided exhaust and intake screens into the vent terminations to prevent blockage caused by debris or birds. Failure to keep terminations clear could result in property damage, severe personal injury, or death.

**⚠ WARNING**

**Breathing Hazard - Carbon Monoxide Gas**



- Do not operate heater if flood damaged.
- Install vent system in accordance with local codes and manufacturers installation instructions.
- Do not obstruct heater air intake or exhaust. Support all vent piping per manufacturers installation instructions.
- Do not place chemical vapor emitting products near unit.
- According to NFPA 720, carbon monoxide detectors should be installed outside each sleeping area.
- Never operate the heater unless it is vented to the outdoors.
- Analyze the entire vent system to make sure that condensate will not become trapped in a section of vent pipe and therefore reduce the open cross sectional area of the vent.

**Breathing carbon monoxide can cause brain damage or death. Always read and understand instruction manual.**

**⚠ DANGER**

Due to the extreme flammability of most glues, cements, solvents, and primers used to join plastic exhaust vent and intake pipes, explosive solvent vapors must be cleared from all vent piping before start-up. Avoid using excess cement or primer, as this may pool in the vent pipes. Vent assemblies should be allowed to cure for a period of at least 8 hours before powering a connected appliance. Failure to follow these instructions will result in substantial property damage, severe personal injury, or death. It is the installers' responsibility to understand the hazards associated with explosive solvents and take the necessary precautions to avoid these risks.

**⚠ WARNING**

- Only Stainless Steel exhaust vent pipe material may be insulated.
- DO NOT insulate the first three (3) linear feet of the exhaust vent run.
- DO NOT insulate PVC, CPVC, or Polypropylene exhaust vent pipe material. Doing so will cause increased vent wall temperatures, which could result in vent pipe failure.
- CPVC, Polypropylene, or Stainless Steel pipe material MUST be used if the first three (3) linear feet of the exhaust vent run passes through an enclosed space greater than 6" in length, such as a wall or ceiling.\*
- If CPVC is used to meet these requirements, the balance may be installed with approved PVC pipe.
- If Polypropylene or Stainless Steel is used to meet these requirements, the balance of the vent run MUST be installed with the same material.
- Failure to comply with these requirements could result in property damage, severe personal injury, or death.

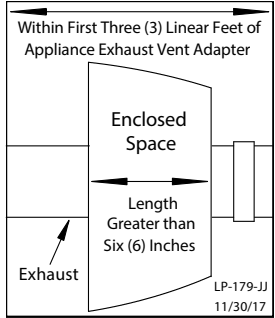

\*This rule applies when the exhaust vent passes through the enclosed space into another interior space, i.e. through a floor or wall from the mechanical room into another room. This rule DOES NOT apply when the exhaust vent passes through the enclosed space immediately to the exterior of the building.

## B. Approved Materials for Exhaust Vent and Intake Pipe

Item	Material	Standards for Installation In:	
		United States	Canada
<b>Pipe and Fittings Approved for Intake ONLY</b>	ABS*	ANSI/ASTM D2661	ANSI/ASTM D2661
<b>Pipe Approved for Intake OR Exhaust Vent</b>	PVC Schedule 40/80	UL-1738 or ANSI/ASTM D1785	UL-1738 or ULC-S636
	PVC-DWV Schedule 40/80	UL-1738 or ANSI/ASTM D2665	
	CPVC Schedule 40/80	UL-1738 or ANSI/ASTM F441	
	Polypropylene	UL-1738 or ULC-S636	
	Stainless Steel AL29-4C	Certified for Category IV and Direct Vent Appliance Venting	
<b>Pipe Fittings</b>	PVC Schedule 40	UL-1738, ANSI/ASTM D2466 or D2665	UL-1738 or ULC-S636
	PVC Schedule 80	UL-1738, ANSI/ASTM D2467 or D2665	
	CPVC Schedule 40	UL-1738 or ANSI/ASTM F438	
	CPVC Schedule 80	UL-1738 or ANSI/ASTM F439	
<b>Pipe Cement</b>	ABS*	ANSI/ASTM D2235	ULC-S636 Approved Cements and Primers
	PVC	ANSI/ASTM D2564	
	CPVC	ANSI/ASTM F493	
<b>Pipe Primer</b>	PVC / CPVC	ASTM F656	

### **DANGER**

- The exhaust and intake components installed with this appliance must be used for near appliance piping BEFORE transitioning to the approved materials listed above. DO NOT REMOVE these installed components. Doing so WILL VOID appliance warranty.
  - In the US/Canada, PVC vent pipe and fittings SHALL NOT BE USED within the closet or alcove. Only approved CPVC, Polypropylene, or Stainless Steel vent pipe and fittings may be used.
  - PVC / CPVC pipe and fittings of the same diameter are considered interchangeable.
  - The use of cellular core PVC (ASTM F891), cellular core CPVC, or Radel® (polyphenolsulfone) in exhaust venting systems is prohibited.
  - Covering non-metallic vent pipe and fittings with thermal insulation is prohibited.
  - When installing AL29-4C vent piping, DO NOT mix AL29-4C piping from different manufacturers unless using adapters specifically designed for the purpose by the manufacturer.
  - DO NOT mix components from different venting systems without proper adapters. The vent system could fail, causing leakage of flue products into the living space. Use only the approved pipe and fitting materials, and primer and cement specifically designed for the material used, as listed in the above table.
  - A double wall vent or insulated material may be used when using stainless steel vent material in a freezing climate.
  - \*ABS may be used for air intake applications ONLY.
  - Contact the venting material manufacturer if there is any question about the applicability of the proposed venting material.
- Failure to follow these directions will result in substantial property damage, severe personal injury, or death.

**Table 6 - Approved Materials for Exhaust Vent and Intake Pipe**

<b>CAUTION</b>
High heat sources (generating heat 100°F / 37°C or greater, such as boiler flue pipes, space heaters, etc.) may damage plastic components of the water heater as well as plastic vent pipe materials. Such damages ARE NOT covered by warranty. It is recommended to keep a minimum clearance of 8" from high heat sources. Observe heat source manufacturer instructions, as well as local, state, provincial, and national codes, laws, regulations, and ordinances when installing this water heater and related components near high heat sources.

**NOTE:** The use of double-wall vent or insulated material for the combustion air intake pipe is recommended in cold climates to prevent the condensation of airborne moisture in the incoming combustion air.

### **DANGER**

You must not use "B" vent in an exhaust application. "B" vent is for intake applications ONLY. Using "B" vent in an exhaust application will result in serious injury or death.

### C. Additional Requirements for Installation in Canada

1. Installations must be made with a vent pipe system certified to ULC-S636.
2. The first three (3) feet of vent pipe from the appliance flue outlet must be readily accessible for visual inspection.
3. The components of the certified vent system must not be interchanged with other vent systems or unlisted pipe / fittings.

**D. Exhaust Vent and Intake Pipe Location**

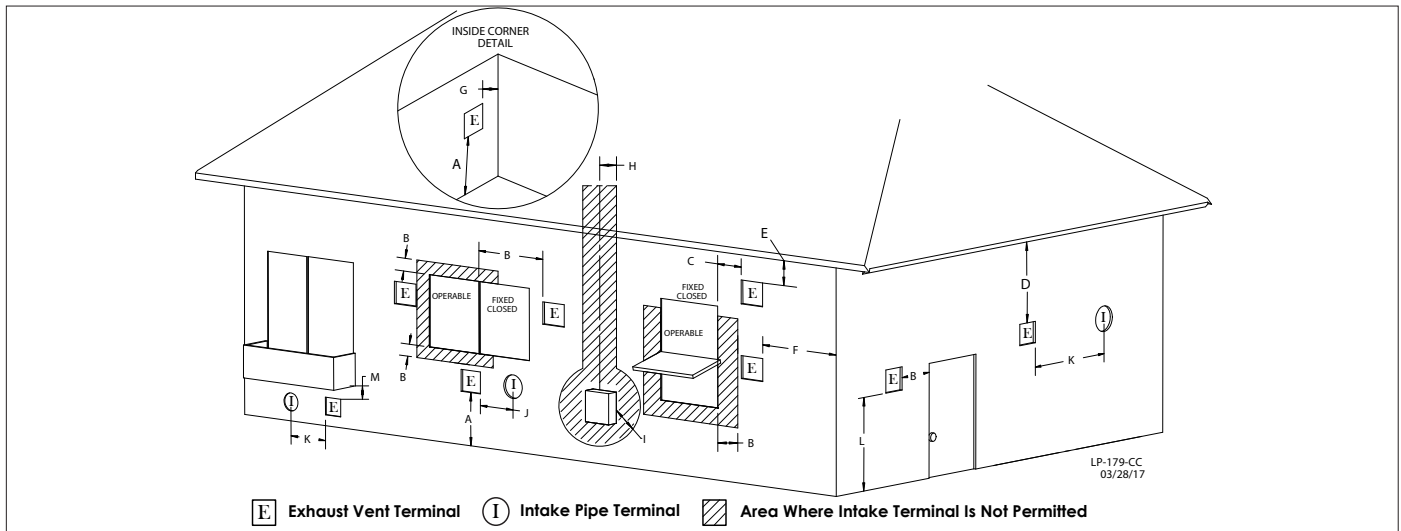

**Figure 14 - Exit Terminals for Direct Vent Systems - ANSI Z223.1 / NFPA 54 for US and CAN/CSA B149.1 for Canada**

DESCRIPTION		US	CANADA
<b>A</b>	Clearance above grade, veranda, porch, deck, or balcony	1 foot (30 cm)	
<b>B</b>	Clearance to window or door that may be opened	Direct Vent	3 feet (91 cm)
		Power Vent	
<b>C</b>	Clearance to permanently closed window	*	
<b>D</b>	Vertical clearance to ventilated soffit located above the terminal within a horizontal distance 2 feet (61 cm) from the center line of the terminal	*	
<b>E</b>	Clearance to unventilated soffit	*	
<b>F</b>	Clearance to outside corner	*	
<b>G</b>	Clearance to inside corner	*	
<b>H</b>	Clearance to each side of center line extended above meter / regulator assembly	*	
<b>I</b>	Clearance to service regulator vent outlet	*	Above a regulator within 3 feet (91 cm) horizontally of the vertical center line of the regulator vent outlet to a maximum vertical distance of 15 ft (4.5 m)
<b>J</b>	Clearance to nonmechanical air supply inlet to building or the combustion air inlet to any other appliance	Direct Vent	3 feet (91 cm)
		Power Vent	
<b>K</b>	Clearance to mechanical air supply inlet	3 feet above if within 10 feet horizontally	6 feet (1.83 m)
<b>L</b>	Clearance above paved sidewalk or paved driveway located on public property	Direct Vent	7 feet (2.13 m)
		Power Vent	
<b>M</b>	Clearance under veranda, porch deck, or balcony	*	1 foot (30 cm)

**Table 7 - Vent Termination Clearances - \*NOTE: For clearances not specified in ANSI Z223.1 / NFPA 54 for US and CAN/CSA B149.1 for Canada, please use clearances in accordance with local installation codes and the requirements of the gas supplier.**

**WARNING**

The building owner is responsible for keeping the exhaust and intake terminations free of snow, ice, or other potential blockages, as well as scheduling routing maintenance. Failure to keep the vent piping terminations clear and properly maintain the heater could result in property damage, severe personal injury, or death.

**WARNING**

For each floor containing bedroom(s), a carbon monoxide detector and alarm shall be placed in the living area outside the bedrooms, as well as in the room that houses the heater. Detectors and alarms shall comply with NFPA 720 (latest edition). Failure to comply with these requirements could result in product damage, severe personal injury, or death.

**E. Exhaust Vent and Intake Pipe Sizing**

- The exhaust vent and intake pipe size is 2" for 100 and 130kBTU models and 3" for 160 and 199kBTU models.
- The maximum total equivalent length of 2" exhaust vent and intake pipe **should not exceed 85 feet**. The maximum total equivalent length of 3" exhaust vent and intake pipe **should not exceed 200 feet**.
  - The equivalent length of elbows, tees, and other fittings are listed in the Friction Loss Table.

Friction Loss Equivalent in Piping and Fittings			
Fittings or Piping	Equivalent Feet		
	2"	3"	4"
90 Degree Elbow*	5'	5'	3'
45 Degree Elbow	3'	3'	1'
Coupling	0'	0'	0'
Air Inlet Tee	0'	0'	0'
Straight Pipe	1'	1'	1'
Concentric Kit	3'	3'	N/A
V500 2" Kit	1'	N/A	N/A
V1000 3" Kit	N/A	1'	1'
V2000 4" Kit	N/A	1'	1'

**Table 8 - \*Friction loss for long radius elbow is 1 foot less. NOTE: Consult Polypropylene venting instructions for friction loss and pressure drop equivalents.**

- For example: If the exhaust vent has two 90° elbows and 10 feet of PVC pipe we will calculate:  
 Exhaust Vent Equivalent Length = (2x5) + 10 = 20 feet.  
 Further, if the intake pipe has two 90° elbows, one 45° elbow, and 10 feet of PVC pipe, the following calculation applies:  
 Intake Pipe Equivalent Length = (2x5) + 3 + 10 = 23 feet.  
 Finally, if a concentric kit is used we find:  
 Total Equivalent Length = 20 + 23 + 3 = 46 feet.  
 The total equivalent length is 46 feet, well below the maximum of 85 feet for 2" pipe.
  - Effort should be made to keep a minimum difference in equivalent length between the exhaust vent and intake pipe.
3. The minimum total equivalent length is 16 feet.

**WARNING**

Failure to install the appliance within the minimum and maximum vent length requirements could result in improper product operation and property damage, serious personal injury, or death.

**F. Longer Vent Runs**

The maximum total equivalent length can be extended by increasing the diameter of both the exhaust vent and intake pipes equally. However, the transitions should begin a minimum of 15 equivalent feet from the water heater.

- The maximum total equivalent length for increased diameter vent pipes is 125 feet for 2" transitioning to 3" pipe (this length includes the minimum 15 total equivalent feet necessary for transition).  
**NOTE:** 3" vent pipe can be increased in diameter, but total equivalent length cannot be increased beyond 200 feet.
- Transitions should always be made in vertical sections of pipe to prevent the condensate from pooling in the vent pipe.

Standard Vent Connection and Maximum Total Equivalent Length	Reducing Coupling	Increased Vent Size and Maximum Total Equivalent Length
2" (85')	3" x 2"	3" (125')

**Table 9 - Vent Run Transition**

- If transition occurs at a distance greater than 15 equivalent feet from the water heater, the maximum equivalent length will be reduced.

**DANGER**

Total maximum equivalent length of increased diameter exhaust vent and intake pipe must not exceed the lengths defined in this manual. 125 maximum total equivalent feet for 2" increased to 3" vent pipe; 200 maximum total equivalent feet for any increase to 3" vent pipe diameter. Failure to keep the total equivalent length below the maximum lengths determined in this manual will result in faulty water heater operation, substantial property damage, serious personal injury, or death.

Transition Point (Ft. from Heater)	TEL of Oversized Vent Pipe (Ft.)*	Maximum TEL of all Vent Pipe (Ft.)
15	95	125
20	77 1/2	117 1/2
25	60 1/2	110 1/2
30	43	103
35	26	96
40	8 1/2	88 1/2
NONE	0	85

**Table 10 - TEL = Total Equivalent Length \*Oversized vent pipe diameter is 1" or greater than factory supplied connection.**

**G. Exhaust Vent and Intake Pipe Installation**

**WARNING**

All joints of positive pressure vent systems must be sealed completely to prevent leakage of flue products into the living space. Failure to do so could result in property damage, serious injury, or death.

- Use only solid PVC, CPVC, or stainless steel pipe or a Polypropylene vent system approved for use with Category IV appliances. ABS pipe material may be used on air inlet piping **only**.
- Remove all burrs and debris from joints and fittings.
- When using PVC or CPVC pipe, all joints must be properly cleaned, primed, and cemented. Use only cement and primer approved for use with the pipe material. Cement must conform to ASTM D2564 for PVC and ASTM F493 for CPVC pipe. **NOTE: DO NOT CEMENT POLYPROPYLENE PIPE.**
- Ensure the vent is located where it will not be exposed to prevailing winds.
- In all roof venting applications, exhaust discharge must point away from the pitch of the roof.
- If the exhaust vent is to be terminated in a walled off area (such as a roof with a parapet wall), ensure the exhaust vent terminates a minimum of 10' from nearest wall and extends level with or above the top of the wall. This will ensure flue gas does not get trapped and possibly recirculated into the intake air pipe, which could contaminate the combustion air.
- To prevent water leakage, install adequate roof flashing where the pipe enters the roof.
- If it can be avoided do not locate vent directly over public walkways, driveways, or parking lots in climates where freezing conditions are possible. Condensate could drip and freeze, resulting in a slip hazard or damage to vehicles or machinery.
- Due to potential moisture build-up, sidewall venting may not be the preferred venting option. To save time and cost, carefully consider venting installation and location.
- Horizontal lengths of exhaust vent must slope back towards the appliance not less than 1/4" per foot to allow condensate to drain from the vent pipe.

11. Do not terminate vent where vapors can accumulate and harm people or pets.

12. When it can be avoided, do not terminate vent where vapors can damage shrubs or plants. Such damages are not covered by product warranty.

13. Moisture in the exhaust gas will condense as it leaves the vent terminal. In cold weather this condensate can freeze on the exterior wall, under the eaves, and on surrounding objects, including shrubs. Some discoloration to the exterior of the building is to be expected. However, improper location or installation can result in severe damage to the structure or exterior finish of the building, and increase the opportunity for vent blockages and nuisance shutdowns.

14. In vacant chimney applications, install and seal a rain cap over existing chimney openings.

15. All piping must be fully supported. Use pipe hangers at a minimum of 4 foot intervals to prevent sagging of the pipe where condensate may form.

16. Do not use the heater to support any piping.

17. A screened straight coupling is provided with the heater for use as an outside exhaust termination.

18. A screened inlet air tee is provided with the heater to be used as an outside intake termination.

19. Maximum Snow Level Determination: These installation instructions reference snow levels in establishing a minimum height for the installation of exhaust vent or air intake terminations. Snow levels shall be determined as follows:

- a. The installation location may, by ordinance, designate how snow levels are calculated in that location; or
- b. In the absence of specific ordinances, snow levels shall be calculated from the average monthly maximum depth of snow accumulation as indicated by the National Weather Service’s 10 year statistics for the installation location/geographical area.

In addition:

- Total length of vent piping shall not exceed the limits specified in this manual.
- The vent piping for this direct vented appliance is approved for zero clearance to combustible construction.
- The flue products coming from the exhaust vent will create a large plume when the heater is in operation. Avoid venting in areas that will affect neighboring buildings or be considered objectionable.
- DO NOT locate exhaust vent or intake pipe in a parking area where machinery may damage the pipe.
- DO NOT vent near soffit vents, crawl space vents, or other areas where condensate or vapor could create a nuisance or hazard or cause property damage.
- DO NOT vent where condensate vapor could cause damage or could be detrimental to the operation of regulators, relief valve, or other equipment.

**In the Commonwealth of Massachusetts and as Required by State and Local Codes:**

The vented gas fueled appliance shall not be installed so its combustion, ventilation, or dilution air is obtained from a bedroom or bathroom.

Signage: Whenever any through-the-wall (horizontal or sidewall) vent is installed less than seven feet above the finished grade, a metal or plastic identification plate shall be permanently mounted to the exterior of the building at a minimum height of eight feet above grade directly in line with the exhaust vent terminal. The sign shall read, in print no less than 0.5 inches in size, "GAS VENT DIRECTLY BELOW. KEEP CLEAR OF ALL OBSTRUCTIONS".

Marking of Exhaust Vent and Intake Pipe: Piping used for ventilation, make-up, or combustion air intake shall be labeled as follows:

- a. Throughout the entire developed length:
  - i. Labels must be placed every ten feet for exposed/visible piping; or

- ii. Labels must be placed every three feet for concealed piping.
- b. At all changes of direction;
- c. On each side of a penetration through a partition, wall or ceiling; and
- d. The labels shall be black lettering that:
  - i. Indicates that the piping is used for ventilation, make-up, or combustion air intake, and
  - ii. The letters shall be sized equal to a minimum of the pipe diameter. However, for piping with a diameter exceeding two inches, said lettering does not need to be larger than two inches.

The following table lists optional exhaust/intake terminations available from HTP:

Description	Stock Code
2" PVC Concentric Termination Kit	KGAVT0501CVT
3" PVC Concentric Termination Kit	KGAVT0601CVT
2" Stainless Steel Termination Kit	V500
3" Stainless Steel Termination Kit	V1000
4" Stainless Steel Termination Kit	V2000
3" Polypro Vent Kit	8400P-001

**Table 11 - Optional Vent Kits**

**H. Applications**

**1. Direct Vent Installation of Exhaust and Intake**

If installing a direct vent option, combustion air must be drawn from the outdoors directly into the water heater intake, and exhaust must terminate outside. There are three basic direct vent options detailed in this manual: 1. Side Wall Venting, 2. Roof Venting, and 3. Unbalanced Venting.

Be sure to locate the heater such that the exhaust vent and intake pipe can be routed through the building and properly terminated. Different vent terminals can be used to simplify and eliminate multiple penetrations in the building structure (see Optional Equipment in Venting Section). The exhaust vent and intake pipe lengths, routing and termination methods must all comply with the methods and limits given in the Venting section of this manual.

When installing a combustion air intake from outdoors, care must be taken to utilize uncontaminated combustion air. **NOTE:** To prevent combustion air contamination, see Table 3.

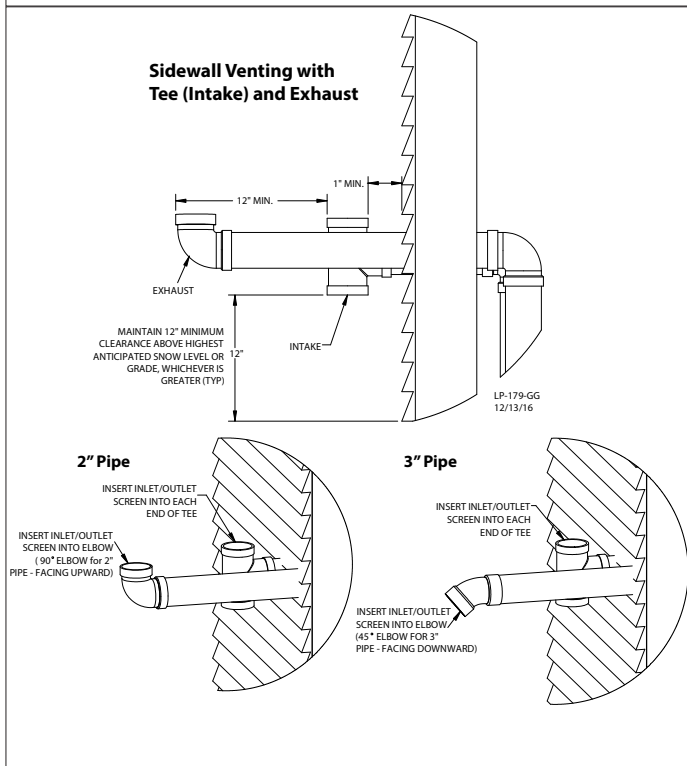
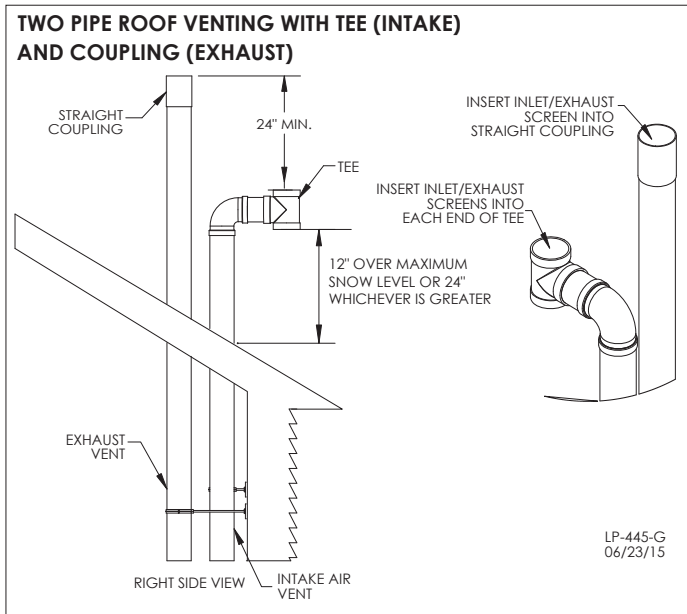

**Figure 15 - Two Pipe Roof and Sidewall Venting with Included Equipment (Tee and Coupling)**

**NOTE:** When installing two pipe sidewall venting, terminate 2" exhaust vent pipe with a 90° elbow, and 3" exhaust vent pipe with a 45° elbow. Failure to do so will result in improper appliance operation.

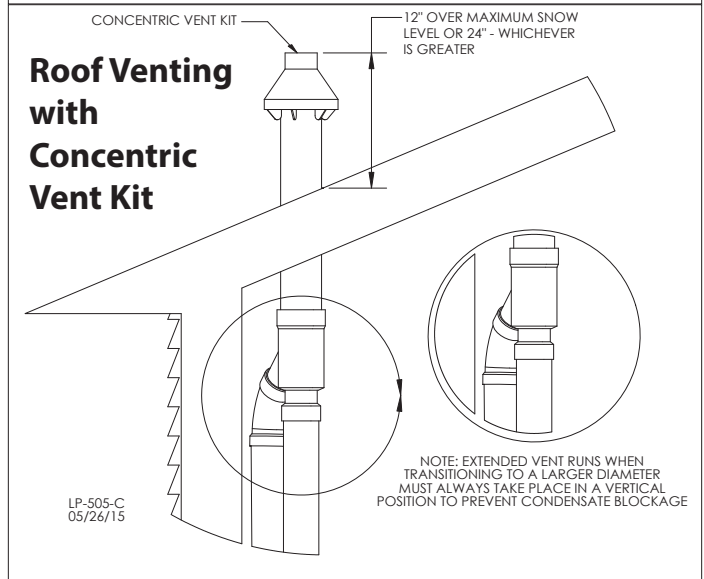
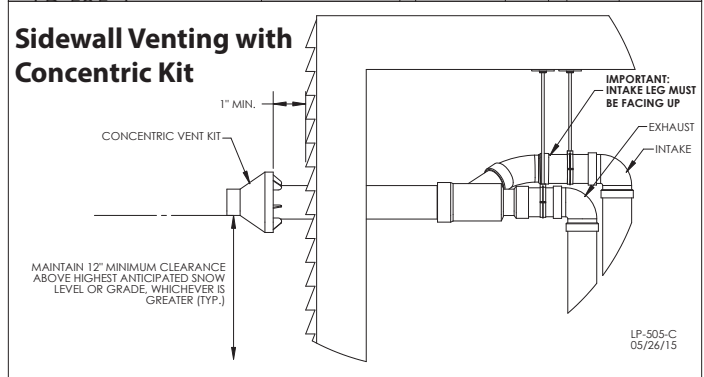
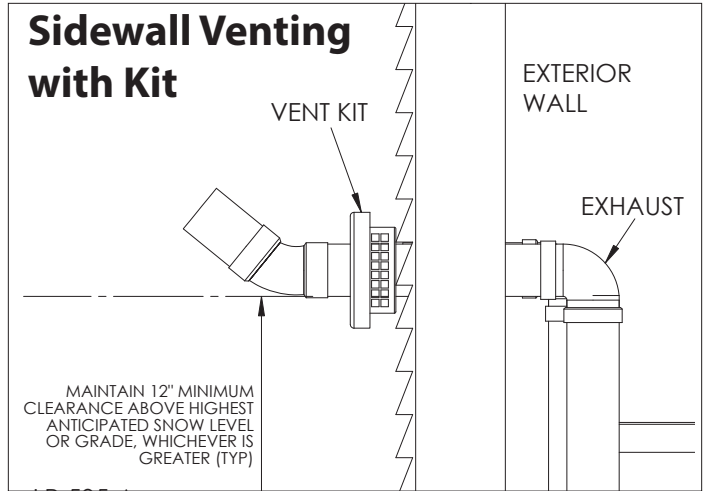

**Figure 16 - Venting with Optional Kits (NOT INCLUDED WITH THE WATER HEATER)**

**NOTE:** These drawings are meant to demonstrate system venting only. The installer is responsible for all equipment and detailing required by local codes.

**WARNING**

All vent pipes must be glued, properly supported, and the exhaust pitched a minimum of 1/4" per foot back to the heater to allow drainage of condensate. When placing support brackets on vent piping, the first bracket must be within 1 foot of the water heater and the balance of 4 foot intervals on the vent pipe. Venting must be readily accessible for visual inspection from the first three feet from the heater.

### Snorkel Venting (Two Pipe Sidewall Venting Terminations Beneath an Overhang)

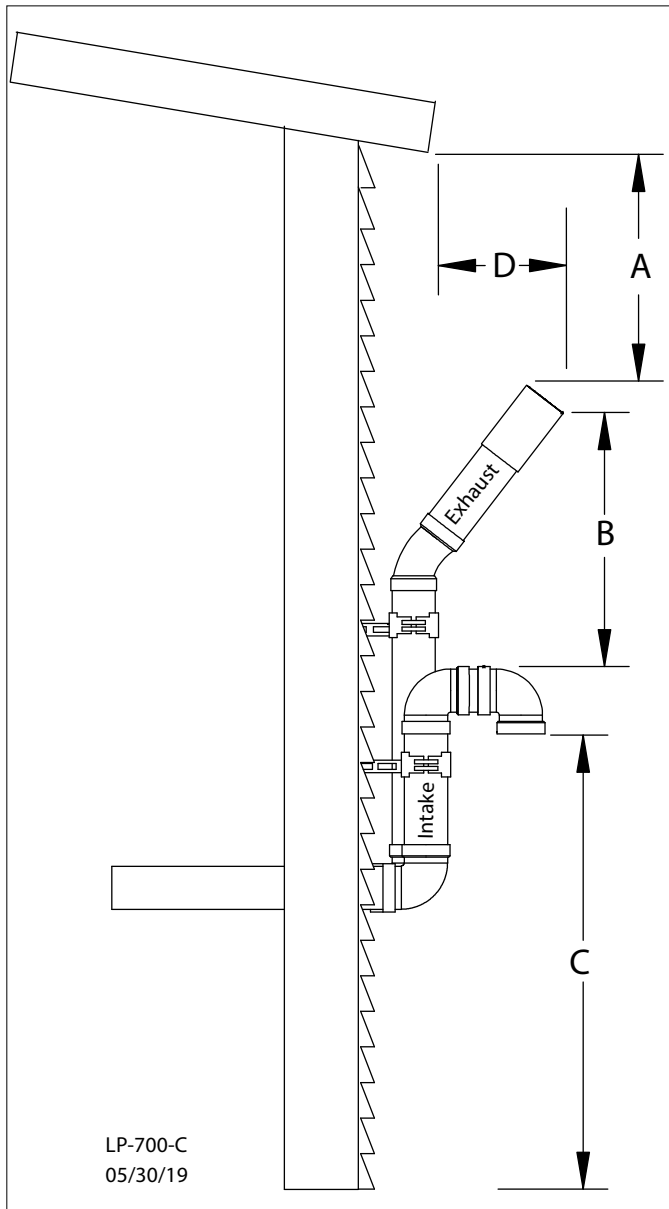

Figure 17 - Two Pipe Sidewall (Horizontal Snorkel) Venting

#### NOTES:

- A. For every 1" of overhang, the exhaust vent must be located 1" vertical below the overhang (12" minimum). Overhang means top of building structure (roof) and not two adjacent walls (corner of building).
- B. Maintain minimum separation between exhaust vent and air intake terminations, as required by local codes.
- C. Maintain 12" minimum clearance above highest anticipated snow level or grade (whichever is greater).
- D. The exhaust vent must extend a minimum of 12" to a maximum of 24" beyond the building.

**NOTE:** These drawings are meant to demonstrate system venting only. The installer is responsible for all equipment and detailing required by local codes.

### Venting Below Grade

For installations that exit the wall below grade:

1. Excavate the site to a point where the pipes are to exit as shown in Figure 18.
2. Ensure the wall is fully sealed where the pipes penetrate.
3. The exhaust vent / air intake piping **MUST** be secured to the side of the building above grade, as shown, to provide rigidity.
4. Ensure that the exhaust vent / air intake clearances are maintained.

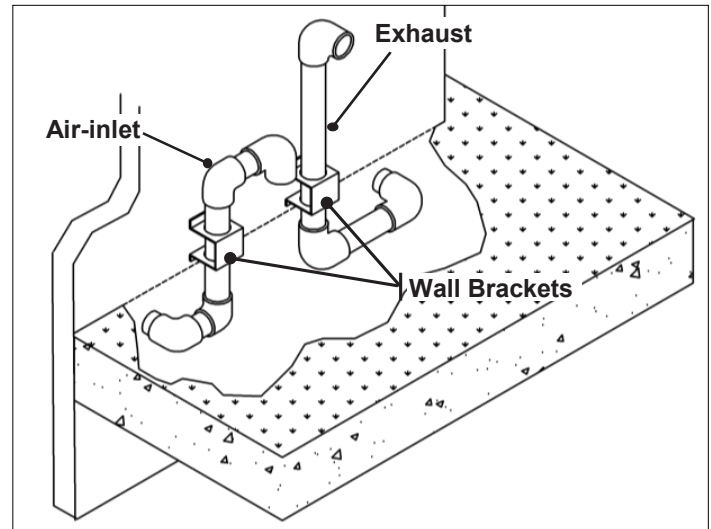

Figure 18 - Venting Below Grade

### Outdoor Venting

Vent piping outside the building is permitted under the following conditions:

1. The maximum length outside the building is 20 feet (6.1 m). Note that outdoor length must be included in the overall vent length calculation.
2. All normal termination clearances are maintained.
3. The pipe is supported every 24" (610 mm).
4. The exhaust and air intake are sloped back to the appliance 1/2" elevation for every linear foot (13 mm for every linear 305 mm).

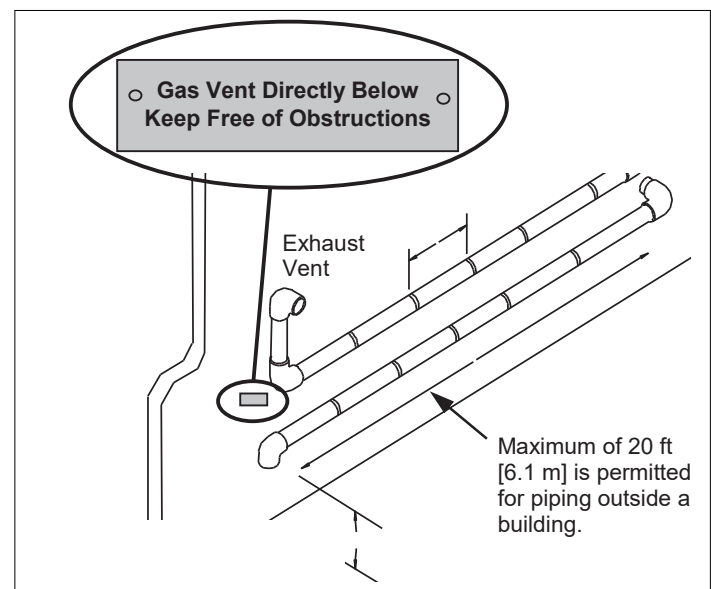
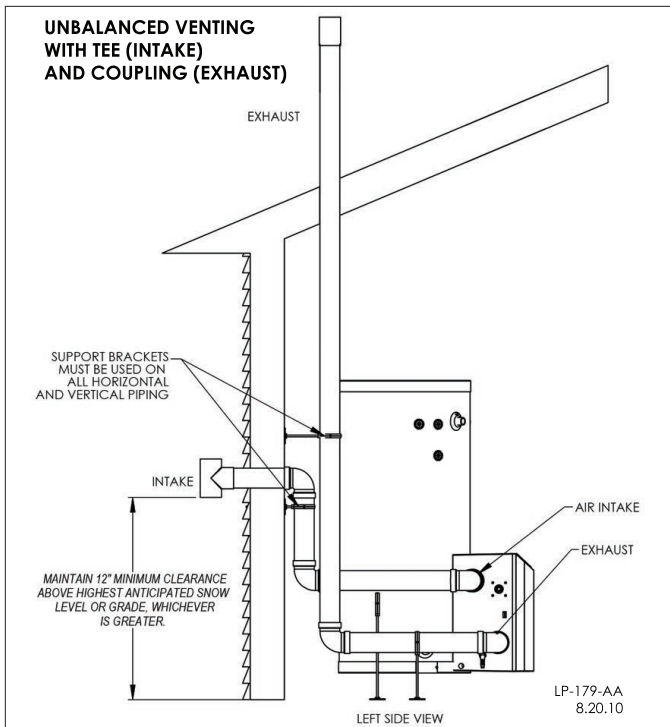

Figure 19 - Outdoor Venting



**Figure 20 - Unbalanced Venting - Roof Exhaust and Sidewall Intake**

**NOTE:** These drawings are meant to demonstrate system venting only. The installer is responsible for all equipment and detailing required by local codes.

## **WARNING**

All vent pipes must be glued, properly supported, and the exhaust pitched a minimum of 1/4" per foot back to the heater to allow drainage of condensate. When placing support brackets on vent piping, the first bracket must be within 1 foot of the water heater and the balance of 4 foot intervals on the vent pipe. Venting must be readily accessible for visual inspection from the first three feet from the heater.

## 2. Venting Through an Existing System

This heater may be vented through an existing unused vent system. The inner diameter of the existing vent system is utilized for the combustion air source. Two methods have been approved for such venting: Concentric Venting Through an Existing System and Venting as a Chase.

Vent / Air Inlet Size	Minimum Existing Vent / Chase Size
2"	4"
3"	5"
4"	7"

**Table 12 - Minimum Existing Vent / Chase Sizing**

**⚠ DANGER**

Do not install the heater into a common existing vent with any other appliance. This will cause flue gas spillage or heater malfunction, resulting in substantial property damage, serious personal injury, or death.

**CAUTION**

Contractors must check state and local codes before installing through an existing vent opening. State and local codes always take precedence over manufacturer's instructions. Failure to check state and local codes before installing through an existing opening could result in property damage and add significantly to installation costs.

If an existing venting system is converted for use with this heater, the installer must ensure that the existing venting system is clean and free from particulate contamination that could damage the heater. Failure to do so could result in property damage and heater failure. Such failure IS NOT covered under warranty.

## Concentric Venting Through an Existing System

NOTE: The following instructions refer only to venting through an existing vent system, and not to venting with HTP's optional concentric vent kits. Refer to Concentric Vent Kit installation manual (LP-166) for further information on venting with the optional concentric vent kits. Concentric venting through an existing system must run vertically through the roof. Use only the approved venting materials specified in Table 6 for piping the system. All instructions listed in this Venting section apply. See Figures 21-1 and 21-2 for venting demonstrations.

**⚠ DANGER**

The upper and lower vent terminations as well as all joints in the venting system must be properly sealed to ensure that all combustion air is drawn properly and exhaust does not leak from the system. Failure to properly seal the venting system will result in property damage, serious personal injury, or death.

## Chase Venting Through an Existing System

When venting as a chase, follow all instructions included in this Venting section, including those in the previous Concentric Venting Through an Existing System section. See Figure 21-3 for chase venting demonstration.

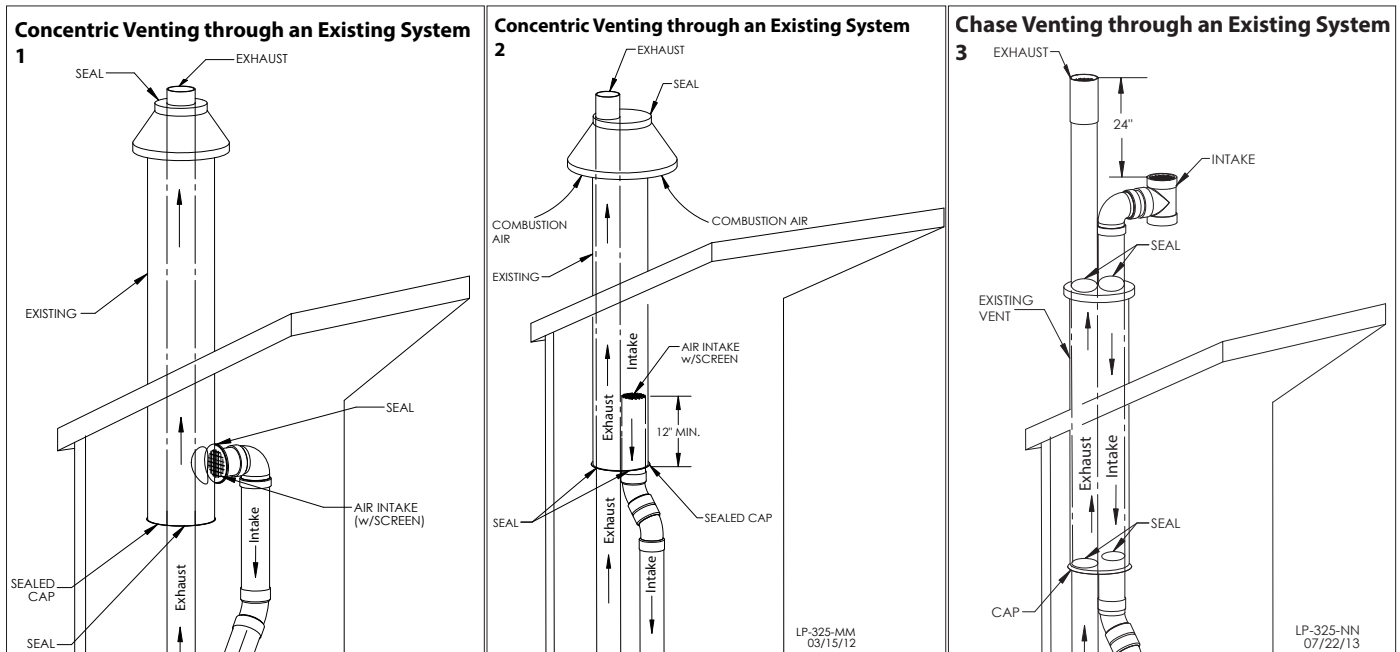

**Figure 21 - 1, 2 - Concentric Venting Through an Existing System, 3, Chase Venting Through an Existing System**

**NOTE:** These drawings are meant to demonstrate system venting only. The installer is responsible for all equipment and detailing required by local codes.

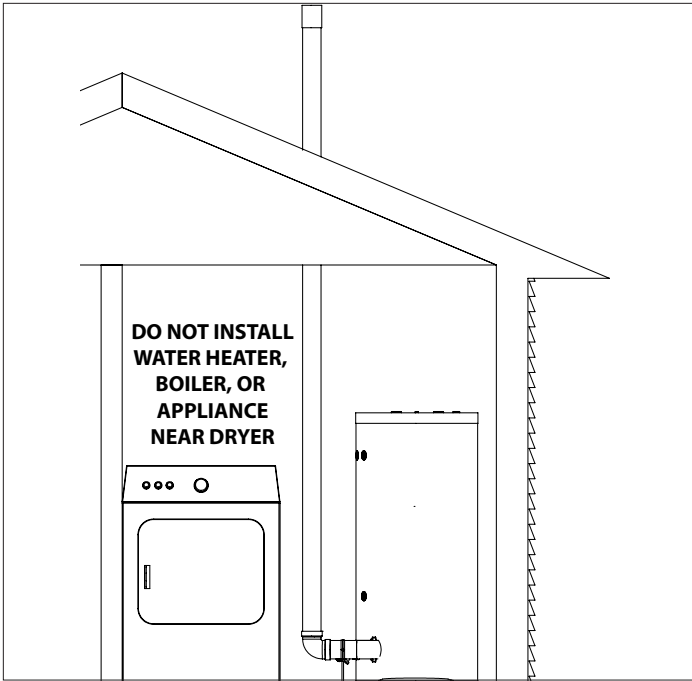

Figure 22 - Do Not Place Appliance Near Dryer

**3. Power Venting, Indoor Combustion Air in Confined or Unconfined Space**

This heater requires fresh, uncontaminated air for safe operation and must be installed in a mechanical room where there is adequate combustion and ventilating air. **NOTE: To prevent combustion air contamination, see Table 3.**

Combustion air from the indoor space can be used if the space has adequate area or when air is provided through a duct or louver to supply sufficient combustion air based on the water heater input. **Never obstruct the supply of combustion air to the water heater.** If the water heater is installed in areas where indoor air is contaminated (see Figure 22) it is imperative that the water heater be installed as direct vent so that all combustion air is taken directly from the outdoors into the water heater intake connection.

**Unconfined space** is space with volume greater than 50 cubic feet per 1,000 Btu/hour (4.8 cubic meters per kW) of the total input rating of all fuel-burning appliances installed in that space. Rooms connected directly to this space, through openings not furnished with doors, are considered part of the space.

**Confined space** is space with volume less than 50 cubic feet per 1,000 Btu/hour (4.8 cubic meters per kW) of the total input rating of all fuel-burning appliances installed in that space. Rooms connected directly to this space, through openings not furnished with doors, are considered part of the space.

When drawing combustion air from inside a conventionally constructed building to a confined space, such space should be provided with two permanent openings: one located 6" (15 cm) below the space ceiling, the other 6" (15cm) above the space floor. Each opening should have a free area of one square inch per 1,000 Btu/hr (22cm<sup>2</sup>/kW) of the total input of all appliances in the space, but not less than 100 square inches (645cm<sup>2</sup>).

If the confined space is within a building of tight construction, air for combustion must be obtained from the outdoors as outlined in the Venting section of this manual. See Figure 23.

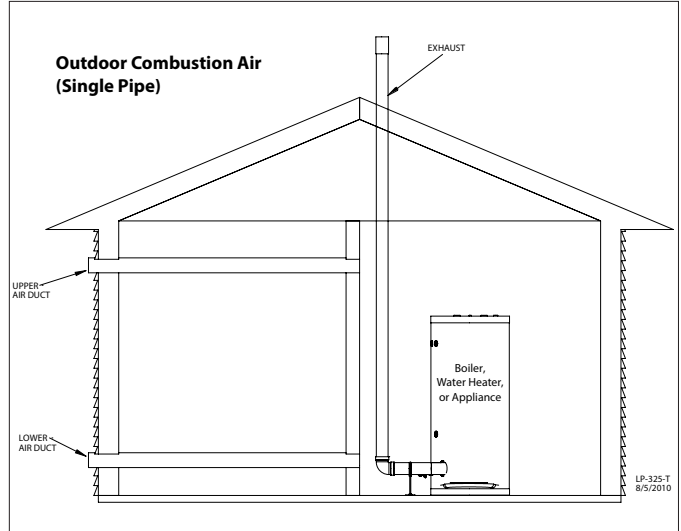
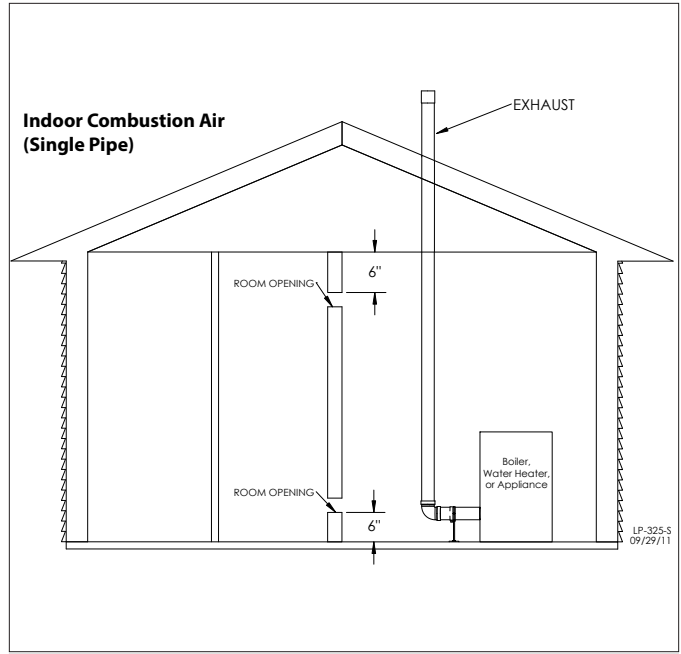



Figure 23 - Indoor and Outdoor Combustion Air - Single Pipe

**⚠ WARNING**

**Breathing Hazard - Carbon Monoxide Gas**



- Do not operate heater if flood damaged.
- Install vent system in accordance with local codes and manufacturers installation instructions.
- Do not obstruct heater air intake or exhaust. Support all vent piping per manufacturers installation instructions.
- Do not place chemical vapor emitting products near unit.
- According to NFPA 720, carbon monoxide detectors should be installed outside each sleeping area.
- Never operate the heater unless it is vented to the outdoors.
- Analyze the entire vent system to make sure that condensate will not become trapped in a section of vent pipe and therefore reduce the open cross sectional area of the vent.

Breathing carbon monoxide can cause brain damage or death. Always read and understand instruction manual.

LP-304

## Part 6 - Condensate Removal

### CAUTION

This condensing high efficiency appliance has a condensate removal system. Condensate is water vapor derived from combustion products, similar to that produced by an automobile when it is initially started. It is very important that the condensate line is sloped down away from the appliance and to a suitable drain.

The condensate line must remain unobstructed. If allowed to freeze in the line or obstructed in any other manner, condensate can exit from the appliance tee, resulting in potential water damage to property.

When installing a condensate pump, select one approved for use with condensing boilers and furnaces. The condensate pump should have an overflow switch to prevent property damage from spillage.

Condensate from the appliance will be slightly acidic (pH from 3.2 to 4.5). Check with your local gas company to determine if combustion condensate disposal is permitted in your area. Install a neutralizing filter if required by local codes.

### WARNING

Power to the optional condensate pump is continuous. When the water heater is powered off the condensate pump will remain on. It is important to remember to turn off the condensate pump when powering down the water heater. Failure to do so could result in property damage, severe personal injury, or death.

#### NOTES:

1. Due to its efficient design, the appliance produces condensate (water) as a normal by-product. This condensate is acidic, with a pH level between 2 and 4.5. This condensate must be drained away from the appliance and disposed in accordance with all local regulations.
2. The condensate line should be as short as possible and must be pitched at least  $\frac{1}{4}$ " per foot to properly drain. If this cannot be done, increase the condensate line and place a tee in the line to properly reduce vacuum lock in the drain line. Tees should be placed after the condensate neutralizer (if used).
3. Use corrosion-resistant materials to drain condensate. Use flexible plastic hose or tube, PVC, or CPVC pipe. PVC or CPVC pipe must comply with ASTM D1785, F441, or D2665. Cement must comply

with ASTM D2564 for PVC pipe or F493 for CPVC pipe. For Canadian applications, use CSA or ULC certified flexible tube, PVC or CPVC pipe, fittings, and cement.

4. If using flexible tube, place an overflow tee in the tube line to prevent condensate backing up into the appliance if the tube should kink. Ensure the overflow tee is positioned near a drain or in a location that will not damage the surrounding area.

5. Do not reduce the size of the condensate line. The line must at minimum equal the diameter of the line included with the appliance.

6. A frozen condensate line could result in a blocked vent condition. It is very important to protect the condensate line from freezing temperatures or any type of blockage. In installations that may encounter sustained freezing conditions, the use of heat tape is recommended to avoid freezing of the condensate line. Longer condensate runs are more prone to freezing.

7. Support of the condensate line may be necessary to avoid blockage of the condensate flow.

8. Local building codes may require an in-line neutralizer to be installed (not included) to treat the condensate. See Figure 24. If required by local authorities, a condensate filter of lime crystals, marble, or phosphate chips will neutralize slightly acidic condensate (p/n 7450P-212 available from HTP). Follow all the installation instructions included with the neutralizer. If a neutralizer is installed, periodic replacement of the limestone (or neutralizing agent) will be required. The rate of depletion of the limestone varies with usage of the appliance. During the first year of appliance operation, check the neutralizer every few months for depletion.

9. Route the drain line to a nearby floor drain, laundry tub, or condensate pump. If the appliance condensate outlet is lower than the drain, you must use a condensate removal pump (kit p/n 554200 available from HTP).

**NOTE:** If a nearby laundry tub is used as a disposal for waste water from the washing machine, draining the condensate into this tub allows the soapy water discharge to neutralize the acidic condensate.

10. An error will appear on the appliance display if condensate line is blocked. The appliance will not operate with a blocked condensate line. It is extremely important to have this condition repaired by a qualified service technician.

11. Damages due to frozen or blocked condensate lines or leaks ARE NOT covered by warranty.

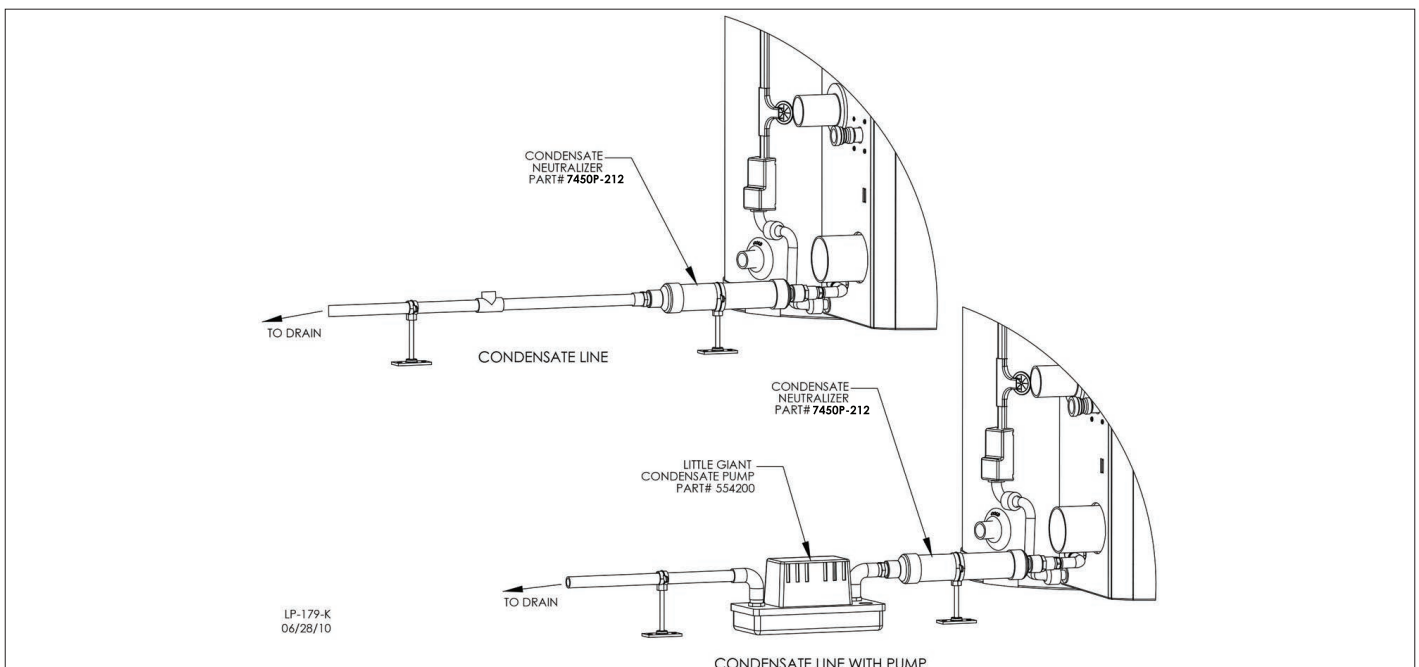

Figure 24 - Condensate Piping

**Part 7 - Wiring**

**⚠ WARNING**

Install wiring and electrically ground water heater in accordance with the authority having jurisdiction or, in the absence of such an authority, follow the National Electrical Code, NFPA 70, and/or CSA C22.1 Electrical Code-Part 1 in Canada. Failure to follow all applicable local, state, and national regulations, mandates, and building supply codes for guidelines to install the electrical power supply could result in property damage, serious personal injury, or death.

**ELECTRICAL SHOCK HAZARD** – To ensure safety, turn off electrical power supply at service entrance panel before making any electrical connections to avoid possible electric shock hazard. Failure to do so could result in property damage, serious personal injury, or death.

Jumping out control circuits or components WILL VOID product warranty and can result in property damage, personal injury, or death.

It is of extreme importance that this unit be properly grounded. It is very important that the building system ground is inspected by a qualified electrician prior to making this connection. Electrical power must only be turned on when the heater is completely filled with cold water. Failure to follow these instructions could result in component or product failure, serious injury, or death.

**⚠ CAUTION**

Label all wires prior to disconnecting them when servicing the heater. Wiring errors can cause improper and dangerous operation. Failure to follow these instructions may result in property damage or personal injury.

**A. Line Voltage Input**

The heater must be wired to a 120 volt circuit by a qualified electrician. It is recommended that the heater be wired on its own circuit to minimize the possibility of circuit failure due to outside clauses. The heater requires a maximum of 8 amps at 120 volts in use.

**B. Line Voltage Condensate Output**

The heater has the capability of supplying power to a condensate pump. The connection is 120 VAC +/- 10% at a max of 2 amps. Power is supplied to the pump only when the heater is connected to power, and the power switch is in the on position.

**C. Low Voltage Outdoor Sensor Input**

The heater has the capability of an outdoor reset. Connecting an outdoor sensor allows the heater to operate at optimum efficiency. HTP offers an outdoor sensor, p/n 7250P-319. The outdoor sensor must be a 12K NTC sensor. Use a minimum 22 AWG wire for runs of 100 feet or less and minimum 18 AWG wire for runs up to 150 feet. Instructions are included with the outdoor sensor to correctly mount the sensor on the exterior surface of the building. It is preferable to mount the sensor on the north side in an area that will not be affected by direct sunlight but will be exposed to varying weather conditions. Connect the outdoor sensor to terminals marked "Outdoor".

**⚠ WARNING**

An ASSE 1017 thermostatic mixing valve **MUST** be installed when using 0-10V or outdoor reset. Failure to do so could result in substantial property damage, serious injury, or death.

**D. Alarm Connections**

The control includes an alarm output. This circuit is rated at 3 amps at 120 volts. This contact can be used to activate an alarm light or bell or notify a building management system if the water heater goes into a lockout condition.

**E. Optional 0-10 Volt Building Control Signal**

A signal from a building management system may be connected to the water heater to enable remote control. This signal should be a 0-10 volt positive-going DC signal. When this input is enabled using the installer menu, a building control system can be used to control the set point temperature of the water heater. The control interprets the 0-10 volt signal as follows; when the signal is between 0 and 1.5 volts, the water heater will be in stand-by mode, not firing. When the signal rises above 1.5 volts, the water heater will ignite. As the signal continues to rise towards its maximum of 10 volts, the water heater will increase in set point temperature. See Part 10 for details on the setting of function 16.

NOTE: During 0-10V operation, the minimum tank temperature set point (default 95°F) will be at the activation input of 1.5 volts. The maximum temperature set point value will be at the input voltage of 10 volts. The maximum temperature set point can be changed by increasing or decreasing the **DU** setting (Range: 77°F – 160°F / Default 119°F). Once programmed, the 0-10V feature will change the set point temperature automatically.

1. Connect a building management system or other auxiliary control signal to the terminals marked 0-10 VOLT + and 0-10 VOLT – in the electronics assembly (shown in Figure 25). Caution should be used to ensure that the 0-10 VOLT + connection does not become connected to ground.
2. Configuring the appliance for 0-10 volt operation (change only the functions in the descriptions below):
  - a. Press and hold **S3** and **S4** together for 5 seconds
  - b. Use **S1** and **S2** to adjust flashing **000** to code **975**. Press **S3** until you enter the menu.
  - c. Use **S3** to scroll to Function 16 to enable/disable 0-10 volt operation. Use **S1** and **S2** to adjust display to desired setting (Range: 0 = Off, 2 = On / Default Off).
  - d. Press and hold **S4** to exit the menu.

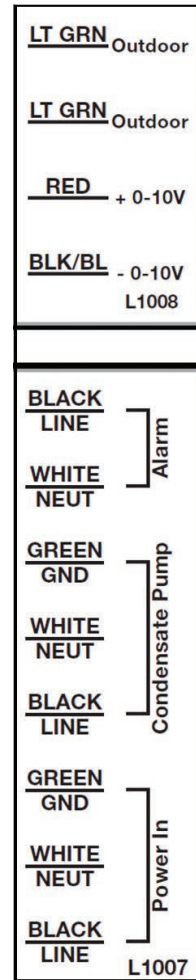

Figure 25 - Field Wiring

F. Internal Wiring Diagram

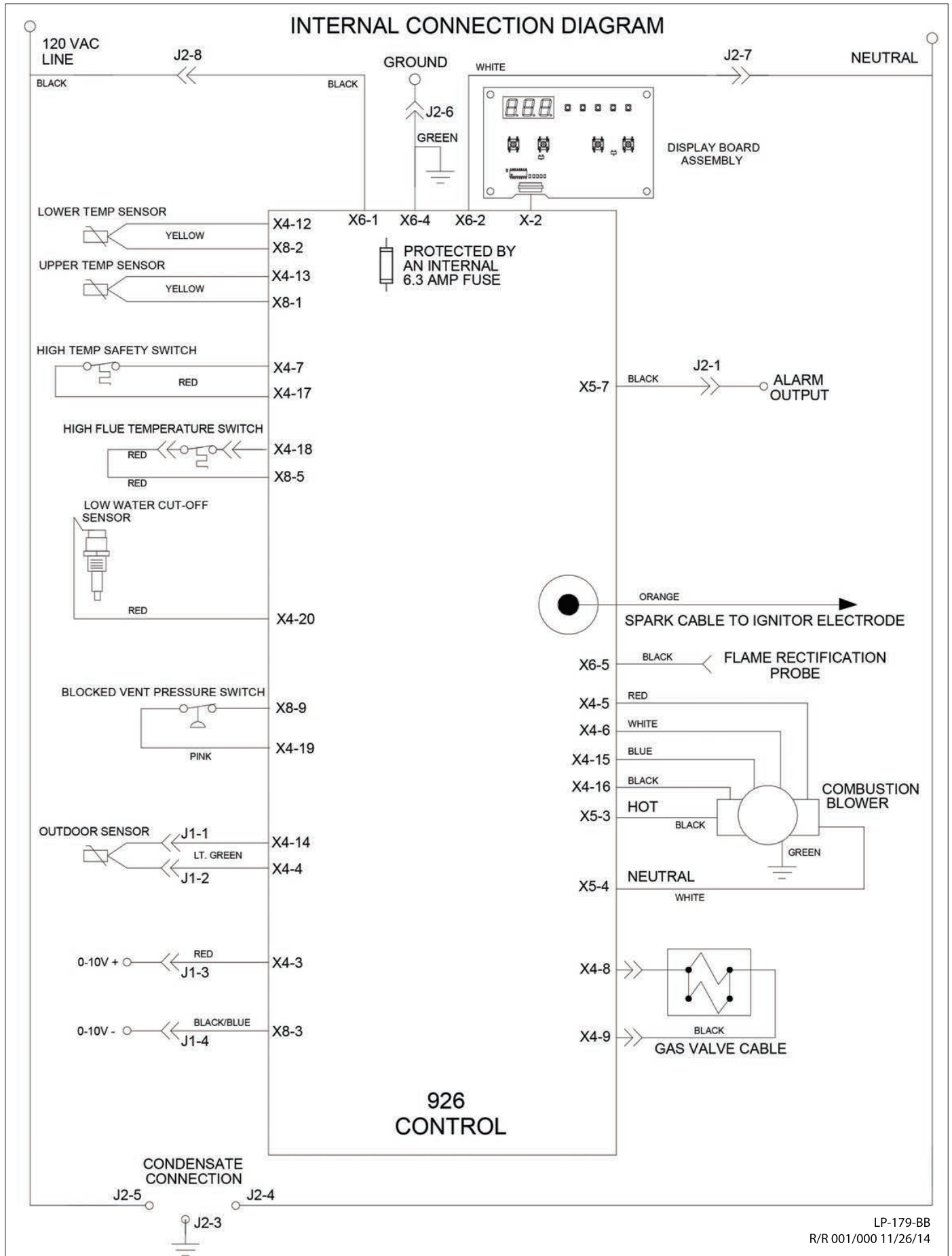
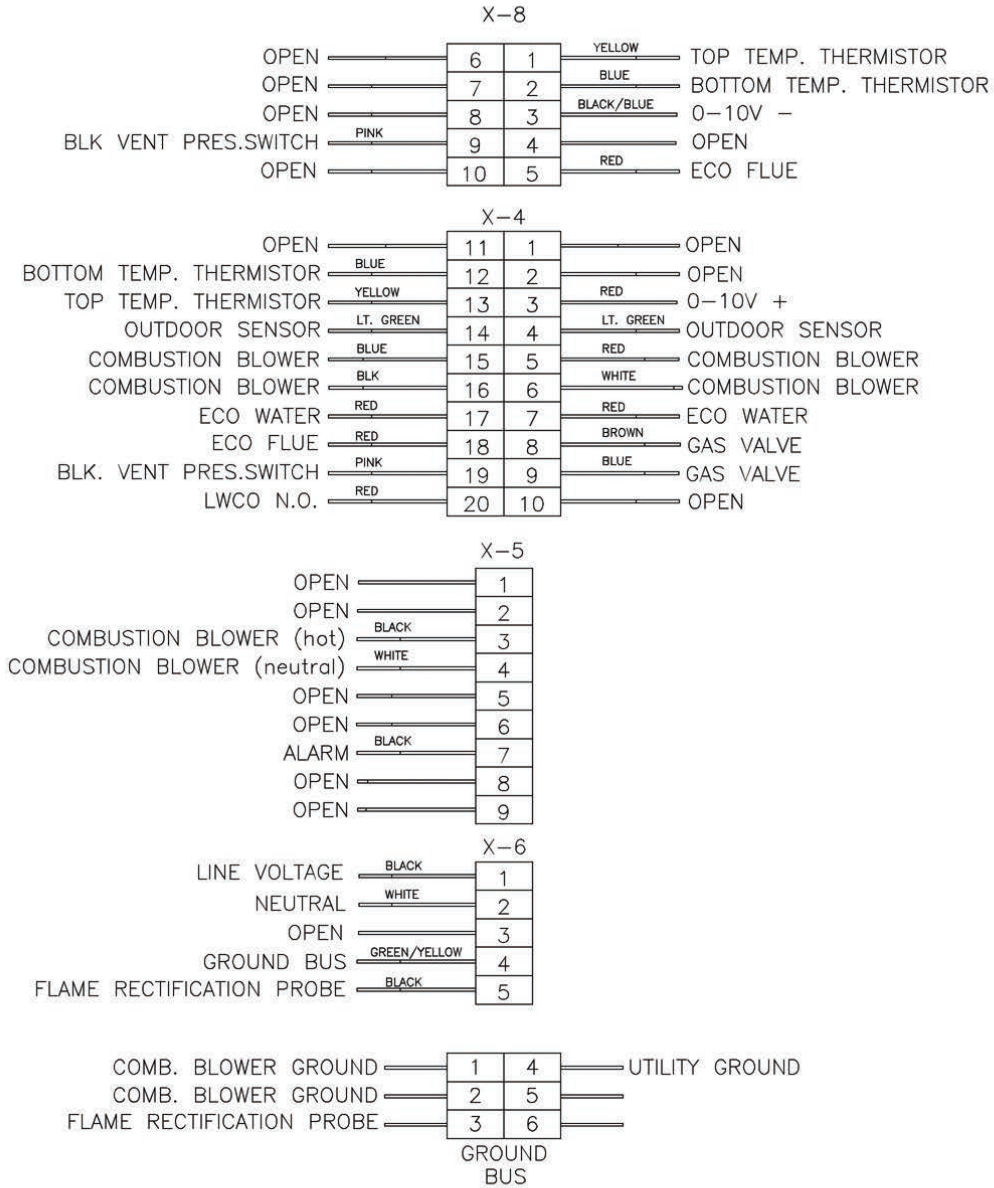

Figure 26 - Internal Wiring Diagram

LP-179-BB  
R/R 001/000 11/26/14

### CONTROL BOARD



### EXTERNAL 10 PIN CONNECTOR

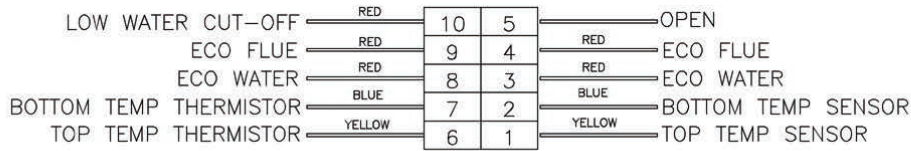

LP-179-L  
11/26/14

Figure 27 - Control Board Wiring

**Part 8 - Gas Connections**

**! WARNING**

**FIRE AND/OR EXPLOSION HAZARD**

To avoid serious injury or death, the gas line installation and the gas line inlet pressure test must be done by a licensed professional.

Ensure the gas on which the boiler will operate is the same type specified on the rating plate (natural gas or LP gas). This boiler must be converted to propane operation. Follow Gas Conversion Manual instructions (separate document). Failure to follow these instructions could result in property damage, personal injury, or death.

Make sure the gas line pressures are within normal limits. Pressures outside normal limits can result in poor performance and hazardous operating conditions, property damage, personal injury, or death.

**NOTICE**

Do not operate the boiler on Natural Gas or LP gas with average sulfur rates greater than 30 mg/m<sup>3</sup>. Doing so could result in improper product operation and failure, and WILL VOID the boiler warranty.

**A. Gas Pipe Sizing Tables**

**1. Gas Pipe Sizing**

This information is for reference use only. Refer to gas pipe manufacturer specifications for actual delivery capacity. The DOE standard for Natural Gas is 1100 BTU/ft<sup>3</sup>. Contact the local gas supplier for actual BTU/ft<sup>3</sup> rating.

**2. Natural Gas Pipe Sizing**

The following table lists maximum capacity of pipe in cubic feet of gas per hour for gas pressures of 14" or less and a pressure drop of 0.5 inches water column, based on a 0.60 specific gravity for natural gas.

**3. LP (Liquid Propane) Gas Pipe Sizing**

Contact gas supplier to size pipes, tanks, and 100% lockup gas pressure regulator. Adjust propane supply regulator provided by the gas supplier for 14 inches w.c. maximum pressure.

Pipe Size (in.)	Length of Pipe (Feet)										BTU's Per Hour x 1,000	
	10	20	30	40	50	60	80	100	150	200		
3/4	360	247	199									Schedule 40 Metallic Pipe  (0.60 Specific Gravity, 0.5 WC Pressure Drop)
1	678	466	374	320	284	257	220					
1 1/4	1390	957	768	657	583	528	452	400	322	275		
1 1/2	2090	1430	1150	985	873	791	677	600	482	412		
2	4020	2760	2220	1900	1680	1520	1300	1160	928	794		
3	11300	7780	6250	5350	4740	4290	3670	3260	2610	2240		
4	23100	15900	12700	10900	9660	8760	7490	6640	5330	4560		

**Table 13 - Source - ANSI Z223.1**

The gas supply shall have a minimum of no less than 3.5" water column, a maximum inlet pressure of no greater than 14" water column (350 mm), and 1/2 pound pressure (3.5 kPa). The entire piping system, gas meter, and regulator must be sized properly to prevent excessive pressure drop (greater than 0.5" WC) as stated in the National Fuel Gas Code. This information is listed on the rating plate. It is very important that the water heater is connected to the gas type noted on the rating plate: "LP" for liquefied petroleum, propane gas, or "Nat" for natural or city gas. All gas connections must be approved by the local gas supplier or utility, in addition to the governing authority, prior to turning the gas supply on.

Do not remove the adaptor in Figure 28! It is mandatory that this fitting is used for connection to a field fabricated drip leg per the National Fuel Gas Code. You must ensure that the entire gas line to the connection at the appliance is no smaller than 3/4".

If the water heater experiences a pressure drop greater than 1" WC, the meter, regulator, or gas line is undersized or in need of service. A manometer can be attached to the incoming gas drip leg by removing the cap. The gas pressure must remain between 3.5" and 14" WC during stand-by (static) mode and while in operating (dynamic) mode at full output.

If an in-line regulator is used, it must be installed a minimum of 10 feet from the heater. It is very important that the gas line is properly purged by the gas supplier or utility. Improper line sizing or failure

to properly purge the lines will result in ignition failure. This problem is especially noticeable in NEW LP installations, in empty tank situations, or when a utility company shuts off service to an area to maintain supply lines.

Once all inspections have been performed, the piping must be leak tested. If the leak test requirement is a higher test pressure than the maximum gas inlet pressure, isolate the heater from the gas line to continue leak testing. To do this, turn off the factory and field-installed gas cocks. Failure to do so may damage the gas valve.

In the event the gas valve is exposed to a pressure greater than 1/2 PSI, 14" water column, the gas valve must be replaced. The gas valve must not be replaced with a conventional gas valve under any circumstances. As an additional safety feature, the gas valve in this water heater has a flanged connection to the swirl plate and blower.

**! WARNING**

UL recognized fuel gas detectors are recommended in all enclosed propane and natural gas applications where there is a potential for an explosive mixture of fuel gas to accumulate. The installation of these detectors should be made in accordance with the detector manufacturer's recommendations, and/or local laws. Failure to install fuel gas detectors in these applications could result in fire, explosion, property damage, severe personal injury, or death.

**B. Gas Connection Requirements**

**⚠ WARNING**

Support gas supply piping with hangers, not by the heater or its accessories. The heater gas valve and blower will not support the weight of the piping. Make sure the gas piping is protected from physical damage and freezing, where required. Failure to follow these instructions could result in gas leakage, fire, explosion, property damage, severe personal injury, or death.

Do not use Teflon tape on gas line pipe thread. Use a pipe compound rated for use with natural and propane gases. Apply sparingly on male pipe ends, leaving the two end threads bare. Failure to follow these instructions could result in gas leakage, fire, explosion, property damage, severe personal injury, or death.

1. The gas adapter fitting on the water heater is 3/4" NPT. **NOTE:** The gas supply pipe size must not be less than 3/4".
2. The supply line must be sized for the maximum output of the water heater being installed. If there are additional gas appliances on the main supply line, size the supply line for the maximum total COMBINED BTU/Hr draw of the appliances. This will ensure the supply line is sized to allow all the appliances to operate at the same time.
3. Measure the length of the gas supply line from the gas meter to the water heater. The water heater must be installed downstream of the gas meter to ensure adequate gas supply.
4. Use the table in this manual or refer to the gas line manufacturer's sizing information to determine the correct supply pipe size. Run the gas supply line in accordance with all applicable codes.
5. The National Fuel Gas Code (NFPA 54) requires that a sediment trap (drip leg) be installed in the gas line on appliances not so equipped. The drip leg must be accessible, a minimum of 3" in length, and not subject to freezing conditions. See Figure 28.
6. A manual gas shut-off valve should be installed in the gas supply line close to the water heater. Locate and install manual shutoff valves in accordance with local and state requirements.
7. To facilitate any future maintenance, it is also recommended that an approved gas union fitting be installed in the supply line between the shut-off valve and the 1/2" NPT connection on the water heater.
8. Use a manometer to test the gas pressure to make sure it meets the minimum standards and does not exceed the maximum standards of the water heater.
9. Leak test the gas line pipe before placing the water heater in operation. Only use approved leak detector liquid solutions to check for leaks. Never use an open flame to check for leaks.

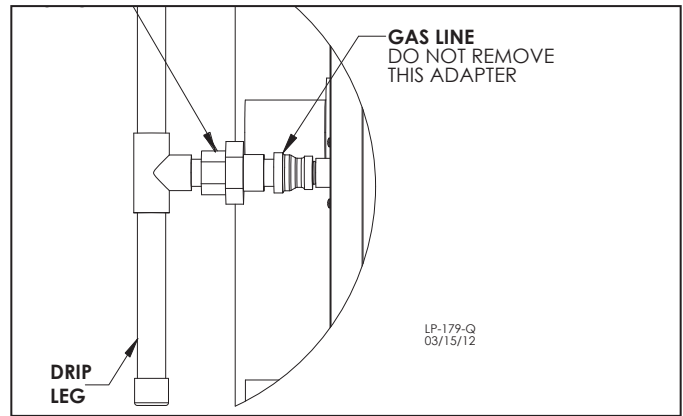

**Figure 28 - Gas Connection**

**C. Additional Precaution for Excess Flow Valve (EFV)**

If an excess flow valve (EFV) is in the gas line, check the manufacturer's minimum and maximum flow capacity ratings. An improperly sized EFV will not allow for a full flow of gas to the appliance and will cause the appliance to malfunction. See Figure 29.

**⚠ WARNING**

When performing a pressure test on the gas line piping, be sure the appliance is disconnected or isolated if the test pressure is expected to exceed 1/2 PSI (14" WC), as damage to the gas valve could occur. Such damage could result in fire, property damage, serious personal injury, or death.

**⚠ WARNING**

**Breathing Hazard - Carbon Monoxide Gas**

- Do not operate heater if flood damaged.
- Install vent system in accordance with local codes and manufacturers installation instructions.
- Do not obstruct heater air intake or exhaust. Support all vent piping per manufacturers installation instructions.
- Do not place chemical vapor emitting products near unit.
- According to NFPA 720, carbon monoxide detectors should be installed outside each sleeping area.
- Never operate the heater unless it is vented to the outdoors.
- Analyze the entire vent system to make sure that condensate will not become trapped in a section of vent pipe and therefore reduce the open cross sectional area of the vent.

**Breathing carbon monoxide can cause brain damage or death. Always read and understand instruction manual.**

LP-304



**Figure 29 - Excess Flow Valve (EFV)**

**D. Gas Valve**

**⚠ DANGER**  
 Do not do a gas conversion on this appliance without an officially approved conversion kit and instructions supplied by HTP. Failure to use a conversion kit when converting the appliance to fire on Natural or Propane gas will result in extremely dangerous burner operation, leading to fire, explosion, severe personal injury, or death.

**⚠ WARNING**  
 Strain on the gas valve and fittings may result in vibration, premature component failure and gas leakage, and result in fire, explosion, property damage, severe personal injury, or death.

Adjustments to the throttle screw or offset may only be made by a qualified gas technician using a calibrated combustion analyzer capable of measuring CO<sub>2</sub> and CO. Failure to follow this instruction could result in fire, explosion, property damage, severe personal injury, or death.

**E. Checking Gas Pressure at the Water Heater for Proper Operation**

**NOTE:** Refer to Figure 30 when checking gas pressure.

1. The water heater and its individual shutoff valve must be disconnected from the gas supply piping system during any pressure testing of the system at pressures greater than ½ psi (3.5 kPa).
2. The water heater must be isolated from the gas supply piping system by closing its individual manual shutoff valve during any pressure testing of the gas supply piping system at test pressures equal to or less than ½ psi (3.5 kPa). Loosen the screw on the pressure tap inlet to attach a manometer and check the gas inlet pressure.

The minimum and maximum inlet gas line pressures must meet the requirements shown in Table 14.

Natural or LP Gas	
Minimum Pressure	3.5"WC
Maximum Pressure	14"WC

**Table 14 - Gas Pressure Requirements**

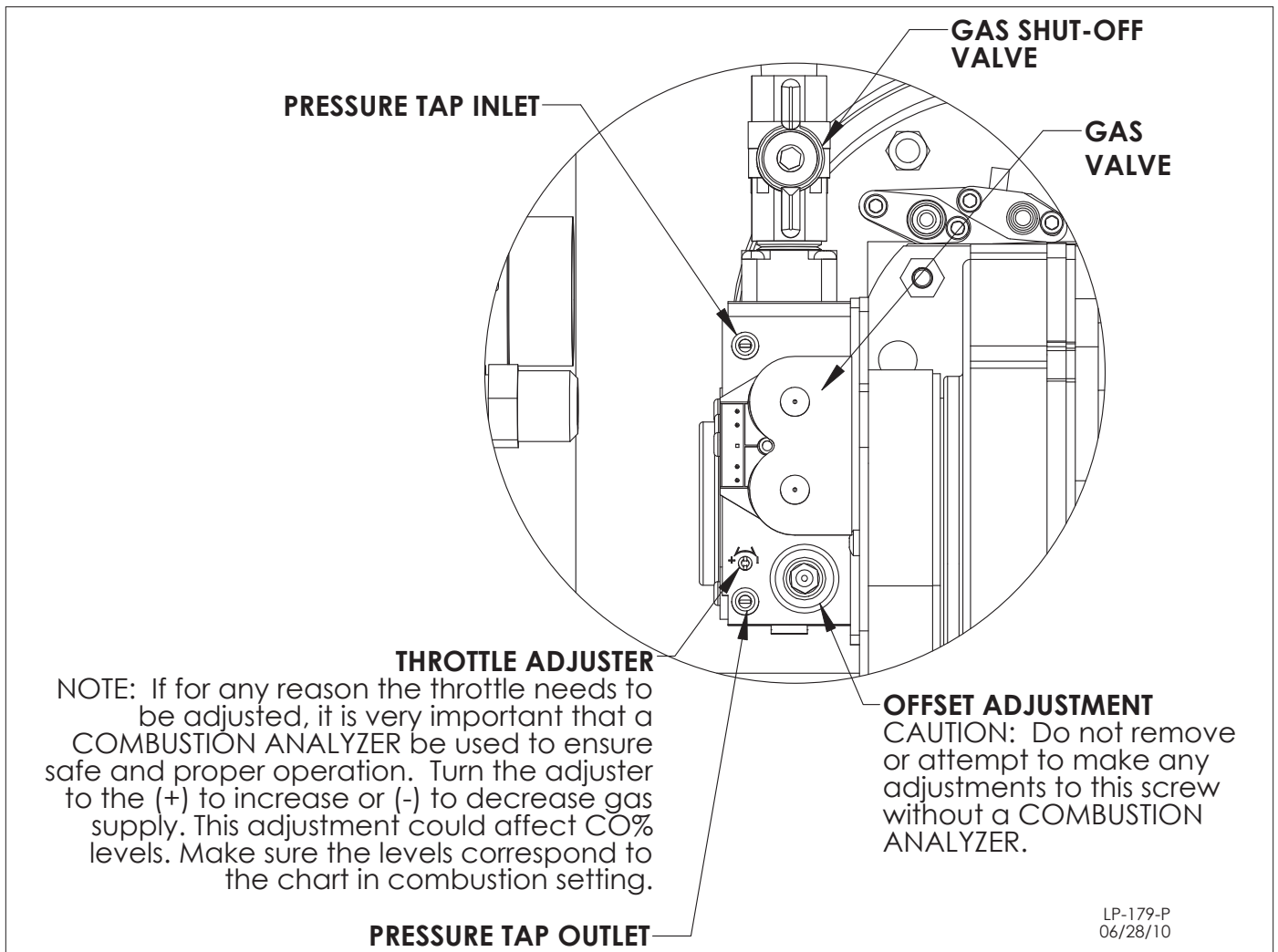

**Figure 30 - Gas Valve**

## Part 9 - Start-Up Preparation

### CAUTION

Thoroughly clean and flush any system before installing the water heater.

### A. Check / Control Water Chemistry

#### CAUTION

Chemical imbalance of the water supply may affect efficiency and cause severe damage to the appliance and associated equipment. Water quality must be professionally analyzed to determine whether it is necessary to treat the water. Various solutions are available to adjust water quality. Adverse water quality will affect the reliability of the system. In addition, operating temperatures above 135°F will accelerate the build-up of lime scale and possibly shorten appliance service life. Failure of an appliance due to lime scale build-up, low pH, or other chemical imbalance IS NOT covered by the warranty.

The water must be potable, free of corrosive chemicals, sand, dirt, and other contaminants. It is up to the installer to ensure the water does not contain corrosive chemicals or elements that can damage the heat exchanger. Potable water is defined as drinkable water supplied from utility or well water in compliance with EPA secondary maximum contaminant levels (40 CFR Part 143.3). If the water contains contaminants higher than outlined by the EPA, water treatment is recommended and additional, more frequent maintenance may be required.

If you suspect that your water is contaminated in any way, discontinue use of the appliance and contact an authorized technician or licensed professional.

- **Water pH between 6.5 and 8.5**
  - pH levels below 6.5 can cause an increase in the rate of corrosion. pH of 8.5 or higher can potentially cause lime scale build-up
  - Maintain water pH between 6.5 and 8.5. Check with litmus paper or have it chemically analyzed by a local water treatment company.
  - If the pH is not between 6.5 and 8.5, consult a local water treatment company for solutions.
- **Hardness less than 12 grains (200 mg/L) (Residential Use - water temperatures below 140°F)**
- **Hardness less than 7 grains (120 mg/L) (Commercial Use - water temperatures of 140°F and greater)**
  - Hardness levels above the required amounts can lead to lime scale build-up throughout the system. Water below 5 grains/gallon (85 mg/L) may be over softened.
  - Consult local water treatment companies for unusually hard water areas (above the required amounts) or for other treatment solutions if water is being over softened (below 5 grains/gallon [85 mg/L]).
- **Chloride concentration less than 100 ppm (mg/L)**
  - Do not fill water heater or operate with water containing chlorides in excess of 100 ppm (mg/L).
  - Using chlorinated fresh water should be acceptable as levels are typically less than 5 ppm (mg/L).
  - Do not connect the water heater to directly heat swimming pool or spa water.
- **Total Dissolved Solids (TDS) less than 500 ppm (mg/L)**
  - Total dissolved solids are minerals, salts, metals, and charged particles that are dissolved in water.
  - The greater the amounts of TDS present, the higher the

corrosion potential due to increased conductivity in the water.

- If using softened water to fill the water heater, it is still possible to have high TDS. This water can be corrosive. Consult local water treatment companies for other treatment solutions to reduce this effect.

**\*NOTE:** To promote water heater service life, it is strongly recommended to follow the maintenance procedures in this manual.

### B. Check for Gas Leaks

#### WARNING

Before starting the appliance, and during initial operation, smell near the floor and around the appliance for gas odor or any unusual odor. Remove appliance front door and smell interior of appliance enclosure. Do not proceed with startup if there is any indication of a gas leak. Repair any leaks at once.

**PROPANE ONLY** – The propane supplier mixes an odorant with the propane to make its presence detectable. In some instances the odorant can fade, and the gas may no longer have an odor. Before startup (and periodically thereafter), have the propane supplier verify the correct odorant level in the gas.

If you discover any evidence of a gas leak shut down the appliance at once. Find the leak source with a bubble test and repair immediately. Do not start the appliance again until the leak is repaired. Failure to comply could result in substantial property damage, severe personal injury, or death.

### C. Fill and Test Water System

#### WARNING

The water heater must be full of water and the system fully purged BEFORE powering the water heater. When filling the water heater, open a hot water tap to release air in the water heater and piping. All air has been purged from the system when water runs freely from the faucets.

Applying power to the water heater when it is not full of water will damage the heat exchanger, and could result in property damage, serious personal injury, or death. Such damages ARE NOT covered by water heater warranty.

- Ensure any drain valves are completely closed.
- Open the shut-off valve in the cold water supply line.
- Open the hot water faucets to allow air to vent from the heater and piping.
- Allow sufficient time for the heater to completely fill with water.

### D. Condensate Removal

1. The water heater is a high efficiency condensing water heater. Therefore, the unit has a condensate drain. Condensate fluid is nothing more than water vapor, derived from combustion products, similar to that produced by an automobile when it is initially started.

Condensation is slightly acidic (typically with a pH of 3 to 5) and must be piped with the correct materials. Never pipe the condensate using steel, copper, brass or other materials that will be subject to corrosion. Plastic PVC or CPVC pipe are the only approved materials.

A condensate neutralizer, if required by local authorities, can be made up of lime crystals, marble or phosphate chips that will neutralize the condensate. This may be done by the installer or you may purchase a condensate neutralizer (7450P-212).

2. The water heater is equipped with a ¾ female socket weld fitting connection that must be piped to a local drain. It is very important that the condensate line is sloped downward away from the water heater to a suitable inside drain. If the condensate outlet on the appliance is lower than the drain, you must use a condensate removal pump

(554200). This pump is equipped with two leads that can be connected to an alarm or another type of warning device to alert the user of a condensate overflow, which, if not corrected, could cause property damage.

3. If a long horizontal run is used, it may be necessary to create a vent in the horizontal run to prevent a vacuum lock in the condensate line.
4. Do not expose the condensate to freezing temperatures.
5. It is very important you support the condensation line to assure proper drainage.

### Part 9 - Start-Up Procedure

#### **WARNING**

##### **FOR YOUR OWN SAFETY READ BEFORE OPERATING**

1. This water heater does not have a pilot. It is equipped with an ignition device which automatically lights the burner. Do not try to light the burner by hand.
2. BEFORE OPERATING: Smell all around the water heater area for gas. Be sure to smell next to the floor because some gas is heavier than air and will settle on the floor.

##### **WHAT TO DO IF YOU SMELL GAS**

- Do not try to light any water heater.
- Do not touch any electric switch, do not use any phone in your building.
- Immediately call your gas supplier from a neighbor's phone. Follow the gas suppliers' instructions.
- If you cannot reach your gas supplier, call the fire department.
- Turn off the gas shutoff valve (located outside the water heater) so that the handle is crosswise to the gas pipe. If the handle will not turn by hand, don't try to force or repair it, call a qualified service technician. Force or attempted repair may result in a fire or explosion.

4. Do not use this water heater if any part has been under water. Immediately call a qualified service technician to inspect the water heater and to replace any part of the control system and any gas control that has been damaged.

5. The water heater shall be installed so the gas ignition system components are protected from water (dripping, spraying, rain, etc.) during water heater operation and service (circulator replacement, condensate trap, control replacement, etc.)

Failure to follow these instructions could result in property damage, serious personal injury, or death.

#### **A. Operating Instructions**

If you smell gas, STOP. Follow listed safety instructions above. If you do not smell gas, follow the next steps.

1. Make sure tank is full with cold water and purge all piping. To assure adequate purging, open all hot water faucets.

#### **WARNING**

Ensure the water heater is full of water before firing the burner. Failure to do so will damage the heater. Such damage IS NOT covered by warranty, and could result in property damage, serious personal injury, or death.

2. Turn on all electric power to water heater.
3. Adjust the temperature set point of the heater to the desired level. The factory default setting is 119°F. If changes are necessary, follow "Overall Water Heater and Control Operation" in this section.
4. If the water heater fails to start, refer to the Troubleshooting section in the back of this manual.

#### **B. Overall Water Heater and Control Operation**

To adjust the temperature of stored water, press and hold **S3** for 2 seconds. The first item is **du**: Water Temperature Set Point - factory set at 119°F. Adjust down by pressing **S1** to a temperature as low as 95°F. Adjust up as high as 160°F by pressing **S2**. Press **S3** again to display **dh**:

Differential, which is factory set at 7°F and adjustable down to 1°F by pressing **S1** and up to 18°F by pressing **S2**. NOTE: Due to the highly advanced control on this water heater, which compensates for varying inlet water temperature, the actual differential temperature may vary slightly from the setting. Press **S3** again to display the factory default temperature measurement in Fahrenheit. Change the default to Celsius by pressing **S1**. When finished, press **S3** one final time to place unit back in operation. The control automatically restarts if no key is pressed for 2 minutes.

**NOTE:** If Outdoor Reset is used, Function 9 must match the **du** setting. Failure to match Function 9 and the **du** setting will result in improper water heater operation.

#### **C. Status Menu**

Installers are also able to check the current status of the heater parameters by pressing **S4** for 3 seconds. Once activated, the display will show **d1** alternating with the actual upper supply tank temperature. Actual values are displayed for each function. To view the next value, simply press **S4** to go to the next displayed value. Listed below are the values which can be displayed. These values cannot be changed. To exit this menu, press **S3** to resume normal operation.

Function	Value
<b>d1</b>	Actual temperature from upper tank sensor
<b>d2</b>	Actual temperature from lower tank sensor
<b>d3</b>	<b>0</b> - Not Used
<b>d4</b>	<b>308</b> - Not Used
<b>d5</b>	Outdoor Sensor
<b>d6</b>	Actual Fan Speed divided by 10 (Example: If fan speed displayed is <b>410</b> x 10 = 4100 RPM actual fan speed)
<b>d7</b>	Actual Ionization Current read from flame rectification probe
<b>d8</b>	<b>0</b> - Not Used
<b>d9</b>	<b>1</b> - Not Used
<b>d10</b>	Actual status of bus communication - <b>co</b> = connected, <b>nc</b> = not connected
<b>d11</b>	<b>32</b> - Not Used
<b>d12</b>	Power on hours in thousands (display will not read until 100 hours)
<b>d13</b>	Total water heating hours in thousands (display will not read until 100 hours)
<b>d14</b>	<b>0</b> - Not Used
<b>d15</b>	Passed ignition attempts in thousands

**Table 15 - Status Menu Functions and Values**

#### **D. Outdoor Reset**

**NOTE:** The outdoor reset function cannot be used if the 0-10 volt function is enabled.

This unit is supplied with outdoor reset wire connection terminals. **When an outdoor sensor (p/n 7250P-319) is connected, operation of the unit immediately changes.** Refer to the following steps to properly set up the unit with an outdoor sensor.

#### **WARNING**

An ASSE 1017 thermostatic mixing valve MUST be installed when using outdoor reset. Failure to do so could result in substantial property damage, severe personal injury, or death.

1. Connect the outdoor sensor to the terminals marked "outdoor".
2. Press and hold **S3**. An alternating **du** and temperature value will appear on the display. Set **du** to the maximum desired tank temperature (default 119°F). After setting the temperature, press **S3** to exit the menu.

3. Setting the outdoor reset curve (change only the functions listed in the descriptions below):

- a. Press and hold **S3** and **S4** together for 5 seconds.
- b. Use **S1** and **S2** to adjust the flashing **000** to code **975**. Press **S3** until you enter the menu.
- c. Use **S3** to scroll to Function 8 to adjust minimum outdoor temperature. Use **S1** and **S2** to adjust temperature to desired setting (Range: -49°F - 32°F / Default 5°F).
- d. Use **S3** to scroll to Function 9 to adjust maximum water heater storage temperature. Use **S1** and **S2** to adjust temperature to desired setting (Range: 77°F - 160°F / Default 119°F). **NOTE:** Function 9 must match the **du** setting.
- e. Use **S3** to scroll to Function 10 to adjust maximum outdoor temperature (warm weather shutdown temperature). Use **S1** and **S2** to adjust temperature to desired setting (Range: 32°F - 95°F / Default 68°F).
- f. Use **S3** to scroll to Function 11 to adjust minimum water heater storage temperature. Use **S1** and **S2** to adjust temperature to desired setting. This temperature must be set to the maximum desired DHW temperature (Range: 32°F - 160°F / Default 159°F).
- g. Use **S3** to scroll to Function 12 to adjust desired DHW temperature (minimum tank temperature). Use **S1** and **S2** to adjust temperature to desired setting (Range: 32°F - 160°F / Default 95°F).
- h. Press and hold **S4** to exit the menu.

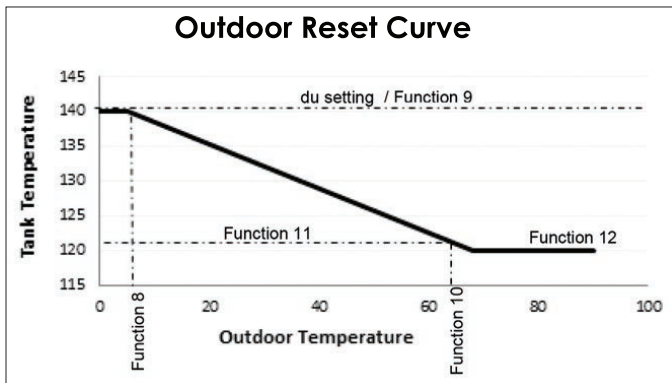
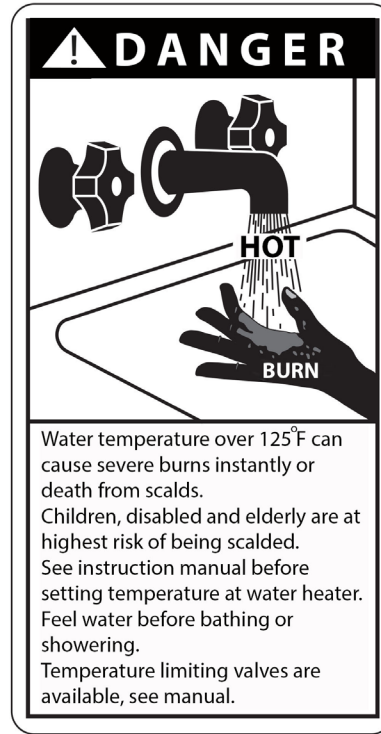

Figure 31 - NOTE: The maximum tank temperature is 160°F, independent of all settings described above.

**E. Test Mode**

This function is intended to simplify gas valve adjustment if necessary. Listed on the following page are recommended limits on each heater and the combustion settings. Automatic modulation does not take place when the controller is in Test Mode, only temperature limitation based on the heater set point. Fan speed can be increased or decreased by pressing either **S1** or **S2**.

To activate Test Mode, press **S2** and **S3** simultaneously for 1 second. Once activated, **Ser** will display and alternate with the actual fan speed. The measurement of the combustion levels should always be taken at the highest and lowest fan speed. When in Test Mode, the heater's limit will shut down the burner if temperature limit is exceeded. It is recommended to draw water out of the tank to lower temperature so tests can be performed.

After 10 minutes, Test Mode stops automatically. To exit Test Mode, press **S1** and **S2** simultaneously for 1 second.

**WARNING**

It is very important that the combustion system be set within the recommended CO measurements listed below. Visually looking at the burner does not determine combustion quality. Failure to measure combustion with a calibrated Combustion Analyzer and set the throttle within the recommended CO measurements could result in property damage, severe personal injury, or death.

Combustion Settings on All Models						
Fan Speed	Natural Gas (NG)			Propane (LP)		
	Low	Ignition	High	Low	Ignition	High
<b>Carbon Monoxide (CO) PPM</b>	1-10	2-15	2-20	1-10	2-15	2-20
<b>Carbon Dioxide (CO<sub>2</sub>) %</b>	8-10			8 1/2- 10 1/2		9-11

Table 16 - Combustion Settings - All Models

Fan Speeds			
BTU	Ignition	Min	Max
<b>100,000</b>	3000	2000	5500
<b>130,000</b>			7300
<b>160,000</b>		2100	9100
<b>199,000</b>			

Table 17 - Fan Speeds

**F. Maintenance**

The control system requires no periodic maintenance under normal conditions. However, in unusually dirty or dusty conditions, periodic vacuuming of the cover to maintain visibility of the display and indicators is recommended. In dirty environments, such as construction sites, care must be taken to keep the water heater burner cover in place and drywall or saw dust away from water heater.

**CAUTION**

In unusually dirty or dusty conditions care must be taken to keep water heater burner door in place. Failure to do so VOIDS warranty.

**WARNING**

Allowing the heater to operate with a dirty combustion chamber will hurt operation. Failure to clean the heat exchanger as needed by the installation location could result in heater failure, property damage, personal injury, or death. Such product failures ARE NOT covered under warranty.

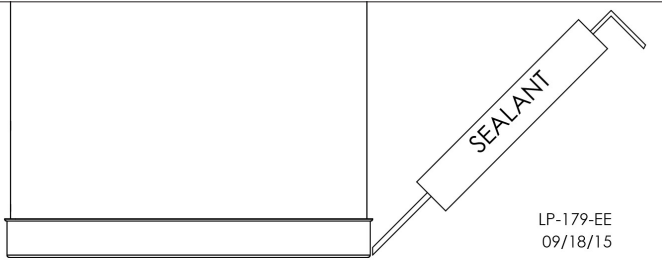

**Sealing Per NSF Standard 5 - For Sanitary Applications**  
Apply a 3/8" bead of RTV Silicone completely around the tank to seal the base to the floor and prevent seepage underneath.

**Figure 32 - Sealing the Water Heater for Sanitary Applications**

**Part 10 - Shutdown**

**A. Shutdown Procedure**

If the burner is not operating, disconnect the electrical supply. If the burner is operating, lower the set point value to 70°F and wait for the burner to shut off. Continue to wait for the combustion blower to stop, so all latent combustion gases are purged from the system. This should take a maximum of 40 to 90 seconds. After combustion gases are purged turn off electrical power to the water heater.

**B. Vacation Procedure**

If there is danger of freezing, change the set point to 70°F. DO NOT turn off electrical power. If there is no danger of freezing, follow "Shutdown Procedure".

**C. Failure to Operate**

Should the burner fail to light, the control will perform two more ignition trials prior to entering a lockout state. Note that each subsequent ignition trial will not occur immediately. After a failed ignition trial, the blower must run for approximately 10 seconds to purge the system. Therefore, a time period of approximately 40 to 90 seconds will expire between each ignition trial.

If the burner lights during any one of these three ignition trials, normal operation will resume. If the burner lights, but goes off in about 4 seconds, check the polarity of the wiring. See electrical connection section of this manual.

If the burner does not light after the third ignition trial, the control will enter a lockout state. This lockout state indicates that a problem exists with the water heater, the controls, or the gas supply. Under such circumstances, a qualified service technician should be contacted immediately to properly service the water heater and correct the problem.

If a technician is not available, pressing the **S4** button will remove the lockout state so additional trials for ignition can be performed. The unit will try to relight once every 6 minutes.

**D. Important Notice**

**NOTICE**

It is extremely important that whenever work is performed on the plumbing system that either:

- The water heater is powered off, or,
- The water heater is valved off and isolated from the plumbing system.

Failure to take these measures could result in a dry-firing condition.

**Resistance Table for Supply Temperature Sensor**

High / Low Temp Sensor Temp. (°F)	Resistance (Ohms)
32	32550
41	25340
50	19870
59	15700
68	12490
77	10000
86	8059
95	6535
104	5330
113	4372
122	3605
131	2989
140	2490
149	2084
158	1753
167	1481
176	1256
185	1070
194	915
202	786
212	667

**Table 18 - Supply Temperature Resistance Sensor**

**WARNING**

The water heater must be full of water and the system fully purged BEFORE powering the water heater. Performing any work in the plumbing system without either powering off the water heater or isolating the water heater through the use of shut-off valves could result in a condition referred to as "dry-firing". Dry-firing the water heater will damage the heat exchanger, and could result in property damage, serious personal injury, or death. Such damages ARE NOT covered by water heater warranty.

## Part 11 - Troubleshooting

### A. Error Code

An error code may occur during installation of the heater. This condition may lead to a lock out condition of the controller, which will need to be manually reset by pressing **S4**. The following information will help the installer correct the problem before going into a lockout condition, which will require a manual reset.

### B. Heater Error

1. When an error condition occurs the controller will display an error code on the display module.
2. These error codes and several suggested corrective actions are included in Table 19.
3. In the case of E00, E13, and E14 error codes, if uncorrected, the water heater will go into a fault condition as described in section C. Lockout.

### C. Lockout

1. When a fault condition occurs, the controller will illuminate the red fault indication light and display a fault code (example: **F00**).
2. Note the fault code and refer to Table 20 for an explanation of the fault code along with several suggestions for corrective actions.
3. Press **S4** to clear the fault and resume operation. Be sure to observe the operation of the unit to prevent a recurrence of the fault.

### CAUTION

The water heater has wire function labels on all internal wiring. Observe the position of each wire before removing it. Wiring errors may cause improper and dangerous operation. Verify proper operation after servicing.

### WARNING

**DO NOT USE THIS APPLIANCE IF ANY PART HAS BEEN SUBMERGED IN WATER.** Immediately call a qualified service technician. The appliance **MUST BE** replaced if it has been submerged. Attempting to operate an appliance that has been submerged could create numerous harmful conditions, such as a potential gas leakage causing a fire and/or explosion, or the release of mold, bacteria, or other harmful particulates into the air. Operating a previously submerged appliance could result in property damage, severe personal injury, or death.  
**NOTE:** Appliance damage due to flood or submersion is considered an Act of God, and **IS NOT** covered under product warranty.

When servicing or replacing any components of this water heater be certain that:

- The gas is off.
- All electrical power is disconnected.

In addition, when servicing or replacing components of this water heater in direct contact with heater water:

- There is no pressure in the heater. Pull the release on the relief valve to relieve pressure in the heater.
- Heater water is not hot.

Failure to follow these precautions could result in property damage, serious personal injury, or death. Such damages **ARE NOT** covered by water heater warranty.

926 Control Board Error Codes

Code	Description	Duration	Corrective Action
<b>E13</b>	Combustion blower speed is less than 70% of expected	60 seconds	1. Check blower wiring. Ensure all wires are plugged in and undamaged. 2. Replace the blower. 3. Replace the control board.
<b>E14</b>	Combustion blower speed is greater than 130% of expected		1. Check blower wiring. Ensure all wires are plugged in and undamaged. 2. Replace the blower. 3. Replace the control board.
<b>LEO</b>	Water level in tank is low	Until corrected	1. Ensure all air is bled from system. 2. Inspect low level switch and wiring for damage and repair if necessary.
<b>FLU</b>	Blocked Vent, Pressure Switch open, Condensate Cup full, Condensate Cup not present		1. Check the flue vent to be sure it is not blocked or damaged. 2. Check blocked vent pressure switch operation by applying a jumper. If the switch is not functioning properly, replace it.
<b>LOU</b>	24 Volt low		1. Check line voltage. Must be between 100 - 128 volts. 2. If available, connect a PC and, using HTP service software, check the 24V supply display in the lower left corner of the screen. The number displayed must be greater than 128 and should be greater than 250. Use this as a troubleshooting guide as you follow the steps below. 3. Remove 10 pin Molex connector from customer connection board. If the <b>LOU</b> code clears, the problem is with external sensor wiring. Examine external sensor wiring for shorts to ground, repairing as necessary. If <b>LOU</b> code is still present and the heater is so equipped, disconnect high gas pressure switch, then low gas pressure switch, then UL 353 low water cutoff in this order, one at a time, to see if <b>LOU</b> code clears. Replace faulty part. Check low voltage wire harness in heater for shorts to ground. 4. If <b>LOU</b> only occurs when burner tries to light, check gas valve for excessive current draw. 5. If <b>LOU</b> is present with the low voltage harness disconnected from the 926 control board, replace the 926 control board.

Table 19 - Error Codes

926 Control Board Fault Codes		
Code	Description	Corrective Action
F00	High temperature switch limit exceeded 194°F	<ol style="list-style-type: none"> <li>1. Try to reset the water heater. If <b>F00</b> repeats, create a demand for hot water. (WARNING: Use caution to prevent burn injury.) If water is above 194°F, test upper and lower temperature sensors with an ohmmeter. (Refer to resistance chart, this section.) Replace bad sensor. If water is below 194°F, test high temperature switch and wiring with ohmmeter. Switch should be closed at this point. If not, replace switch.</li> <li>2. If heater did reset successfully, let the heater run and go into the status menu to check the upper and lower temperature sensors. If either reading displayed does not make sense, check appropriate sensor with ohmmeter. (Refer to resistance chart, Table 18.) Replace bad sensor. Do an OHMs reading on both sensors to check continuity.</li> </ol>
F01	Vent temperature limit exceeded	<ol style="list-style-type: none"> <li>1. Inspect all flue piping. If the flue is damaged or shows signs of overheating, repair or replace the flue parts as necessary before proceeding.</li> <li>2. If the flue piping is intact, undamaged, and there is no sign of the flue overheating (such as discoloration or melting of the flue pipe), push the red reset button on the flue switch.</li> <li>3. Be sure the heater is connected to a water supply and is full of water.</li> <li>4. Push the RESET button on the heater control panel. The water heater should light. If the water heater lights, proceed to step 5. If the water heater does not light and the display again begins to flash <b>F01</b>, inspect the wiring to the flue switch, repairing or replacing as necessary. If the wiring is intact, replace the flue switch, using care to mount the new flue switch in the same position and mounting holes as the old one. If the display flashes a code other than <b>F01</b>, follow the troubleshooting guide for the code.</li> <li>5. Observe operation for 5 minutes. Place the probe of an exhaust analyzer into the flue system within 6 feet of the heater. The exhaust temperature should not rise above 190°F after several minutes of operation.</li> <li>6. If the flue temperature is below 190°F and the heater again goes into lockout displaying <b>F01</b>, replace the flue switch, using care to mount the new flue switch in the same position and mounting holes as the old one. If the display flashes a code other than <b>F01</b>, follow the troubleshooting guide for that code.</li> <li>7. If the flue temperature increases to over 190°F, consult HTP for further assistance.</li> </ol>
F02	Interrupted or shorted upper temperature sensor	<ol style="list-style-type: none"> <li>1. Check the electrical connection to the appropriate temperature sensor.</li> <li>2. If connection is intact, replace the sensor.</li> </ol>
F03	Interrupted or shorted lower temperature sensor	
F05	Upper temp. sensor exceeds 194°F	<ol style="list-style-type: none"> <li>1. If water in tank is less than 194°F, check wiring. Repair if damaged.</li> <li>2. If wiring is intact, check appropriate sensor with ohmmeter and compare to reading in Table 18. If reading does not agree with water temperature, replace the sensor.</li> </ol>
F06	Lower temp. sensor exceeds 194°F	
F09	No flame detected - Heater will make three attempts at ignition before the control goes into this lockout condition. Will reset in 1 hour.	<ol style="list-style-type: none"> <li>1. Watch the igniter through the observation window provided.</li> <li>2. If there is no spark, check the spark electrode for the proper 1/4" gap.</li> <li>3. Remove any corrosion from the spark electrode and flame rectifier probe.</li> <li>4. If there is a spark but no flame, check the gas supply to the heater.</li> <li>5. If there is a flame, check the flame sensor.</li> <li>6. Check for any flue or condensate blockages.</li> </ol>
F10	Loss of flame signal - The heater will attempt to relight four times before the control goes into this condition. Will reset in 1 hour.	<ol style="list-style-type: none"> <li>1. Monitor the gas pressure to the unit while in operation.</li> <li>2. Assure that the flame is stable when lit.</li> <li>3. Check to see if the green light on the display module is out while the heater is running.</li> <li>4. If the green light doesn't come on or goes off during operation check the flame signal on the status menu.</li> <li>5. If the signal reads less than 1 microampere, clean the flame rectifier probe.</li> <li>6. If the flame rectifier probe continues to read low, replace it.</li> </ol>
F11	False flame signal - Occurs if heater senses a flame signal when there should be none present.	<ol style="list-style-type: none"> <li>1. Turn the gas off to the unit as the service valve.</li> <li>2. If the flame signal is still present replace the igniter.</li> <li>3. If the flame signal is not present after turning off the gas supply, check the gas valve electrical connection.</li> <li>4. If there is no power to the gas valve, remove the valve and check for obstruction in the valve seat or replace the gas valve.</li> <li>5. Turn the gas on at the service valve after corrective action is taken.</li> </ol>
F13	Blower speed incorrect - Occurs if blower speed is less than 70% expected for more than 60 seconds.	<ol style="list-style-type: none"> <li>1. Check blower wiring.</li> <li>2. Replace the blower.</li> <li>3. Replace the control board.</li> </ol>

**Table 20 - Fault Codes - NOTE: If you replace a part to remedy a fault, it is recommended that you cycle the water heater at least three or four times to assure the fault has been resolved.**

## Part 12 - Installation Checklist

<b>Before Installing</b>	<b>Yes</b>	<b>No</b>
Is there enough space to ensure proper installation?		
Does installation location allow for proper service clearances?		
Are water and gas lines properly sized and set at proper pressures for the installation?		
Is water heater location as near the exhaust vent / intake pipe terminations as possible?		
Have combustibles materials been cleared from the installation location?		
Is there a drain close to the water heater?		
<b>Water Piping</b>	<b>Yes</b>	<b>No</b>
Does water heater loop piping meet the minimum sizing requirements listed? <b>NOTE:</b> Smaller piping will cause performance problems.		
Has water chemistry been checked?		
Does water chemistry meet requirements?		
If water chemistry does not meet requirements, have treatment measures been put in place?		
Has the system been cleaned and flushed?		
<b>Install Exhaust Vent and Intake Piping</b>	<b>Yes</b>	<b>No</b>
Has the water heater been vented with the approved materials listed in this manual or to meet local codes?		
Is air supply sufficient for proper water heater operation?		
Is total vent piping length within the maximum vent length restriction listed in this manual?		
Have venting lengths been minimized?		
Are terminations properly spaced from windows, doors, and other intake vents?		
Have all vent terminations been installed at least one foot above exterior grade and one foot above normal snow accumulation level?		
Is vent piping properly supported?		
Has vent piping been checked for leaks?		
Has the exhaust vent line been pitched back to the water heater at a rate of 1/4" per foot?		
Have the exhaust vent and intake pipes been properly installed to the water heater?		
<b>Install Condensate Piping / Tubing and Components</b>	<b>Yes</b>	<b>No</b>
Have all condensate components included with the water heater been installed?		
Is the condensate line piped with approved materials listed in this manual?		
Has the condensate line been routed to a laundry tub or other drain?		
<b>Install Gas Piping</b>	<b>Yes</b>	<b>No</b>
Is the gas supply line a minimum of 3/4" in diameter?		
Is the gas supply line length and diameter adequate to deliver the required BTUs?		
Has gas supply line pressure been measured?		
Does the gas type match the type indicated on the water heater rating plate?		
Has a union and shut-off valve been installed?		
<b>Relief Valve</b>	<b>Yes</b>	<b>No</b>
Is the Temperature and Pressure Relief Valve properly installed and discharge line run to open drain?		
Is the discharge line protected from freezing?		
<b>Wiring</b>	<b>Yes</b>	<b>No</b>
Has the power and control been wired per water heater wiring diagram, this manual?		
Is the electrical connection polarity within water heater requirements?		
Does the power supply voltage agree with the water heater rating plate?		
Is the branch circuit wire and fusing or circuit breaker of proper size?		
Are electrical connections tight and properly grounded?		

<b>Start-Up, Adjust, and Test</b>	<b>Yes</b>	<b>No</b>
Has the water heater been started?		
If necessary, has the water heater gas valve been adjusted?		
Has the installation been customized per installation location requirements?		
Have all customized system parameters been tested?		
Has proper water heater operation been confirmed?		
<b>Final Installation Approvals</b>		
<b>Signed by Technician</b>	<b>Date</b>	

**Table 21 - Installation Checklist**

**Part 13 - Maintenance**

**CAUTION**

In unusually dirty or dusty conditions, care must be taken to keep water heater cabinet door in place at all times. Failure to do so **VOIDS** the warranty.

**WARNING**

Allowing the water heater to operate with a dirty combustion chamber will hurt operation. Failure to clean the heat exchanger as needed by the installation location could result in water heater failure, property damage, personal injury, or death. Such product failures **ARE NOT** covered under warranty.

Hydrogen gas can build up in a hot water system served by this water heater that has not been used for a long period of time (generally two weeks or more). When opening a hot water faucet in a system that has been out of use for a time, keep all ignition sources (electrical appliances, open flame, etc.) away from the faucet. If hydrogen is present, there will be a sound of air escaping as water begins to flow. Allow the water to run for a few minutes to dissipate built up hydrogen from the system. Failure to follow these instructions can result in property damage, personal injury, or death.

The water heater requires minimal periodic maintenance under normal conditions. However, in unusually dirty or dusty conditions, periodic vacuuming of the cover to maintain visibility of the display and indicators is recommended.

Periodic maintenance should be performed once a year by a qualified service technician to assure that all the equipment is operating safely and efficiently. The owner should make necessary arrangements with a qualified heating contractor for periodic maintenance of the heater. Installer must also inform the owner that the lack of proper care and maintenance of the heater may result in a hazardous condition.

**NOTICE**

It is extremely important that whenever work is performed on the plumbing system that either:

- The water heater is powered off, or,
- The water heater is valved off and isolated from the plumbing system.

Failure to take these measures could result in a dry-firing condition.

**WARNING**

The water heater must be full of water and the system fully purged **BEFORE** powering the water heater. Performing any work in the plumbing system without either powering off the water heater or isolating the water heater through the use of shut-off valves could result in a condition referred to as “dry-firing”. Dry-firing the water heater will damage the heat exchanger, and could result in property damage, serious personal injury, or death. Such damages **ARE NOT** covered by water heater warranty.

**Considerations**

- To avoid electric shock, disconnect electrical supply before performing maintenance.
- To avoid severe burns, allow the heater to cool before performing maintenance.

**NOTE:** In addition to the routine maintenance detailed in this manual, this water heater should be inspected annually by a qualified service technician to ensure that all the equipment is operating safely and efficiently. The owner should make necessary arrangements with a qualified heating contractor for periodic maintenance of the heater. The installer must also inform the owner that lack of proper care and maintenance may result in a hazardous condition, premature heater failure, and void the warranty.

Routine preventative maintenance ensures the water heater operates safely and efficiently over its service life. The **Owner / User** may perform the maintenance activities described below.

**Monthly (Every two weeks in hard water locations)**

It is recommended that a few quarts of water be drained from the heater. This will flush sediment deposits from the bottom of the heater and lengthen the heater’s service life.

**WARNING**

Water drained from the water heater may be scalding hot. Take care to avoid scalding. Wear gloves and safety glasses, and direct water to a safe drainage location. It is recommended to turn down the water heater thermostat and run hot water from a faucet until it cools **BEFORE** draining water from the heater. Failure to comply with this warning could result in property damage, severe personal injury, or death.

To flush the tank, attach a hose to the water heater drain valve. Open the drain valve. Direct the flow of water to a drain or bucket where it will not cause damage.

Flush until water runs clear to complete this operation. Then close the drain valve.

**Periodically (At least twice a year)**

Check around the water heater and related plumbing for leaks. If the combination temperature and pressure relief valve discharges periodically, or water is leaking from the water heater, there may be a problem with your water system. DO NOT ATTEMPT TO REPAIR LEAKS YOURSELF! Contact a qualified service contractor for assistance.

Check the area around the water heater for flammable liquids or combustible materials. If any are found, remove from the area.

**Vacation (Extended shut-off periods)**

During extended mild or warm weather periods when hot water will not be in use, lower the setpoint temperature on the water heater. When hot water is needed again, raise the setpoint temperature on the water heater.

Drain the water heating system (as detailed in this section) if the water heater will be shut off and exposed to freezing temperatures.

Fill the water heating system (as detailed in this section) when hot water is needed again. Contact a qualified service contractor for assistance if necessary.

**Draining the Water Heater**

**STEP #1** - Turn off power to the water heating system, preferably at the circuit breaker.

 <b>WARNING</b>
Failure to cut power off to the water heating system before draining may result in property damage, severe personal injury, or death due to electric shock.

**STEP #2** - Run hot water at a faucet in the system. When it runs cold, shut off the faucet. Then shut off water at the main cold water inlet or, if possible, valve off the water heater from the system.

**STEP #3** - Open the T&P valve or a hot water tap to prevent vacuum buildup in the tank and piping. Then open the drain valve on the water heater to drain the water from the isolated water heater or water heating system.

**STEP #4** - Close the valve(s) and faucet after the water is drained.

**To Fill the Water Heater and System:**

**STEP #1** - Open a hot water tap high in the system to bleed any air pressure. Water will flow freely when air is completely bled.

 <b>WARNING</b>
When filling the water heater, open a hot water tap to release air in the tank and piping. The tank must be full of water before the heater is turned on. Failure to ensure the water heater is full before turning it on will result in damage to the water heater, and could result in property damage, serious personal injury, or death. Such damages ARE NOT covered by water heater warranty.

**STEP #2** - Open the main cold water inlet. If the water heater has been isolated from the system, open the isolation valves. Refill the tank with cold water.

**STEP #3** - Close the tap when air is completely bled from the system and water is flowing freely. Check the water heater and system for leaks.

**STEP #4** - Turn power back on to the domestic water heating system and observe operation. Ensure the water heater is operating properly.

The maintenance activities described below are only to be performed by the **Installer / Qualified Service Provider**. These maintenance items should be performed during recommended **annual** service and any service calls.

1. Ask the owner / user if there have been any issues with the water heater. Diagnose any heater issues and repair / replace parts as necessary.
2. Check the water heater and related plumbing for leaks. Repair any that are found.
3. Check the area around the water heater for flammable liquids or combustible materials. If any are found, remove from the area.
4. Remove and inspect the anode. Replace if necessary.
5. Inspect the Temperature and Pressure (T&P) Relief Valve. See instructions, this manual.
6. Turn power supply off to the water heater. Open the drain valve and drain a few gallons of water from the tank to clear any hard water deposits. Once complete, close the drain valve and restore power to the water heater.

**To Inspect / Replace the Anode**

**STEP #1** - Drain the water heater following the procedure detailed in this section.

 <b>WARNING</b>
Completely drain the water heater before removing the anode. Failure to do so will result in a leakage of water and property damage, and could possibly result in moderate to severe personal injury or death.

**STEP #2** - After the water heater is drained remove the anode rod. Anode rod location and size is detailed in Replacement Parts, this manual.

**STEP #3** - Observe the anode rod. The anode rod should be replaced when more than 6" of core wire is exposed at either end of the rod.

**STEP #4** - Use pipe tape or approved sealant on threads to install the anode rod. Fill the water heater and check for leaks.

Inspection Activities		Date Last Completed			
Piping		1st Year	2nd Year	3rd Year	4th Year*
Near heater piping	Check heater and system piping for any sign of leakage; make sure pipes are properly supported.				
Vent	Check condition of all vent pipes and joints. Ensure the vent piping terminations are free of obstructions and blockages.				
Gas	Check gas piping. Test for leaks and signs of aging. Make sure all pipes are properly supported.				
System		1st Year	2nd Year	3rd Year	4th Year*
Visual	Do a full visual inspection of all system components.				
Functional	Test all functions of the system (Heat, Safeties).				
Temperatures	Verify safe settings on heater or anti-scald valve.				
	Verify programmed temperature settings.				
Electrical					
Connections	Check wire connections. Make sure connections are tight.				
Smoke and CO Detector	Verify devices are installed and working properly. Change batteries if necessary.				
Circuit Breakers	Check to see that the circuit breaker is clearly labeled. Exercise circuit breaker.				
Anode Rod		1st Year	2nd Year	3rd Year	4th Year*
	At least annually - Remove and visually inspect the anode rod. Anode rod should be replaced when more than 6" of core wire is exposed at either end of the rod.				
Chamber / Burner		1st Year	2nd Year	3rd Year	4th Year*
Combustion Chamber	Check burner tube and combustion chamber coils. Clean according to maintenance section of manual. Vacuum combustion chamber. Replace any gaskets that show signs of damage.				
Spark Electrode	Clean. Set gap at 1/4" Clean probe with plumbers cloth to remove oxides.				
Combination Ignitor and Flame Probe	Check ionization in uA (d7 in Status Menu in Start-Up Procedures). Record high fire and low fire. Clean probe with plumbers cloth to remove oxides.				
Condensate		1st Year	2nd Year	3rd Year	4th Year*
Neutralizer	Check condensate neutralizer. Replace if necessary.				
Condensate Pipe	Disconnect condensate pipe. Clean out dirt. Fill with water to level of outlet and reinstall. (NOTE: Verify the flow of condensate, making sure that the hose is properly connected during final inspection.)				
Gas		1st Year	2nd Year	3rd Year	4th Year*
Pressure	Measure incoming gas pressure (3.5" to 10" WC for Natural Gas, 8" to 14" WC for Propane).				
Pressure Drop	Measure drop in pressure on light off (no more than 1" WC).				
Check Gas Pipe for Leaks	Check piping for leaks. Verify that all are properly supported.				
Combustion		1st Year	2nd Year	3rd Year	4th Year*
CO / CO2 Levels	Check CO and CO2 levels in exhaust. See Start-Up Procedures for ranges. Record at high and low fire.				
Safeties		1st Year	2nd Year	3rd Year	4th Year*
ECO (Energy Cut Out)	Check continuity on flue and water ECO. Replace if corroded.				
Sensors	Check wiring. Verify through ohms reading.				
Final Inspection		1st Year	2nd Year	3rd Year	4th Year*
Check List	Verify that you have completed entire check list. WARNING: FAILURE TO DO SO COULD RESULT IN SERIOUS INJURY OR DEATH.				
Homeowner	Review what you have done with the homeowner.				

Table 22 - \*Continue annual maintenance beyond the 4th year as required.

Part 14 - Replacement Parts

LP-179-J  
03/04/22

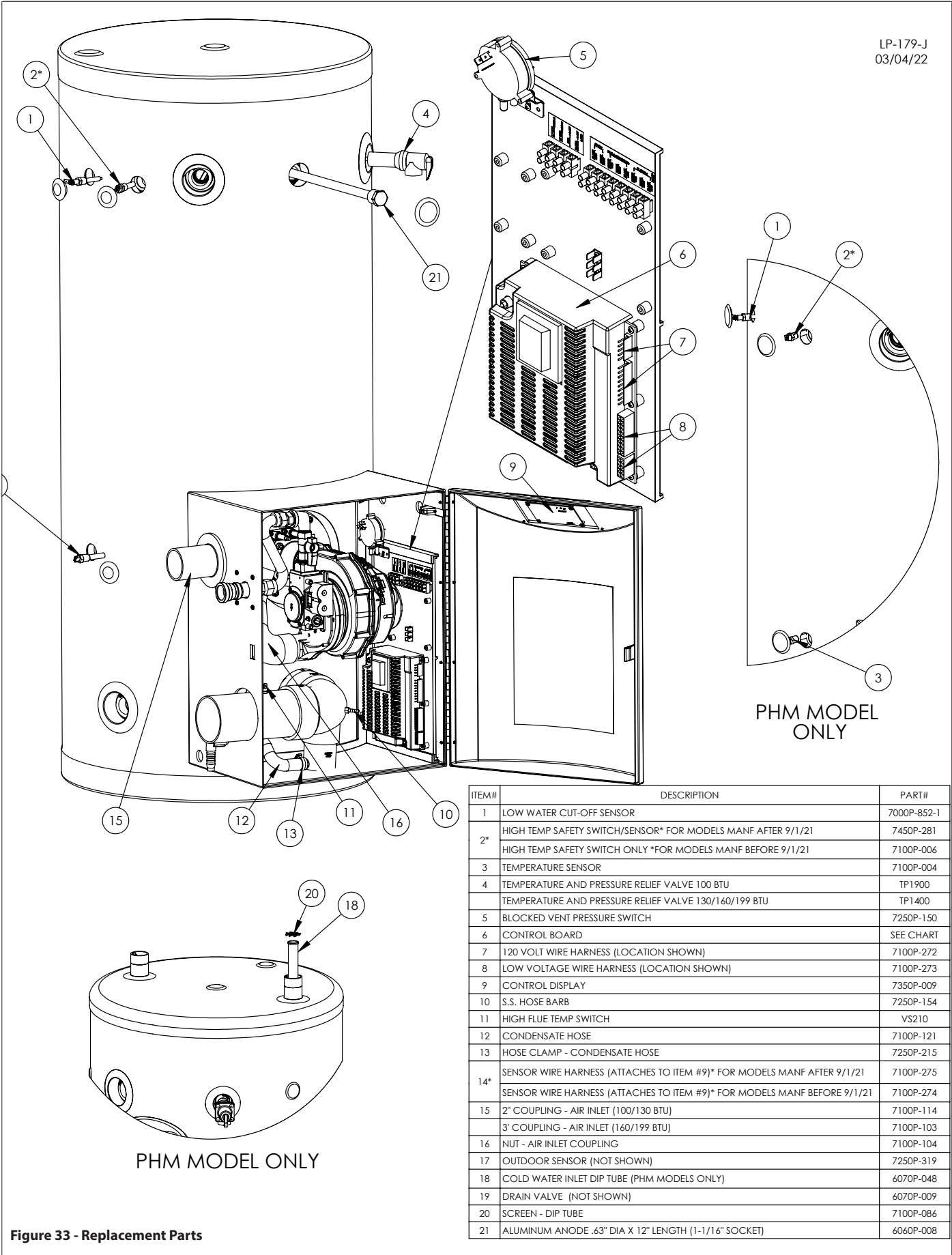

ITEM#	DESCRIPTION	PART#
1	LOW WATER CUT-OFF SENSOR	7000P-852-1
2*	HIGH TEMP SAFETY SWITCH/SENSOR* FOR MODELS MANF AFTER 9/1/21	7450P-281
	HIGH TEMP SAFETY SWITCH ONLY *FOR MODELS MANF BEFORE 9/1/21	7100P-006
3	TEMPERATURE SENSOR	7100P-004
4	TEMPERATURE AND PRESSURE RELIEF VALVE 100 BTU	TP1900
	TEMPERATURE AND PRESSURE RELIEF VALVE 130/160/199 BTU	TP1400
5	BLOCKED VENT PRESSURE SWITCH	7250P-150
6	CONTROL BOARD	SEE CHART
7	120 VOLT WIRE HARNESS (LOCATION SHOWN)	7100P-272
8	LOW VOLTAGE WIRE HARNESS (LOCATION SHOWN)	7100P-273
9	CONTROL DISPLAY	7350P-009
10	S.S. HOSE BARB	7250P-154
11	HIGH FLUE TEMP SWITCH	VS210
12	CONDENSATE HOSE	7100P-121
13	HOSE CLAMP - CONDENSATE HOSE	7250P-215
14*	SENSOR WIRE HARNESS (ATTACHES TO ITEM #9)* FOR MODELS MANF AFTER 9/1/21	7100P-275
	SENSOR WIRE HARNESS (ATTACHES TO ITEM #9)* FOR MODELS MANF BEFORE 9/1/21	7100P-274
15	2" COUPLING - AIR INLET (100/130 BTU)	7100P-114
	3" COUPLING - AIR INLET (160/199 BTU)	7100P-103
16	NUT - AIR INLET COUPLING	7100P-104
17	OUTDOOR SENSOR (NOT SHOWN)	7250P-319
18	COLD WATER INLET DIP TUBE (PHM MODELS ONLY)	6070P-048
19	DRAIN VALVE (NOT SHOWN)	6070P-009
20	SCREEN - DIP TUBE	7100P-086
21	ALUMINUM ANODE .63" DIA X 12" LENGTH (1-1/16" SOCKET)	6060P-008

Figure 33 - Replacement Parts

LP-179-H  
12/6/21

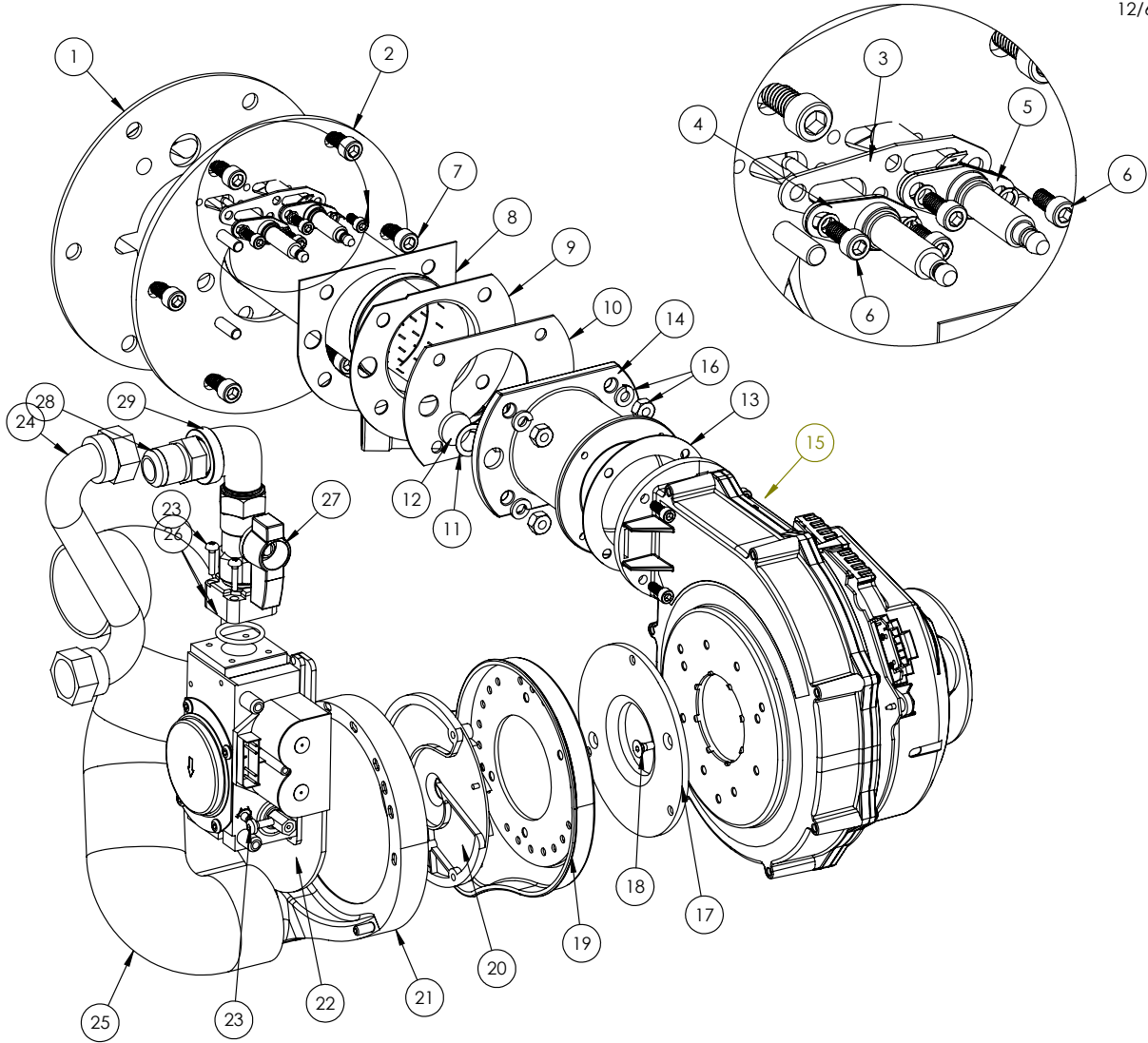

ITEM#	DESCRIPTION	PART#
1	GASKET - MOUNTING PLATE	7100P-139
2	MOUNTING PLATE	7100P-007
3	GASKET - PROBES	7100P-155
4	FLAME RECTIFICATION PROBE (w/GASKET)	7100P-082
5	IGNITOR ELECTRODE (w/GASKET)	7100P-124
6	10-32 X 3/8 SCREWS/#10 LOCK WASHERS	N/A
7	5/16-18 x 5/8" SOCKET CAP SCREW	7700P-101
8	GASKET - BURNER MOUNTING FLANGE	7100P-152
9	BURNER - 100-130K BTU	7100P-516
	BURNER - 160-199K BTU	7100P-517
10	GASKET - BURNER OUTLET	7000P-361
11	GASKET - SIGHT GLASS	7100P-105
12	SIGHT GLASS	G2000
13	GASKET - AIR CHANNEL	7500P-075
14	AIR CHANNEL	7700P-003
15	COMBUSTION BLOWER (ALL BTU'S)	7100P-330

ITEM#	DESCRIPTION	PART#
16	1/4-20 BRASS NUTS/1/4 LOCK WASHERS	7100P-268
17	ADAPTER PLATE	7250P-644
18	SCREW - ADAPTER PLATE	7100P-045
19	AIR INTAKE ADAPTER - BLOWER SIDE	7500P-184
20	SWIRL PLATE - BLACK (100/130 BTU)	7100P-042
	SWIRL PLATE - WHITE (160/199 BTU)	7500P-092
21	AIR INTAKE ADAPTER - VALVE SIDE	7500P-185
22	GAS VALVE (100/130 BTU)	7000P-862
	GAS VALVE (160/199 BTU)	7000P-863
23	SCREWS	7250P-717
24	1/2" FLARE X 1/2" NPT FLEX HOSE	7100P-140
25	TUBE - AIR INLET	7500P-189
26	GAS VALVE ADAPTER (w/O-RING)	7250P-454
27	GAS SHUT-OFF VALVE	7250P-140
28	1/2" FLARE X 1/2" NPT FITTING	7450P-154
29	1/2" MALE X FEMALE BLACK 90 DEGREE ELBOW	7250P-693

Figure 34 - Replacement Parts - Combustion System

<b>Model</b>	<b>Control Board Part Numbers</b>	<b>Model</b>	<b>Control Board Part Numbers</b>
100kBTU 55 Gal	7100P-1100	Solar 130kBTU 80/119 Gal	7100P-1112
130kBTU 55 Gal	7100P-1101	Solar 199kBTU 80/119 Gal	7100P-1113
160kBTU 55 Gal	7100P-1102	Sanitizer 130kBTU 55 Gal	7100P-1115
199kBTU 55 Gal	7100P-1103	Sanitizer 199kBTU 55 Gal	7100P-1114
100kBTU 80 Gal	7100P-1104	HiTemp 199kBTU 80 Gal	7100P-1117
130kBTU 80 Gal	7100P-1105	HiTemp 199kBTU 119 Gal	7100P-1116
160kBTU 80 Gal	7100P-1106		
199kBTU 80 Gal	7100P-1107		
100kBTU 119 Gal	7100P-1108		
130kBTU 119 Gal	7100P-1109		
160kBTU 119 Gal	7100P-1110		
199kBTU 119 Gal	7100P-1111		

**Table 23 - Control Board Replacement Part Numbers**

**Phoenix® Gas Water Heater and Solar Gas Water Heater  
Limited Warranty  
For Residential and Commercial Use**

HTP warrants this water heater and its components to be free from defects in material and workmanship according to the following terms, conditions, and time periods. UNLESS OTHERWISE NOTED THESE WARRANTIES COMMENCE ON THE DATE OF INSTALLATION. This limited warranty is only available to the **original consumer purchaser** (hereinafter "Owner") of this water heater, and is non-transferable.

<p><b>Residential Use Warranty (Seven (7) years – Tank, One (1) year – Parts)</b></p>
<p>Residential Use shall mean water heater usage in a single family dwelling, or usage in a multiple family dwelling, provided the water heater services only one (1) dwelling <b>in which the Owner resides on a permanent basis and operating temperatures do not exceed 140°F.</b></p>
<p><b>Commercial Use Warranty (Three (3) years – Tank, One (1) year – Parts)</b></p>
<p>Standard Commercial Use shall mean any usage not falling within the definition of a "residential" setting.</p>

**COVERAGE**

- A. During the first year after the original date of installation, HTP warrants that it will repair or replace, at its option, any defective or malfunctioning component of the water heater with a component of equivalent size and current model. Replacement components will be warranted for ninety (90) days.
- B. Should a defect or malfunction result in a leakage of water from the water heater within the above-stated warranty periods due to defective material or workmanship, malfunction, or failure to comply with the above warranty, with such defect or malfunction having been verified by an authorized HTP representative, HTP will replace the defective or malfunctioning water heater with a replacement of the nearest comparable model available at the time of replacement. The replacement water heater will be warranted for the unexpired portion of the applicable warranty period of the original water heater.
- C. In the event of a leakage of water of a replacement water heater due to defective material or workmanship, malfunction, or failure to comply with the above warranty, HTP reserves the right to refund to the Owner the published wholesale price available at the date of manufacture of the original water heater.
- D. If government regulations, industry certification, or similar standards require the replacement water heater or component(s) to have features not found in the defective water heater or component(s), the Owner will be charged the difference in price represented by those required features. If the Owner pays the price difference for those required features and/or to upgrade the size and/or other features available on a new replacement water heater or component(s), the Owner will also receive a complete new limited warranty for that replacement water heater or component(s).
- E. If at the time of a request for service the Owner cannot provide a copy of the original sales receipt or the warranty registration, the warranty period for the water heater shall then be deemed to have commenced thirty (30) days after the date of manufacture of the water heater and NOT the date of installation of the water heater.
- F. This warranty extends only to water heaters utilized in water heating applications that have been properly installed by qualified professionals based upon the manufacturer's installation instructions.
- G. It is expressly agreed between HTP and the Owner that repair, replacement, or refund are the exclusive remedies of the Owner.

**OWNER RESPONSIBILITIES**

The Owner or Qualified Installer / Service Technician must:

1. Have a relief valve bearing the listing marks of the American Society of Mechanical Engineers (ASME) installed with the water heater assembly in accordance with federal, state, and local codes.
2. Have a vacuum relief valve certified to ANSI Z21.22 - Relief Valves for Hot Water Supply Systems installed with the water heater assembly in accordance with federal, state, and local codes and in installations prone to vacuum related damages.
3. Maintain the water heater in accordance with the maintenance procedure listed in the manufacturer's provided instructions. Preventive maintenance can help avoid any unnecessary breakdown of the water heater and keep it running at optimum efficiency.
4. Maintain all related system components in good operating condition.
5. Use the water heater in an open system, or in a closed system with a properly sized and installed thermal expansion tank.
6. Use the water heater at water pressures not exceeding the working pressure shown on the rating plate.
7. Keep the water heater free of damaging scale deposits.
8. Make provisions so if the water heater or any component or connection thereto should leak, the resulting flow of water will not cause damage to the area in which it is installed.
9. Have the anode rods inspected and replaced as necessary.

**WARRANTY EXCLUSIONS**

This limited warranty will not cover:

1. Any water heater purchased from an unauthorized dealer.
2. Any water heater not installed by a qualified installer / service technician, or installations that do not conform to ANSI, CSA, and/or UL standards, as well as any applicable national or local building codes.
3. Service trips to teach the Owner how to install, use, maintain, or to bring the water heater installation into compliance with local building codes and regulations.
4. The workmanship of any installer. The manufacturer disclaims and does not assume any liability of any nature caused by improper installation, repair, or maintenance.
5. Electricity or fuel costs, or increased or unrealized savings for same, for any reason whatsoever.
6. Any water damage arising, directly or indirectly, from any defect in the water heater or component part(s) or from its use.
7. Any incidental, consequential, special, or contingent damages or expenses arising, directly or indirectly, from any defect in the water heater or the use of the water heater.
8. Failure to locate the water heater in an area where leakage of the tank or water line connections and the relief valve will not result in damage to the area adjacent to the water heater or lower floors of the structure, as well as failure to install the water heater in or with a properly sized drain pan routed to an approved drainage location.
9. Any failed components of the system not manufactured by HTP as part of the water heater.
10. Water heaters repaired or altered without the prior written approval of HTP.
11. Damages, malfunctions, or failures resulting from failure to install the water heater in accordance with applicable building codes/ordinances or good plumbing and electrical trade practices.
12. Damages, malfunctions, or failures resulting from improper installation, failure to operate the water heater at firing rates or pressures not exceeding those on the rating plate, or failure to operate and maintain the water heater in accordance with the manufacturer's provided instructions.
13. Failure to operate the water heater in a an open system, or in a closed system with a properly sized and installed thermal expansion tank.
14. Failure or performance problems caused by improper sizing of the water heater, expansion device, piping, or the gas supply line,

the venting connection, combustion air openings, electric service voltage, wiring or fusing.

15. Damages, malfunctions, or failures caused by improper conversion from natural gas to LP gas or LP gas to natural gas.

16. Damages, malfunctions, or failures caused by operating the water heater with modified, altered, or unapproved components, or any component / attachment not supplied by HTP.

17. Damages, malfunctions, or failures caused by abuse, accident, fire, flood, freeze, lightning, electrochemical reaction, acts of God and the like.

18. Failures (leaks) caused by operating the water heater in a corrosive or contaminated atmosphere.

19. Damages, malfunctions, or failures caused by operating an empty or partially empty water heater ("dry firing"), or failures caused by operating the water heater when it is not supplied with water, free to circulate at all times.

20. Any damage or failure of the water heater due to the accumulation of solid materials or lime deposits.

21. Any damage or failure resulting from improper water chemistry. WATER CHEMISTRY REQUIREMENTS (RESIDENTIAL USE) – Water pH between 6.5 and 8.5. Operating temperatures not exceeding 140°F. Hardness less than 12 grains (200 mg/L). Chloride concentration less than 100 ppm (mg/L). TDS less than 500 ppm (mg/L). (COMMERCIAL USE) - Water pH between 6.5 and 8.5. Hardness less than 7 grains (120 mg/L). Chloride concentration less than 100 ppm (mg/L). TDS less than 500 ppm (mg/L).

22. Any damages, malfunctions, or failures resulting from the use of dielectric unions.

23. Water heaters replaced for cosmetic reasons.

24. Components of the water heater that are not defective, but must be replaced during the warranty period as a result of reasonable wear and tear.

25. Components of the water heater that are subject to warranties, if any, given by their manufacturers; HTP does not adopt these warranties.

26. Damages, malfunctions, or failures resulting from the use of any attachment(s) not supplied by HTP.

27. Any damages, malfunctions, or failures resulting from removal of the anode rods, or failure to inspect and replace the anode rods as necessary.

28. Water heaters installed outside the fifty states (and the District of Columbia) of the United States of America and Canada.

29. Water heaters moved from the original installation location.

30. Water heaters that have had their rating labels removed.

#### PROCEDURES FOR WARRANTY SERVICE REQUESTS

Any claim for warranty assistance must be made immediately upon finding the issue. First, please consult the HTP Warranty Wizard (<http://www.htproducts.com/Warranty-Wizard.html>) to check warranty eligibility. You may also contact HTP Technical Support at 1-800-323-9651 for questions or assistance. Warranty coverage requires review and approval of the issue with HTP Technical Support or through the Warranty Wizard prior to a full unit replacement. Any claim for warranty reimbursement will be rejected if prior approval from HTP is not obtained in advance of a full unit replacement. Final determination will be made as part of the warranty claim process.

**When submitting a warranty claim the following items are required:**

**1. Proof of purchase or installation of the product** – Typically a copy of the invoice from the installing contractor, the receipt of the purchase of the product, or an original certificate of occupancy for a new home.

**2. Clear pictures (or video) of the following:**

- a. Serial number tag (sticker)
- b. The product
- c. The product issue / failure whenever possible
- d. A picture of the piping near the product
- e. For gas fired products, a picture of the venting, including how it exits the building

All claims will be reviewed by HTP within three (3) business days. If

additional information is required and requested by the HTP Claims Department you will have thirty (30) days to provide it. When all requested information is provided HTP will respond within three (3) business days. The claim will be automatically closed if requested information is not provided within thirty (30) days. Claims will not be reopened without HTP Warranty Supervisor approval.

During the claims process a product that must be replaced will be given a designation of either a) field scrap, or b) return to HTP. If the product must be returned to HTP, the returned product must arrive at HTP within thirty (30) days of the date of our request to return the product. After receipt of the returned product HTP may require as many as thirty (30) additional days for product testing. **NOTE: Any components or heaters returned to HTP for warranty analysis will become the property of HTP and will not be returned, even if credit is denied.**

If you have questions about the coverage of this warranty, please contact HTP at the following address or phone number: HTP, 272 Duchaine Blvd., New Bedford, MA, 02745, Attention: Warranty Service Department, 1(800) 323-9651.

#### SERVICE, LABOR, AND SHIPPING COSTS

Except when specifically prohibited by the applicable state law, the Owner, and not the Manufacturer, shall be liable for and shall pay for all charges for labor or other expenses incurred in the removal, repair, or replacement of the water heater or any component part(s) claimed to be defective or any expense incurred to remedy any defect in the product. Such charges include, but are not necessarily limited to:

1. All freight, shipping, handling, and delivery costs of forwarding a new water heater or replacement part(s) to the owner.
2. All costs necessary or incidental in removing the defective water heater or component part(s) and installing a new water heater or replacement part(s).
3. All administrative fees incurred by the Owner, as well as material required to complete, and/or permits required for, installation of a new water heater or replacement part(s), and
4. All costs necessary or incidental in returning the defective water heater or component part(s) to a location designated by the manufacturer.

#### LIMITATIONS OF YOUR HTP WARRANTY AND REMEDIES

**THE FOREGOING WARRANTIES ARE EXCLUSIVE AND ARE GIVEN AND ACCEPTED TO THE FURTHEST EXTENT UNDER APPLICABLE LAW IN LIEU OF ANY AND ALL OTHER WARRANTIES, EXPRESS OR IMPLIED, INCLUDING WITHOUT LIMITATION THE IMPLIED WARRANTIES OF MERCHANTABILITY AND FITNESS FOR A PARTICULAR PURPOSE AND ANY OBLIGATION, LIABILITY, RIGHT, CLAIM OR REMEDY IN CONTRACT OR TORT, WHETHER OR NOT ARISING FROM HTP'S NEGLIGENCE, ACTUAL OR IMPUTED. THE REMEDIES OF THE OWNER SHALL BE LIMITED TO THOSE PROVIDED HEREIN TO THE EXCLUSION OF ANY OTHER REMEDIES INCLUDING WITHOUT LIMITATION, INCIDENTAL OR CONSEQUENTIAL DAMAGES, SAID INCIDENTAL AND CONSEQUENTIAL DAMAGES INCLUDING, BUT NOT LIMITED TO, PROPERTY DAMAGE, LOST PROFIT OR DAMAGES ALLEGED TO HAVE BEEN CAUSED BY ANY FAILURE OF HTP TO MEET ANY OBLIGATION UNDER THIS AGREEMENT INCLUDING THE OBLIGATION TO REPAIR AND REPLACE SET FORTH ABOVE. NO AGREEMENT VARYING OR EXTENDING THE FOREGOING WARRANTIES, REMEDIES OR THIS LIMITATION WILL BE BINDING UPON HTP. UNLESS IN WRITING AND SIGNED BY A DULY AUTHORIZED OFFICER OF HTP. THE WARRANTIES STATED HEREIN ARE NOT TRANSFERABLE AND SHALL BE FOR THE BENEFIT OF THE ORIGINAL OWNER ONLY.**

#### NO OTHER WARRANTIES

This warranty gives the Owner specific legal rights. The Owner may also have other rights that vary from state to state. Some states do not allow the exclusion or limitation of incidental or consequential damages so this limitation or exclusion may not apply to the Owner. These are the only written warranties applicable to this water heater manufactured and sold by HTP. HTP neither assumes nor authorizes anyone to assume for it any other obligation or liability in connection with said water heaters. HTP reserves the right to change specifications or discontinue models without notice.

**Phoenix® and Phoenix® Multi-Fit Gas Water Heater  
Massachusetts Supplemental Commercial Use Warranty  
For Multiple Water Heater Installations**

When properly registered by an HTP sales representative, HTP will warrant a minimum of two (2) to a maximum of four (4) Phoenix® or Phoenix® Multi-Fit units installed in a Reverse Manifold Piping Installation in the State of Massachusetts to be free from defects in materials and workmanship according to the following terms, conditions, and stated time periods. UNLESS OTHERWISE NOTED THESE WARRANTIES COMMENCE ON THE DATE OF INSTALLATION. This limited warranty is only available to the **original consumer purchaser** (hereinafter "Owner") of the water heater, and is non-transferable.

**Massachusetts Supplemental Commercial Use Warranty  
For Multiple Water Heater Installations  
(Ten [10] years – Tank, One [1] year – Parts)**

**COVERAGE**

- A. This warranty extends only to installations of a minimum of two (2) to a maximum of four (4) Phoenix® and Phoenix® Multi-Fit Gas Water Heaters utilized in reverse manifold piping commercial applications in the State of Massachusetts that have been properly installed by qualified professionals based upon the manufacturer's installation instructions.
- B. During the first year after the original date of installation, HTP warrants that it will repair or replace, at its option, any defective or malfunctioning component of the water heater with a component of equivalent size and current model. Replacement components will be warranted for ninety (90) days.
- C. Should a defect or malfunction result in a leakage of water from the water heater within the above-stated warranty periods due to defective material or workmanship, malfunction, or failure to comply with the above warranty, with such defect or malfunction having been verified by an authorized HTP representative, HTP will replace the defective or malfunctioning water heater with a replacement of the nearest comparable model available at the time of replacement. The replacement water heater will be warranted for the unexpired portion of the applicable warranty period of the original water heater.
- D. In the event of a leakage of water of a replacement water heater due to defective material or workmanship, malfunction, or failure to comply with the above warranty, HTP reserves the right to refund to the Owner the published wholesale price available at the date of manufacture of the original water heater.
- E. If government regulations, industry certification, or similar standards require the replacement water heater or component(s) to have features not found in the defective water heater or component(s), the Owner will be charged the difference in price represented by those required features. If the Owner pays the price difference for those required features and/or to upgrade the size and/or other features available on a new replacement water heater or component(s), the Owner will also receive a complete new limited warranty for that replacement water heater or component(s).
- F. If at the time of a request for service the Owner cannot provide a copy of the original sales receipt or the warranty registration, the warranty period for the water heater shall then be deemed to have commenced thirty (30) days after the date of manufacture of the water heater and NOT the date of installation of the water heater.
- G. This warranty extends only to water heaters utilized in water heating applications that have been properly installed by qualified professionals based upon the manufacturer's installation instructions.
- H. It is expressly agreed between HTP and the Owner that repair, replacement, or refund are the exclusive remedies of the Owner.

**OWNER RESPONSIBILITIES**

The Owner or Qualified Installer / Service Technician must:

1. Have a relief valve bearing the listing marks of the American Society of Mechanical Engineers (ASME) installed with the water heater assembly in accordance with federal, state, and local codes.
2. Have a vacuum relief valve certified to ANSI Z21.22 - Relief Valves for Hot Water Supply Systems installed with the water heater assembly in accordance with federal, state, and local codes and in installations prone to vacuum related damages.
3. Maintain the water heater in accordance with the maintenance procedure listed in the manufacturer's provided instructions. Preventive maintenance can help avoid any unnecessary breakdown of the water heater and keep it running at optimum efficiency.
4. Maintain all related system components in good operating condition.
5. Use the water heater in an open system, or in a closed system with a properly sized and installed thermal expansion tank.
6. Use the water heater at water pressures not exceeding the working pressure shown on the rating plate.
7. Keep the water heater free of damaging scale deposits.
8. Make provisions so if the water heater or any component or connection thereto should leak, the resulting flow of water will not cause damage to the area in which it is installed.
9. Have the anode rods inspected and replaced as necessary.

**WARRANTY EXCLUSIONS**

This limited warranty will not cover:

1. Any water heater purchased from an unauthorized dealer.
2. Any water heater not installed by a qualified installer / service technician, or installations that do not conform to ANSI, CSA, and/or UL standards, as well as any applicable national or local building codes.
3. Service trips to teach the Owner how to install, use, maintain, or to bring the water heater installation into compliance with local building codes and regulations.
4. The workmanship of any installer. The manufacturer disclaims and does not assume any liability of any nature caused by improper installation, repair, or maintenance.
5. Electricity or fuel costs, or increased or unrealized savings for same, for any reason whatsoever.
6. Any water damage arising, directly or indirectly, from any defect in the water heater or component part(s) or from its use.
7. Any incidental, consequential, special, or contingent damages or expenses arising, directly or indirectly, from any defect in the water heater or the use of the water heater.
8. Failure to locate the water heater in an area where leakage of the tank or water line connections and the relief valve will not result in damage to the area adjacent to the water heater or lower floors of the structure, as well as failure to install the water heater in or with a properly sized drain pan routed to an approved drainage location.
9. Any failed components of the system not manufactured by HTP as part of the water heater.
10. Water heaters repaired or altered without the prior written approval of HTP.
11. Damages, malfunctions, or failures resulting from failure to install the water heater in accordance with applicable building codes/ordinances or good plumbing and electrical trade practices.
12. Damages, malfunctions, or failures resulting from improper installation, failure to operate the water heater at firing rates or pressures not exceeding those on the rating plate, or failure to operate and maintain the water heater in accordance with the manufacturer's provided instructions.
13. Failure to operate the water heater in a an open system, or in a closed system with a properly sized and installed thermal expansion tank.
14. Failure or performance problems caused by improper sizing of the water heater, expansion device, piping, or the gas supply line,

the venting connection, combustion air openings, electric service voltage, wiring or fusing.

15. Damages, malfunctions, or failures caused by improper conversion from natural gas to LP gas or LP gas to natural gas.

16. Damages, malfunctions, or failures caused by operating the water heater with modified, altered, or unapproved components, or any component / attachment not supplied by HTP.

17. Damages, malfunctions, or failures caused by abuse, accident, fire, flood, freeze, lightning, electrochemical reaction, acts of God and the like.

18. Failures (leaks) caused by operating the water heater in a corrosive or contaminated atmosphere.

19. Damages, malfunctions, or failures caused by operating an empty or partially empty water heater ("dry firing"), or failures caused by operating the water heater when it is not supplied with water, free to circulate at all times.

20. Any damage or failure of the water heater due to the accumulation of solid materials or lime deposits.

21. Any damage or failure resulting from improper water chemistry. WATER CHEMISTRY REQUIREMENTS (RESIDENTIAL USE) – Water pH between 6.5 and 8.5. Operating temperatures not exceeding 140°F. Hardness less than 12 grains (200 mg/L). Chloride concentration less than 100 ppm (mg/L). TDS less than 500 ppm (mg/L). (COMMERCIAL USE) - Water pH between 6.5 and 8.5. Hardness less than 7 grains (120 mg/L). Chloride concentration less than 100 ppm (mg/L). TDS less than 500 ppm (mg/L).

22. Any damages, malfunctions, or failures resulting from the use of dielectric unions.

23. Water heaters replaced for cosmetic reasons.

24. Components of the water heater that are not defective, but must be replaced during the warranty period as a result of reasonable wear and tear.

25. Components of the water heater that are subject to warranties, if any, given by their manufacturers; HTP does not adopt these warranties.

26. Damages, malfunctions, or failures resulting from the use of any attachment(s) not supplied by HTP.

27. Any damages, malfunctions, or failures resulting from removal of the anode rods, or failure to inspect and replace the anode rods as necessary.

28. Water heaters installed outside the fifty states (and the District of Columbia) of the United States of America and Canada.

29. Water heaters moved from the original installation location.

30. Water heaters that have had their rating labels removed.

#### PROCEDURES FOR WARRANTY SERVICE REQUESTS

Any claim for warranty assistance must be made immediately upon finding the issue. First, please consult the HTP Warranty Wizard (<http://www.htproducts.com/Warranty-Wizard.html>) to check warranty eligibility. You may also contact HTP Technical Support at 1-800-323-9651 for questions or assistance. Warranty coverage requires review and approval of the issue with HTP Technical Support or through the Warranty Wizard prior to a full unit replacement. Any claim for warranty reimbursement will be rejected if prior approval from HTP is not obtained in advance of a full unit replacement. Final determination will be made as part of the warranty claim process.

**When submitting a warranty claim the following items are required:**

**1. Proof of purchase or installation of the product** – Typically a copy of the invoice from the installing contractor, the receipt of the purchase of the product, or an original certificate of occupancy for a new home.

**2. Clear pictures (or video) of the following:**

- a. Serial number tag (sticker)
- b. The product
- c. The product issue / failure whenever possible
- d. A picture of the piping near the product
- e. For gas fired products, a picture of the venting, including how it exits the building

All claims will be reviewed by HTP within three (3) business days. If

additional information is required and requested by the HTP Claims Department you will have thirty (30) days to provide it. When all requested information is provided HTP will respond within three (3) business days. The claim will be automatically closed if requested information is not provided within thirty (30) days. Claims will not be reopened without HTP Warranty Supervisor approval.

During the claims process a product that must be replaced will be given a designation of either a) field scrap, or b) return to HTP. If the product must be returned to HTP, the returned product must arrive at HTP within thirty (30) days of the date of our request to return the product. After receipt of the returned product HTP may require as many as thirty (30) additional days for product testing. **NOTE: Any components or heaters returned to HTP for warranty analysis will become the property of HTP and will not be returned, even if credit is denied.**

If you have questions about the coverage of this warranty, please contact HTP at the following address or phone number: HTP, 272 Duchaine Blvd., New Bedford, MA, 02745, Attention: Warranty Service Department, 1(800) 323-9651.

#### SERVICE, LABOR, AND SHIPPING COSTS

Except when specifically prohibited by the applicable state law, the Owner, and not the Manufacturer, shall be liable for and shall pay for all charges for labor or other expenses incurred in the removal, repair, or replacement of the water heater or any component part(s) claimed to be defective or any expense incurred to remedy any defect in the product. Such charges include, but are not necessarily limited to:

1. All freight, shipping, handling, and delivery costs of forwarding a new water heater or replacement part(s) to the owner.
2. All costs necessary or incidental in removing the defective water heater or component part(s) and installing a new water heater or replacement part(s).
3. All administrative fees incurred by the Owner, as well as material required to complete, and/or permits required for, installation of a new water heater or replacement part(s), and
4. All costs necessary or incidental in returning the defective water heater or component part(s) to a location designated by the manufacturer.

#### LIMITATIONS OF YOUR HTP WARRANTY AND REMEDIES

**THE FOREGOING WARRANTIES ARE EXCLUSIVE AND ARE GIVEN AND ACCEPTED TO THE FURTHEST EXTENT UNDER APPLICABLE LAW IN LIEU OF ANY AND ALL OTHER WARRANTIES, EXPRESS OR IMPLIED, INCLUDING WITHOUT LIMITATION THE IMPLIED WARRANTIES OF MERCHANTABILITY AND FITNESS FOR A PARTICULAR PURPOSE AND ANY OBLIGATION, LIABILITY, RIGHT, CLAIM OR REMEDY IN CONTRACT OR TORT, WHETHER OR NOT ARISING FROM HTP'S NEGLIGENCE, ACTUAL OR IMPUTED. THE REMEDIES OF THE OWNER SHALL BE LIMITED TO THOSE PROVIDED HEREIN TO THE EXCLUSION OF ANY OTHER REMEDIES INCLUDING WITHOUT LIMITATION, INCIDENTAL OR CONSEQUENTIAL DAMAGES, SAID INCIDENTAL AND CONSEQUENTIAL DAMAGES INCLUDING, BUT NOT LIMITED TO, PROPERTY DAMAGE, LOST PROFIT OR DAMAGES ALLEGED TO HAVE BEEN CAUSED BY ANY FAILURE OF HTP TO MEET ANY OBLIGATION UNDER THIS AGREEMENT INCLUDING THE OBLIGATION TO REPAIR AND REPLACE SET FORTH ABOVE. NO AGREEMENT VARYING OR EXTENDING THE FOREGOING WARRANTIES, REMEDIES OR THIS LIMITATION WILL BE BINDING UPON HTP. UNLESS IN WRITING AND SIGNED BY A DULY AUTHORIZED OFFICER OF HTP. THE WARRANTIES STATED HEREIN ARE NOT TRANSFERABLE AND SHALL BE FOR THE BENEFIT OF THE ORIGINAL OWNER ONLY.**

#### NO OTHER WARRANTIES

This warranty gives the Owner specific legal rights. The Owner may also have other rights that vary from state to state. Some states do not allow the exclusion or limitation of incidental or consequential damages so this limitation or exclusion may not apply to the Owner. These are the only written warranties applicable to this water heater manufactured and sold by HTP. HTP neither assumes nor authorizes anyone to assume for it any other obligation or liability in connection with said water heaters. HTP reserves the right to change specifications or discontinue models without notice.



**Customer Installation Record Form**

The following form should be completed by the qualified installer / service technician for you to keep as a record of the installation in case of a warranty claim. After reading the important notes at the bottom of the page, please also sign this document.

Customer's Name	
Date of Installation	
Installation Address	
Product Name / Serial Number(s)	
Comments	
Installer's Code / Name	
Installers Phone Number	
Signed by Installer	
Signed by Customer	
Installation Notes	

**IMPORTANT**

Customer: Please only sign after the qualified installer / service technician has fully reviewed the installation, safety, proper operation, and maintenance of the system. If the system has any problems please call the qualified installer / service technician. If you are unable to make contact, please call your sales representative.

Distributor / Dealer: Please insert contact details.