



**GE APPLIANCES**

# Service Manual

**NF96U\*\*\*S\*\*R**  
96% Upflow/Horizontal Single  
Stage Constant Torque Gas  
Furnace



**Contact GE Appliances at:**

Homeowner: [GEAppliances.com](http://GEAppliances.com)  
HVAC Pro: [GEAppliancesAirandWater.com](http://GEAppliancesAirandWater.com)  
or  
866.814.3633

Split System USAC and USHP matches:  
[AHRIDirectory.org](http://AHRIDirectory.org)

**READ CAREFULLY.  
KEEP THESE INSTRUCTIONS.**

# General Information

---

NF96U\*\*\*S\*\*R series units are high-efficiency gas furnaces manufactured with GE Appliances aluminized steel clamshell-type heat exchangers, with a stainless steel condensing coil. NF96U\*\*\*S\*\*R units are available in heating input capacities of 45,000 to 135,000 Btuh and cooling applications from 1.5 through 5 tons. Refer to Engineering Handbook for proper sizing.

Units are factory equipped for use with natural gas. A kit is available for conversion to LP/Propane operation. All NF96U\*\*\*S\*\*R units are equipped with a hot surface ignition system. The gas valve is redundant to assure safety shut-off as required by C.S.A.

The heat exchanger, burners and manifold assembly can be removed for inspection and service. The maintenance section gives a detailed description on how this is done.

All specifications are subject to change. Procedures outlined in this manual are presented as a recommendation only and do not supersede or replace local or state codes.

## **⚠ WARNING**

- This furnace is equipped with an ignition control factory enabled for use with A2L refrigerant systems. Disabling the refrigerant detection functionality on A2L system is prohibited by safety codes. Refer to furnace installation instructions for refrigerant system setup.
- Improper installation, adjustment, alteration, service or maintenance can cause property damage, personal injury or loss of life. Installation and service must be performed by a licensed professional HVAC installer or equivalent, service agency, or the gas supplier.

## **⚠ CAUTION**

As with any mechanical equipment, contact with sharp sheet metal edges can result in personal injury. Take care while handling this equipment and wear gloves and protective clothing.

# Technical Specifications

Gas Heating Performance	Model	NF96U045S3BR	NF96U070S3BR	NF96U090S4CR	NF96U110S5CR	NF96U135S5DR
	<sup>1</sup> AFUE	96%	96%	96%	96%	96%
	Input - Btuh	44,000	66,000	88,000	110,000	132,000
	Output - Btuh	43,000	64,000	86,000	107,000	127,000
	Temperature Rise Range - °F	35-65	35-65	50-80	45-75	45-75
	Gas Manifold Pressure (in. w.g.) Nat. Gas / LPG/Propane High static - in. w.g.	3.5 / 10.0	3.5 / 10.0	3.5 / 10.0	3.5 / 10.0	3.5 / 10.0
		0.5	0.5	0.5	0.5	0.5
<b>Energy Star® Certified</b>		Yes	Yes	Yes	Yes	Yes
<b>Connections</b>	Intake / Exhaust Pipe (PVC)	2/2	2/2	2/2	2/2	2/2
	Gas Pipe Size IPS	1/2	1/2	1/2	1/2	1/2
	Condensate Drain Trap (PVC pipe) - i.d.	3/4	3/4	3/4	3/4	3/4
	with furnished 90° street elbow	3/4 slip x 3/4 MIPT				
	with field supplied (PVC coupling) - o.d.	3/4 slip x 3/4 MIPT				
<b>Indoor Blower</b>	Wheel diameter x width - in.	10 x 8	10 x 8	10 x 10	11-1/2 x 10	11-1/2 x 10
	Motor Type	DC Brushless				
	Motor Output - HP	1/2	1/2	3/4	1	1
	Tons of add-on cooling	1.5 - 3	1.5 - 3	2.5 - 4	3-5	3-5
	Air Volume Range - CFM	520-1345	550-1380	760-1740	1055-2220	1310-2400
<b>Electrical Data</b>	Voltage	120 volts - 60 hertz - 1 phase				
	Blower motor full load amps	6.8	6.8	8.4	10.9	10.9
	Maximum overcurrent protection	15				
<b>Shipping Data</b>	lbs. - 1 package	124	129	152	164	174
<b>NOTE</b> - Filters and provisions for mounting are not furnished and must be field provided. <sup>1</sup> Annual Fuel Utilization Efficiency based on DOE test procedures and according to FTC labeling regulations. Isolated combustion system rating for non-weatherized furnaces.						

# Optional Accessories

		"B" Width Models	"C" Width Models	"D" Width Models	
<b>CONTROLS</b>					
Blower Relay Kit (for two-stage outdoor units)		85W66	85W66	85W66	
Remote Outdoor Temperature Sensor		X2658	X2658	X2658	
Transformer (75VA)		27J32	27J32	27J32	
<b>REFRIGERANT DETECTION SENSOR</b>					
Refrigerant Detection System (RDS) Coil Sensor Kit (for indoor coil)		27V53	27V53	27V53	
<b>TERMINATION KITS</b>					
See Installation Instructions for specific venting information.					
Direct Vent	Concentric	2 in.	71M80	69M29	---
		3 in.	---	60L46	60L46
	Flush-Mount	2, 2-1/2 or 3 in.	51W11	51W11	51W11
<sup>1</sup> Cleanable polyurethane frame type filter. <b>NOTE</b> - Termination Kits (30G28, 51W12, 81J20) are certified to ULC S636 standard for use in Canada only.					

Unit	Natural to LP/ Propane	High Altitude Natural Burner Orifice Kit	High Altitude LP/ Propane Burner Orifice Kit	High Altitude Pressure Switch	
				4501 - 7500 ft (1373 - 2286m)	7501 -10,000 ft (2286 - 3048m)
-045	11K49	73W37	11K44	11U66	11U69
-070				11U70	11U68
-090				11U70	11U64
-110				11U70	11U64
-135				11U70	11U68

Pressure switch is factory set. No adjustment necessary. All models use the factory-installed pressure switch from 0-4500 feet (0-1370 m).

## Burner Orifice Conversion Kits at Varying Altitudes

# Blower Data

## NF96U045S3BR PERFORMANCE (Less Filter)

External Static Pressure in. w.g.	Air Volume / Watts at Various Blower Speeds									
	High (Black)		Medium-High (Brown)		Medium (Blue)		Medium-Low (Yellow)		Low (Red)	
	CFM	Watt	CFM	Watt	CFM	Watt	CFM	Watt	CFM	Watt
0.10	1329	310	1191	233	1084	184	887	116	844	105
0.20	1298	320	1160	242	1050	192	846	122	801	111
0.30	1270	328	1129	251	1015	199	804	128	759	117
0.40	1239	337	1098	259	979	206	762	134	717	123
0.50	1209	346	1065	266	943	213	721	140	674	130
0.60	1181	355	1032	274	910	221	678	147	629	136
0.70	1154	364	1001	283	876	228	636	153	587	141
0.80	1124	373	971	292	841	236	598	159	547	147
0.90	1096	382	939	300	805	244	559	165	498	154
1.00	1069	392	907	308	769	251	510	172	444	159

## NF96U070S3BR PERFORMANCE (Less Filter)

External Static Pressure in. w.g.	Air Volume / Watts at Various Blower Speeds									
	High (Black)		Medium-High (Brown)		Medium (Blue)		Medium-Low (Yellow)		Low (Red)	
	CFM	Watt	CFM	Watt	CFM	Watt	CFM	Watt	CFM	Watt
0.10	1388	292	1244	221	1131	173	925	110	884	100
0.20	1359	302	1212	230	1096	182	886	116	843	107
0.30	1331	313	1182	238	1062	190	846	123	802	114
0.40	1301	323	1151	247	1028	198	805	130	759	120
0.50	1273	333	1121	256	996	206	764	137	717	127
0.60	1245	342	1090	265	961	215	720	145	670	134
0.70	1217	352	1059	274	928	223	671	151	616	140
0.80	1187	362	1026	283	892	231	623	157	566	146
0.90	1158	371	995	292	854	240	578	163	519	151
1.00	1128	381	962	302	814	248	532	169	464	156

## NF96U090S4CR PERFORMANCE (Less Filter)

External Static Pressure in. w.g.	Air Volume / Watts at Various Blower Speeds									
	High (Black)		Medium-High (Brown)		Medium (Blue)		Medium-Low (Yellow)		Low (Red)	
	CFM	Watt	CFM	Watt	CFM	Watt	CFM	Watt	CFM	Watt
0.10	1700	387	1489	274	1371	222	1289	193	1170	152
0.20	1664	400	1452	285	1331	233	1245	202	1123	161
0.30	1629	412	1413	296	1289	243	1202	211	1078	170
0.40	1596	424	1374	307	1248	252	1160	220	1031	178
0.50	1561	436	1337	317	1209	262	1117	229	987	186
0.60	1528	448	1300	328	1168	272	1073	237	933	194
0.70	1494	459	1261	338	1126	281	1029	246	885	201
0.80	1459	470	1221	347	1083	290	989	255	842	209
0.90	1425	482	1181	358	1042	299	949	264	798	217
1.00	1388	493	1142	368	1004	308	908	273	748	225

# Blower Data

## NF96U110S5CR PERFORMANCE (Less Filter)

External Static Pressure in. w.g.	Air Volume / Watts at Different Blower Speeds																			
	Bottom Return Air, Side Return Air with Return Air from Both Sides or Return Air from Bottom and One Side.										Single Side Return Air – Air volumes in bold (over 1800 cfm) require Optional Return Air Base and field fabricated transition to accommodate 20 x 25 x 1 in. air filter in order to maintain proper air velocity.									
	High (Black)		Medium-High (Brown)		Medium (Blue)		Medium-Low (Yellow)		Low (Red)		High (Black)		Medium-High (Brown)		Medium (Blue)		Medium-Low (Yellow)		Low (Red)	
	CFM	Watt	CFM	Watt	CFM	Watt	CFM	Watt	CFM	Watt	CFM	Watt	CFM	Watt	CFM	Watt	CFM	Watt	CFM	Watt
0.10	2159	658	1905	464	1744	364	1631	306	1451	227	2093	644	1858	438	1688	341	1590	281	1410	205
0.20	2122	674	1865	476	1701	376	1585	319	1403	240	2064	655	1824	451	1653	349	1546	296	1367	216
0.30	2087	689	1828	492	1657	389	1542	331	1360	252	2033	669	1788	467	1619	363	1511	306	1321	228
0.40	2051	705	1793	507	1616	402	1497	342	1310	262	1996	686	1749	482	1580	376	1473	322	1275	239
0.50	2016	721	1754	521	1574	415	1456	354	1260	271	1971	704	1709	498	1543	392	1436	330	1230	251
0.60	1982	736	1714	534	1534	426	1411	366	1213	282	1941	720	1676	512	1503	403	1387	347	1184	262
0.70	1947	751	1676	547	1494	439	1370	377	1167	291	1903	734	1644	524	1468	419	1351	356	1140	271
0.80	1913	767	1637	560	1454	450	1331	390	1118	302	1855	732	1606	542	1424	430	1313	369	1105	282
0.90	1876	782	1600	573	1415	462	1291	402	1066	312	1780	707	1571	554	1386	443	1273	380	1061	293
1.00	1841	795	1564	588	1376	474	1248	414	1012	321	1675	670	1535	569	1352	456	1238	392	1019	302

## NF96U135S5DR PERFORMANCE (Less Filter)

External Static Pressure in. w.g.	Air Volume / Watts at Different Blower Speeds																			
	Bottom Return Air, Side Return Air with Return Air from Both Sides or Return Air from Bottom and One Side.										Single Side Return Air – Air volumes in bold (over 1800 cfm) require Optional Return Air Base and field fabricated transition to accommodate 20 x 25 x 1 in. air filter in order to maintain proper air velocity.									
	High (Black)		Medium-High (Brown)		Medium (Blue)		Medium-Low (Yellow)		Low (Red)		High (Black)		Medium-High (Brown)		Medium (Blue)		Medium-Low (Yellow)		Low (Red)	
	CFM	Watt	CFM	Watt	CFM	Watt	CFM	Watt	CFM	Watt	CFM	Watt	CFM	Watt	CFM	Watt	CFM	Watt	CFM	Watt
0.10	2383	865	2200	687	2016	534	1791	385	1597	285	2340	883	2167	694	1995	534	1780	392	1611	291
0.20	2349	884	2165	703	1979	549	1750	400	1553	298	2303	901	2125	715	1956	551	1752	402	1560	306
0.30	2314	902	2130	720	1939	564	1709	413	1512	313	2277	912	2095	733	1920	566	1711	417	1527	316
0.40	2280	921	2096	739	1906	581	1668	427	1469	325	2253	933	2067	748	1882	581	1670	433	1479	329
0.50	2246	936	2060	754	1866	592	1629	441	1426	337	2215	951	2037	762	1850	595	1634	444	1444	342
0.60	2214	953	2028	771	1831	607	1586	453	1385	349	2188	967	2007	781	1816	608	1601	460	1404	355
0.70	2185	971	1996	786	1798	622	1544	465	1342	362	2159	989	1973	797	1779	627	1565	474	1363	368
0.80	2151	985	1960	802	1753	634	1506	478	1304	374	2127	1004	1938	815	1742	638	1525	487	1315	380
0.90	2098	983	1928	819	1722	650	1468	492	1260	384	2096	1023	1906	828	1716	655	1487	501	1276	390
1.00	2044	979	1898	836	1685	663	1430	504	1220	396	1997	936	1870	840	1670	670	1441	513	1237	399

# Parts Arrangement

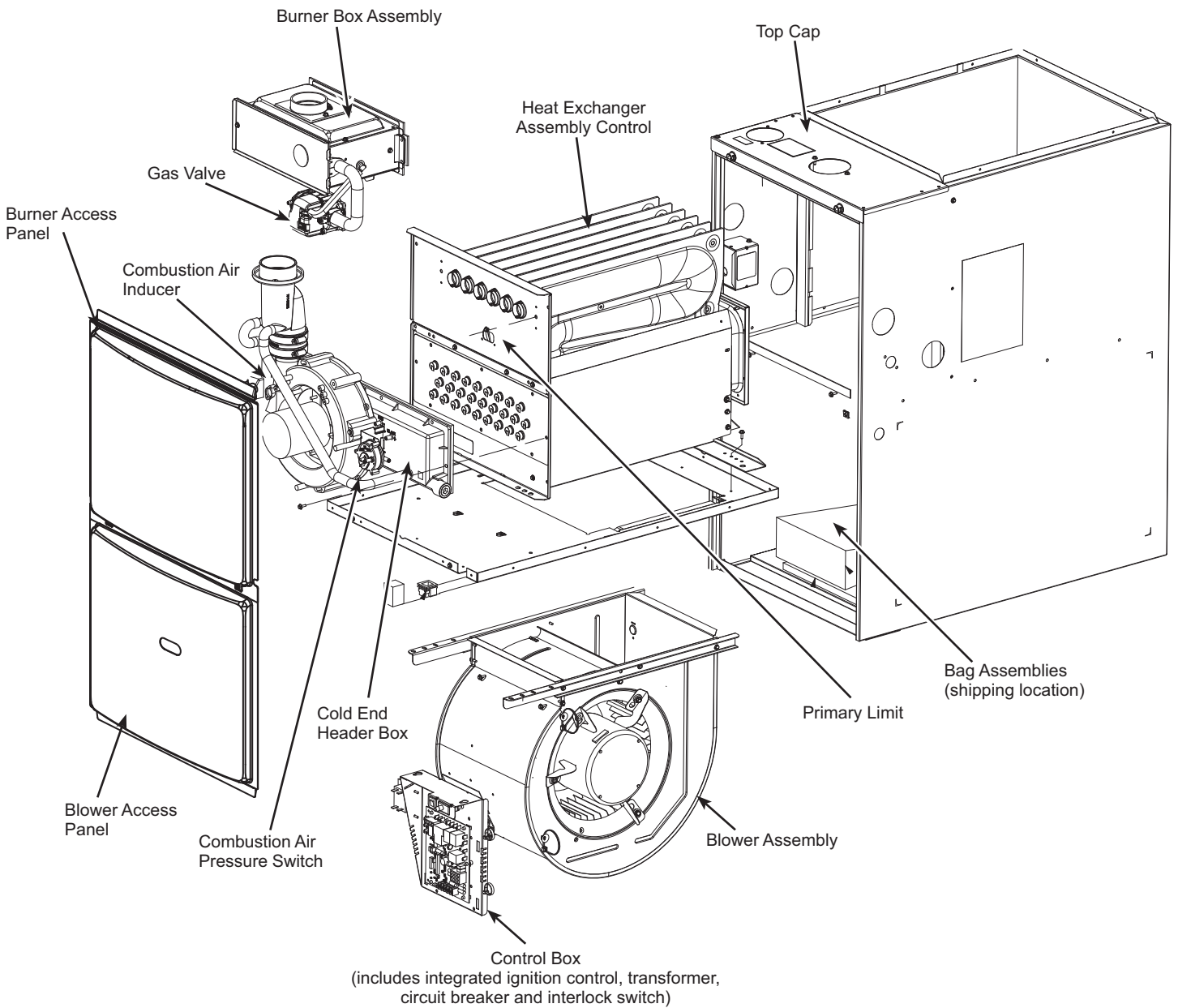


Figure 1.

# Service Information

## UNIT COMPONENTS

### ELECTROSTATIC DISCHARGE (ESD)

#### Precautions and Procedures

**⚠ CAUTION** Electrostatic discharge can affect electronic components. Take precautions to neutralize electrostatic charge by touching your hand and tools to metal prior to handling the control.

NF96U\*\*\*S\*\*R unit components are shown in **Figure 1**. The combustion air inducer, gas valve and burners can be accessed by removing the upper access panel. The blower and control box can be accessed by removing the blower access door.

### A - Control Box Components (Figure 2)

Unit transformer (T1) and integrated ignition control (A92) are located in the control box. In addition, a door interlock switch (S51) is located in the control box.

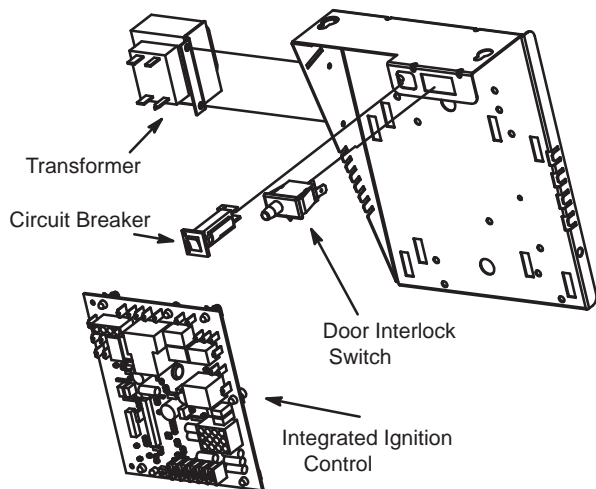


Figure 2.

#### 1. Transformer (T1)

A transformer located in the control box provides power to the low voltage section of the unit. Transformers on all models are rated 40VA with a 120V primary and 24V secondary.

#### ⚠ IMPORTANT

- When matching this gas furnace with zoning, dual fuel or other 24V accessories, It is recommended to replace the factory installed transformer with kit 27J32.
- Kit 27J32 contains a 75VA transformer, so you do not overload the original 40VA transformer.

#### 2. Door Interlock Switch (S51)

A door interlock switch rated 14A at 120VAC is located on the control box. The switch is wired in series with line voltage. When the blower door is removed the unit will shut down.

#### 3. Circuit Breaker (CB8)

A 24V circuit breaker is also located in the control box. The switch provides overcurrent protection to the transformer (T1). The breaker is rated at 3A at 32V. If the current exceeds this limit the breaker will trip and all unit operation will shut down. The breaker can be manually reset by pressing the button on the face.

#### 4. Ignition Control 107792-XX (Figure 6)

#### ⚠ WARNING Shock hazard.

- Disconnect power before servicing. Control is not field repairable. If control is inoperable, simply replace entire control.
- Can cause injury or death. Unsafe operation will result if repair is attempted.

#### Integrated Control DIP Switch Settings

NF96U\*\*\*S\*\*R units are equipped with a single-stage integrated control. This control manages ignition timing, heating mode fan off delays and indoor blower speeds based on selections made using the control dip switches and jumpers. The control includes an internal Soft Lockout feature which automatically resets the ignition control when it has been locked out. After one hour of continuous thermostat demand for heat, the Soft Lockout will break and remake thermostat demand to the furnace and automatically reset the control to relight the furnace.

#### Accessory Terminals

One line voltage "ACC" 1/4" spade terminal is provided on the furnace integrated control. This terminal is energized when the indoor blower is operating. Any accessory rated up to one amp can be connected to this terminal with the neutral leg of the circuit being connected to one of the provided neutral terminals. If an accessory rated at greater than one amp is connected to this terminal, it is necessary to use an external relay.

One line voltage "HUM" 1/4" spade terminal is provided on the furnace integrated control. This terminal is energized in the heating mode when the combustion air inducer is operating. Any humidifier rated up to one amp can be connected to this terminal with the neutral leg of the circuit being connected to one of the provided neutral terminals. If a humidifier rated at greater than one amp is connected to this terminal, it is necessary to use an external relay.

One 24V "H" 1/4" spade terminal is provided on the furnace integrated control. The terminal is energized in the heating mode when the combustion air inducer is operating and the pressure switch is closed. Any humidifier rated up to 0.5 amp can be connected to this terminal with the ground leg of the circuit connected to ground or the "C" terminal.

# Service Information

## INDOOR BLOWER OPERATION DIP SWITCH SETTINGS

The heat fan-on time of 30 seconds is not adjustable. The heat fan-off delay (amount of time that the blower operates after the heat demand has been satisfied) may be adjusted by changing the two position dip switch on the integrated control, to one of four selections. Blower off delay is factory set at 120 seconds. For other blower off delay settings, please refer to the following chart:

Blower Delay Select		
	SW1-1	SW1-2
90	OFF	ON
120	OFF	OFF
180	ON	OFF
210	ON	ON
Factory Setting is 120		

### On Board Links (Figure 3 and Figure 4) and Diagnostic Push Button

**▲ IMPORTANT** Carefully review all configuration information provided. Failure to properly set DIP switches, jumpers and on-board links can result in improper operation!

#### On-Board Link W951 Heat Pump (R to O)

On-board link W951 is a clippable connection between terminals R and O on the integrated control. W951 must be cut when the furnace is installed in applications which include a heat pump unit and a thermostat which features dual fuel use. If the link is left intact, terminal “O” will remain energized eliminating the **HEAT MODE** in the heat pump.

#### Diagnostic Push Button

The diagnostic push button is located adjacent to the seven-segment diagnostic LED. This button is used to enable the Error Code Recall “E” mode and the Flame Signal “F” mode. Press the button and hold it to cycle through a menu of options. Every five seconds a new menu item will be displayed. When the button is released, the displayed item will be selected. Once all items in the menu have been displayed, the menu resumes from the beginning until the button is released.

The hot surface ignition control system consisting of an integrated control (Figure 6) with control terminal designations in Table 1, Table 2, Table 3, sensor and ignitor (Figure 7). The integrated control and ignitor work in combination to ensure furnace ignition and ignitor durability. The integrated control, controls all major furnace operations. The integrated control also features a RED LED for troubleshooting and two accessory terminals rated at (1) one amp. See Table 4 for troubleshooting diagnostic codes. The nitride ignitor is made from a non-porous, high strength proprietary ceramic material that provides long life and trouble free maintenance.

Table 1.

1/4" Quick Connect Terminals	
120V HUM	Power for Humidifier (120VAC)
LINE	Incoming Power Line (120VAC)
XFMR	Transformer Primary (120VAC)
CIRC	Indoor Blower Motor (120VAC)
ACC	Accessory (120VAC)
24V HUM	Humidifier (24VAC)
NEUTRALS	Neutral (5)
3/16" Quick Connect Terminals	
COOL	Cool Speed Tap from Indoor Blower Motor (24VAC)
HEAT	Heat Speed Tap from Indoor Blower Motor (24 VAC)
FAN	Continuous Fan Speed Tap From Indoor Blower Motor (24 VAC)
FLAME SENSE	Flame Sensor Electrode (120 VAC)
COMMON	Common (24VAC)
PARK	3 Terminals to Park Unused Motor Speed Taps

Table 2.

Thermostat Input Terminals	
W	Heat
C	Common Ground
R	24V AC
G	Fan
Y	Cool
O	Reversing Valve (when W951 is clipped)

Table 3.

Low GWP Interface	
LGWP1	Low GWP Sensor #1 Interface
LGWP2	Low GWP Sensor #2 Interface
ALARM	Interface to Low GWP Leak Audible Alarm (Dry Contact)
ZONE	Interface to Zoning Control (Dry Contact)
LGWP TEST	Push Button to Test Low GWP Functionality

# Service Information

## INDOOR BLOWER OPERATION DIP SWITCH SETTINGS (CONT)

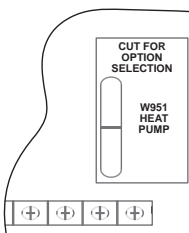
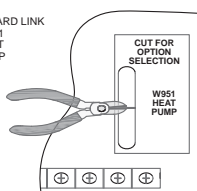
Thermostat	On Board Links Must NOT Be Cut To Select AC ON System Options	Wiring Connections
Heat / Cool	<p>DO NOT CUT ANY ON-BOARD LINKS</p> 	<p>S1 T*STAT      FURNACE TERM. STRIP      OUTDOOR UNIT</p> <p>W-----W R-----R-----R G-----G C-----C Y-----Y</p>

Figure 3.

Thermostat	On Board Links Must Be Cut To Select Heat Pump Options	Wiring Connections
Dual Fuel Single Stage Heat Pump	<p>CUT ON-BOARD LINK W951 HEAT PUMP</p> 	<p>T*STAT      FURNACE TERM. STRIP      HEAT PUMP</p> <p>R-----R-----R</p> <p>W-----W ← 67M41* → W G-----G Y-----Y C-----C C-----C</p>

\*Connect W to W ONLY if using defrost tempering kit 67M41

Figure 4.

### HEATING IGNITION SEQUENCE

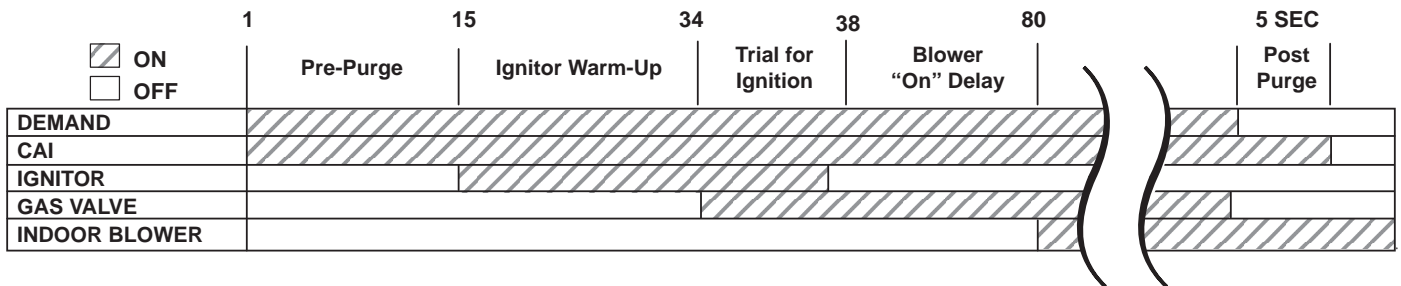


Figure 5.

### Heating Ignition Sequence (Figure 5)

On a call for heat the integrated control monitors the combustion air inducer pressure switch. The control will not begin the heating cycle if the pressure switch is closed (bypassed). Once the pressure switch is determined to be open, the combustion air inducer is energized. When the differential in the pressure switch is great enough, the pressure switch closes and a 15-second pre-purge begins. After 5-minute wait period expires, the control shall start the Ignition Sequence from the beginning if the call for heat is still present.

After the 15-second pre-purge period, the ignitor warms up for 20 seconds during which the gas valve opens at 19 seconds for a 4-second trial for ignition. The ignitor remains energized for the first 3 seconds during the 4 second trial. If ignition is not proved during the 4-second period, the integrated control will try four more times with an inter purge and warm-up time between trials of 35 seconds. After a total of five trials for ignition (including the initial trial), the integrated control goes into Soft Lockout-Flame Failure mode. After a 60-minute reset period, the integrated control will begin the ignition sequence again.

# Service Information

## Single Stage, Constant, Torque, Non-Communicating

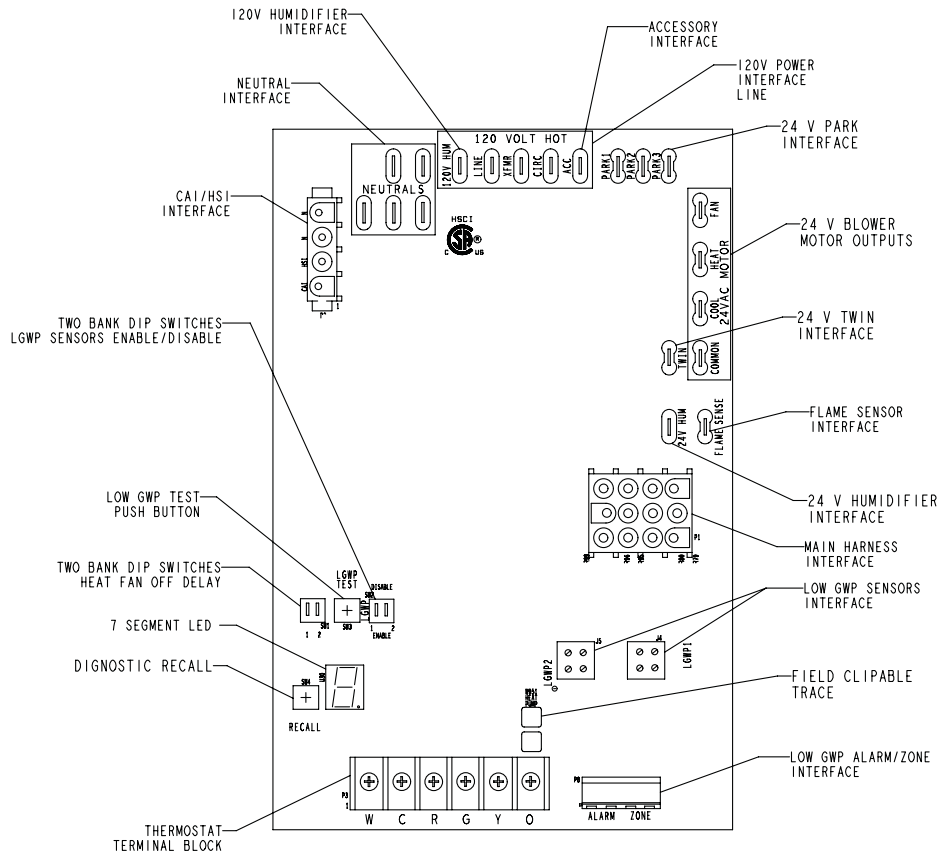


Figure 6.

### Indoor Blower Speeds

- 1 - When the thermostat is set to **FAN ON**, the indoor blower will run continuously on the fan speed when there is no cooling or heating demand. See table below for allowable circulation speeds.
- 2 - When the unit is running in the heating mode, the indoor blower will run on the heating speed. See table below for allowable heating speeds.
- 3 - When there is a cooling demand, the indoor blower will run on the cooling speed.

Allowable Circulation Speeds					
Model Number	Red	Yellow	Blue	Brown	Black
All Models	Factory Setting	Not Allowed			

Allowable Heating Speeds					
Model Number	Red	Yellow	Blue	Brown	Black
NF96U045S3BR	Allowed	Factory Setting	Allowed	Allowed	Not Allowed
NF96U070S3BR	Not Allowed	Not Allowed	Factory Setting		
NF96U090S4CR	Allowed	Factory Setting	Allowed		
NF96U110S5CR	Not Allowed	Allowed	Factory Setting	Not Allowed	
NF96U135S5DR				Not Allowed	

# Service Information

**Table 4.**  
**Integrated Diagnostic Codes/Status of Equipment**

Integrated Diagnostic Codes/Status of Equipment		
Code	Diagnostic Codes/Status of Equipment	
A	Indoor Blower Operation: Continuous Fan only mode	
dF	Defrost mode	
.	Idle mode (Decimal blinks at 1 Hertz -- 0.5 second ON, 0.5 second OFF).	
C	Cooling stage (1 second ON, 0.5 second OFF) 1 or 2 displayed / Pause / Repeat codes.	
d	Dehumidification mode (1 second ON, 1 second OFF) / Pause / Repeat Codes).	
H	Gas Heat Stage (1 second ON, 0.5 second OFF) 1 or 2 displayed / Pause / Repeat codes. Blinking during ignition.	
h	Heat pump stage.	
* No change implies the display will continue to show whatever is currently being displayed for normal operation (blinking decimal, active error code, heat state, etc.)		
Code	Diagnostic Codes/Status of Equipment	Action Required to Clear and Recover
E000	No error in memory	No active fault exists, or all faults have been cleared
E106	Twin Communication Fault	This may indicate: 1) The power is removed from one furnace and not the other or/ and, 2) The 24 VAC supply to the twins are not in phase
E110	Low line voltage.	Line Voltage Low (Voltage lower than nameplate rating). Check power line voltage and correct. Alarm clears 5 seconds after fault recovered.
E111	Line voltage polarity reversed.	Reverse line power voltage wiring. System resumes normal operation 5 seconds after fault recovered.
E112	Ground not detected.	System shuts down. Provide proper earth ground. System resumes normal operation 5 seconds after fault recovered.
E113	High line voltage.	Line Voltage High (Voltage higher than nameplate rating). Provide power voltage within proper range. System resumes normal operation 5 seconds after fault recovered.
E114	Line voltage frequency out-of-range.	No 60 Hertz Power. Check voltage and line power frequency. Correct voltage and frequency problems. System resumes normal operation 5 seconds after fault recovered.
E115	Low 24V - Control will restart if the error recovers.	24-Volt Power Low (Range is 18 to 30 volts). Check and correct voltage. Check for additional power-robbing equipment connected to system. May require installation of larger VA transformer to be installed in furnace / air handler. Clears after fault recovered.
E117	Poor ground detected (Warning only).	Provide proper grounding for unit. Check for proper earth ground to the system. Warning only will clear 30 seconds after fault recovered.

# Service Information

Table 4. (Cont.)

Code	Diagnostic Codes/Status of Equipment	Action Required to Clear and Recover
E125	Control failed self-check, internal error, failed hardware. Will restart if error recovers. Integrated control not communicating. Covers hardware errors (flame sense circuit faults, pin shorts, etc.).	Hardware problem on the control. Cycle power on control. Replace if problem prevents service and is persistent. Critical alert. Cleared 300 seconds after fault recovered.
E150	Refrigerant Leak detected	This may indicate the presence of a leak at or in the indoor unit coil of the equipment, that will need to be repaired for proper and safe system operation. Additionally, it may indicate that proper refrigerant charge will need to be verified. This fault cannot be cleared while the refrigerant detection system sensor is reporting the presence of a leak
E151	Refrigerant Leak Detector Sensor #1 fault	The refrigerant detection sensor #1 in the unit is reporting an issue that prevents it from functioning properly, and replacement of the sensor may be necessary. This fault clears when the sensor no longer reports the presence of a fault condition.
E152	Refrigerant Leak Detector Sensor #2 fault	The refrigerant detection sensor #2 in the unit is reporting an issue that prevents it from functioning properly, and replacement of the sensor may be necessary. This fault clears when the sensor no longer reports the presence of a fault condition.
E154	Refrigerant Leak Detector Sensor #1 Communication lost or invalid sensor dip switch configuration (ON/OFF)	There may be an issue with the wiring harness connecting the sensor #1 to the furnace control board, either with the wiring itself or with the connector. Check the wiring and the connector for damage or improper connectivity. Check the sensor for damage or obstruction on the harness plug. This fault clears when communications with the sensor has been reestablished, but blower latches for a minimum of 5 minutes. Retest of the presence of fault can be effected by pressing the Low GWP test button on the furnace unit control board. This may also indicate incorrect Low GWP dip switch settings. Please refer to installation instructions.
E155	Refrigerant Leak Detector Sensor #2 Communication lost	There may be an issue with the wiring harness connecting the sensor #2 to the furnace control board, either with the wiring itself or with the connector. Check the wiring and the connector for damage or improper connectivity. Check the sensor for damage or obstruction on the harness plug. This fault clears when communications with the sensor has been reestablished, but blower latches for a minimum of 5 minutes. Retest of the presence of fault can be effected by pressing the Low GWP test button on the furnace unit control board
E160	Refrigerant Leak Detector Sensor #1 type incorrect	The sensor #1 is of a type not suitable for use in the application. Replace the sensor with a GE Appliances approved replacement part. This fault clears when a sensor suitable for the application is detected by the furnace control board, but blower will latch for a minimum of 5 minutes. Retest of the presence of the fault can be effected by pressing the Low GWP test button on the furnace unit control board.
E161	Refrigerant Leak Detector Sensor #2 type incorrect	The sensor #2 is of a type not suitable for use in the application. Replace the sensor with a GE Appliances approved replacement part. This fault clears when a sensor suitable for the application is detected by the furnace control board, but blower will latch for a minimum of 5 minutes. Retest of the presence of the fault can be effected by pressing the Low GWP test button on the furnace unit control board.
E163	Furnace Control Board Failure	There is an issue with the furnace control board, preventing the furnace from operating properly. This may require the replacement of the indoor unit control board. This fault clears when the furnace controller operates normally.

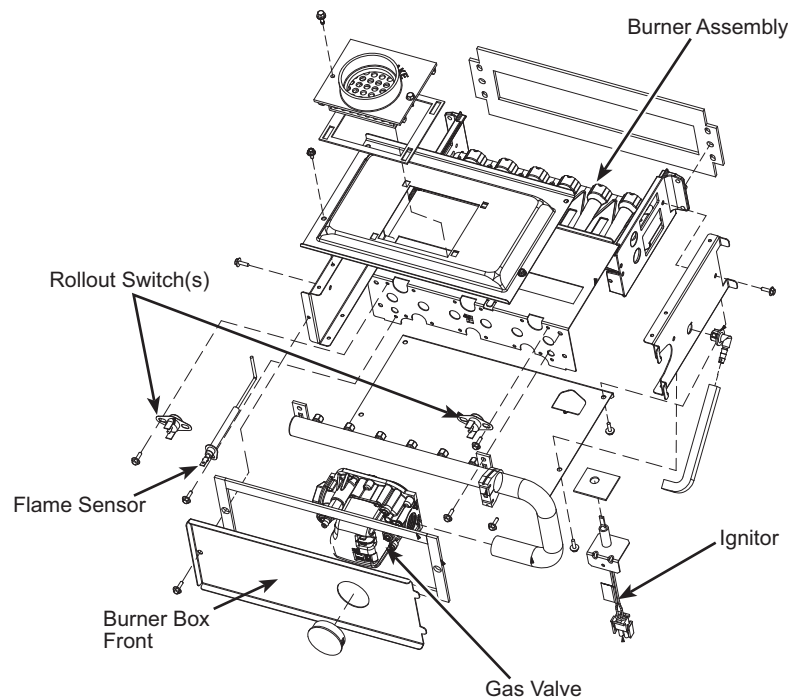
# Service Information

Table 4 (Cont.)

Code	Diagnostic Codes/Status of Equipment	Action Required to Clear and Recover
E164	Low GWP Test	Low GWP Test mode activates by manually engaging Low GWP test button. Normal operations resumes and code clears automatically after 1-minute
E200	Hard lockout - Rollout circuit open or previously open.	Correct cause of rollout trip, or replace flame rollout switch. Test furnace operation. Cleared after fault recovered.
E204	Gas valve mis-wired.	Check gas valve operation and wiring. Clears when repaired.
E223	Low pressure switch failed open.	Check pressure (inches w.c.) of low pressure switch closing on heat call. Measure operating pressure (inches w.c.). Inspect vent and combustion air inducer for correct operation and restriction. Resumes normal operation after fault is cleared.
E224	Low pressure switch failed closed.	Check pressure (inches w.c.) of low pressure switch closing on heat call. Measure operating pressure (inches w.c.). Inspect vent and combustion air inducer for correct operation and restriction. Resumes normal operation after fault is cleared.
E227	Low pressure switch open during trial for ignition or run mode.	Check pressure (inches w.c.) of low pressure switch closing on heat call. Measure operating pressure (inches w.c.). Inspect vent and combustion air inducer for correct operation and restriction. Resumes normal operation after fault is cleared.
E240	Low flame current - Run mode.	Check micro-amperes of flame sensor using control diagnostics or field-installed mode. Clean or replace sensor. Measure voltage of neutral to ground to ensure good unit ground. Alert clears after current heat call has been completed.
E241	Flame sensed out of sequence - Flame still present.	Shut off gas. Check for gas valve leak. Replace, if necessary. Alert clears when fault is recovered.
E250	Limit switch circuit open.	Check for proper firing rate on furnace. Ensure there is no blockage in heater. Check for proper air flow. If limit not closed within 3 minutes, unit will go into 1-hour soft lockout. Resumes normal operation after fault is cleared.
E270	Soft lockout - Exceeded maximum number of retries. No flame current sensed.	Check for proper gas flow. Ensure that ignitor is lighting burner. Check flame sensor current. Clears when heat call finishes successfully.
E271	Soft lockout - Exceeded maximum number of retries. Last retry failed due to the pressure switch opening.	Check pressure (inches w.c.) of low pressure switch closing on heat call. Measure operating pressure (inches w.c.). Inspect vent and combustion air inducer for correct operation and restriction. Clears when heat call finishes successfully.
E272	Soft lockout - Exceeded maximum number of recycles. Last recycle due to the pressure switch opening.	Check operation of low pressure switch to see if it is stuck closed on heat call. Check pressure (inches w.c.) of high pressure switch closing on heat call. Measure operating pressure (inches w.c.). Inspect vent and combustion air inducer for correct operation and restriction. Clears when heat call finishes successfully.
E273	Soft lockout - Exceeded maximum number of recycles. Last recycle due to flame failure.	Check micro-amperes of flame sensor using control diagnostics or field-installed mode. Clean or replace sensor. Measure voltage of neutral to ground to ensure good unit ground. Clears when heat call finishes successfully.
E274	Soft lockout - Exceeded maximum number of recycles. Last recycle failed due to the limit circuit opening or limit remained open longer than 3 minutes.	Shut down system. 1-hour soft lockout. Check firing rate and air flow. Check for blockage. Clears when heat call finishes successfully.
E275	Soft lockout - Flame sensed out of sequence. Flame signal is gone.	Shut off gas. Check for gas valve leak. 1-hour soft lockout. Clears when flame has been proven stable.
E290	Ignitor circuit fault - Failed ignitor or triggering circuitry.	Measure resistance of hot surface ignitor. Replace if open or not within specifications. 1-hour soft lockout. Clears when flame has been proven stable.
E390	Low GWP Relay Stuck	This indicates an issue with the Low GWP relay in the furnace control. This may require the replacement of the indoor unit control board. This fault clears when the relay operates normally.

# Service Information

## B - Heating Components (Figure 7)



**Figure 7. Burner Box Assembly**

Combustion air inducer (B6), primary limit control (S10), ignitor, burners, flame rollout switch (S47), gas valve (GV1), combustion air pressure switch (S18), and heat exchangers are located in the heating compartment. The heating compartment can be accessed by removing the outer access panel.

### 1. Flame Rollout Switches

Flame rollout switches S47 are SPST N.C. high temperature limits located on the left and right of the front burner box plate. S47 is wired to the burner ignition control A92. When either of the switches sense flame rollout (indicating a blockage in the combustion passages), the flame rollout switch trips, and the ignition control immediately closes the gas valve. Switch S47 in all NF96U\*\*\*S\*\*R units is factory preset to open at 210 F + 12 F (99 C + 6.7 C) on a temperature rise. All flame rollout switches are manual reset.

### 2. Ignitor

Units use a nitride ignitor made from a proprietary ceramic material. To check ignitor, measure its resistance and voltage. A value of 39 to 70 ohms indicates a good ignitor. Voltage to the ignitor should be 102 - 132VAC. See **Figure 9** for resistance and voltage checks.

### 3. Flame Sensor

A flame sensor is located on the left side of the burner support. The sensor is mounted on the front burner box plate and the tip protrudes into the flame envelope of the leftmost burner. The sensor can be removed for service (use steel wool only to clean) without removing any part of the burners. During operation, flame is sensed by current

passed through the flame and sensing electrode. The ignition control allows the gas valve to remain open as long as flame signal is sensed.

**NOTE:** The NF96U\*\*\*S\*\*R is polarity sensitive. Make sure that the furnace is wired correctly and is properly grounded.

A microamp DC meter is needed to check the flame signal on the integrated control.

Flame (microamp) signal is an electrical current which passes from the integrated control to the sensor during unit operation.

Current passes from the sensor through the flame to ground to complete a safety circuit.

### To Measure Flame Signal - Integrated Control:

Use a digital readout meter capable of reading DC microamps.

See **Figure 8** for flame signal check.

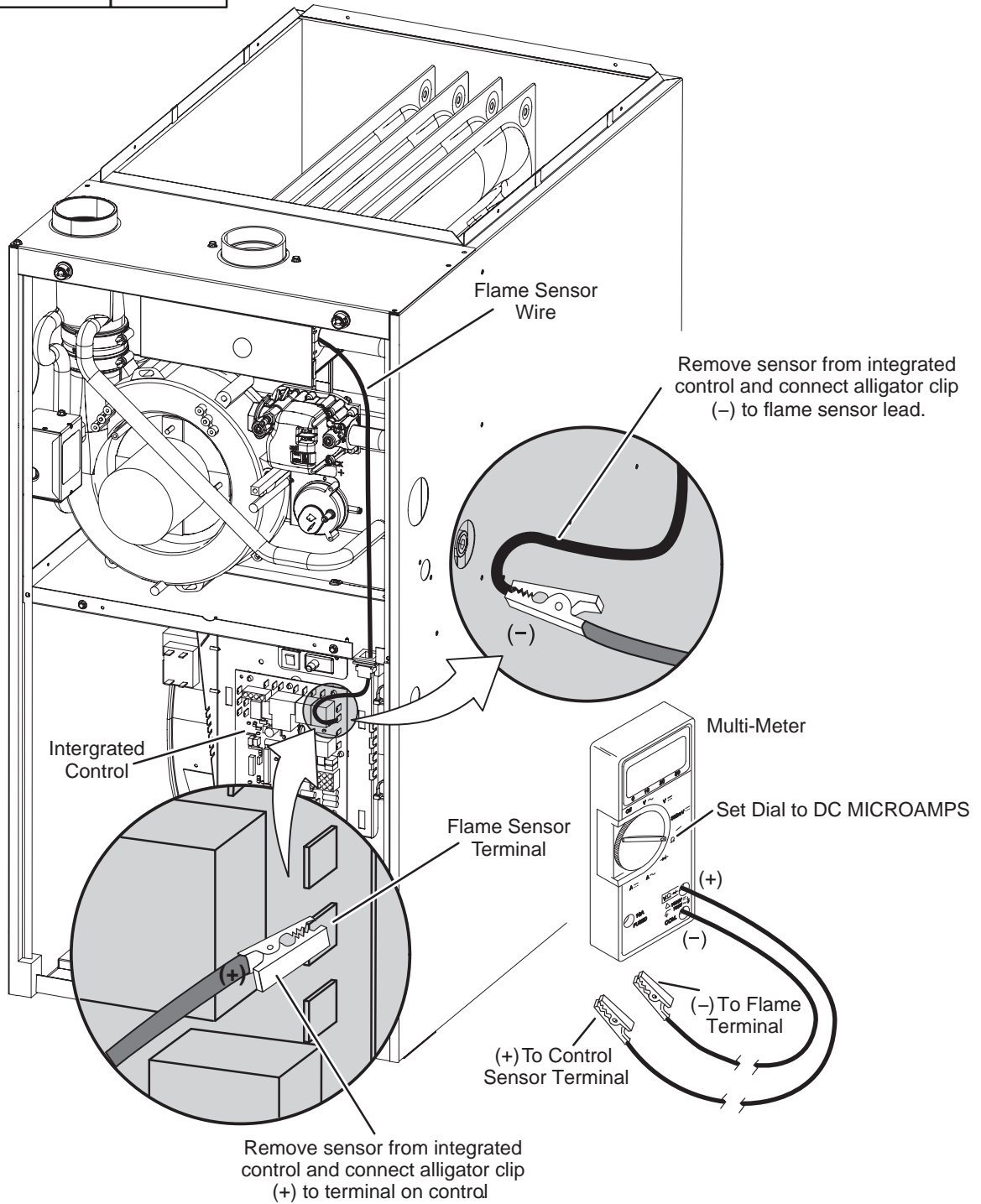
1. Set the meter to the DC amps scale.
2. Turn off supply voltage to control.
3. Remove sensor wire from integrated control.
4. Connect (-) lead to flame sensor wire.
5. Connect (+) lead to Terminal "Flame Sense" on integrated control.
6. Turn supply voltage on and close thermostat contacts to cycle system.
7. When main burners are in operation for two minutes, take reading.

# Service Information

## B - Heating Components (Cont.)

**Flame Signal In Microamps**

Normal	Low	Drop Out
$\geq 1.5$	0.5 - 1.4	$\leq 0.4$



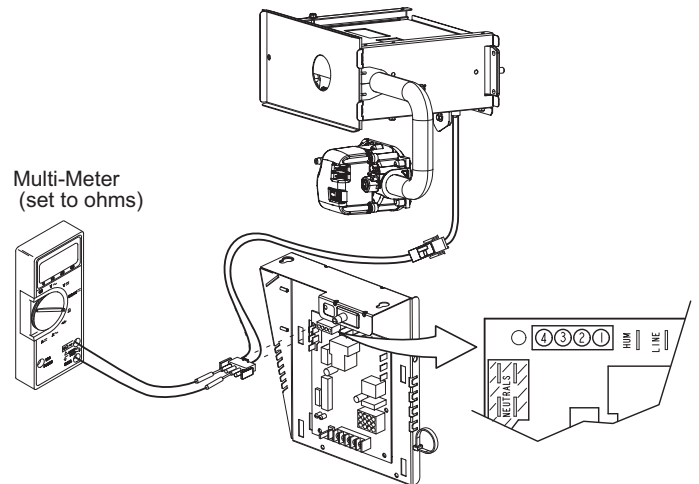
**Figure 8. Measuring Flame Signal**

# Service Information

## Test 1

### Check ignitor circuit for correct resistance.

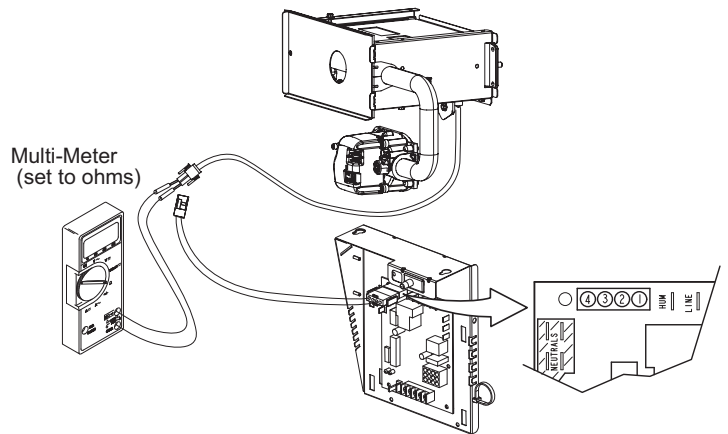
Remove HSI/CAI 4-pin plug from control. Check ohms reading across terminals 2 and 4. Reading should be between 39 and 70 ohms. If value is correct, this is the only test needed. If the reading on the meter is not correct, (0 or infinity) then a second test is needed.



## Test 2

### Check ignitor for correct resistance.

Separate the 2-pin jack-plug near the manifold and check resistance of ignitor at the plug. Reading should be between 39 and 70 ohms. If the reading is correct, then the problem is with the wiring between the jack-plug and the control. If reading is not correct, the issue is the ignitor



## Test 3

### Check ignitor for correct voltage.

Insert meter probes into terminals 2 and 4 (use small diameter probes in order not to damage plug). Check voltage during 20 second ignitor warm up period. Voltage should read 120 volts + 10%. If voltage reads below these values, check for correct supply voltage to furnace.

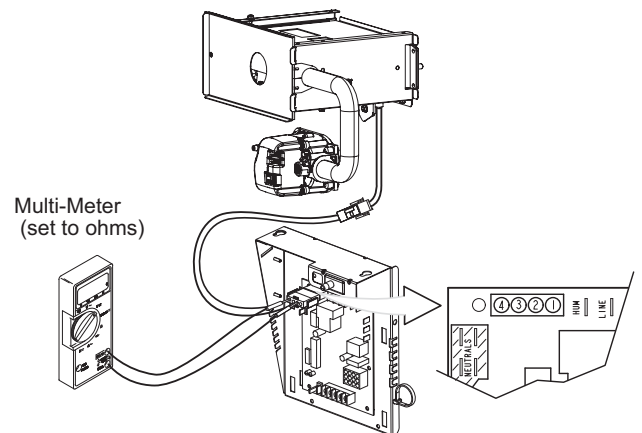


Figure 9.

# Service Information

## 4. Heat Exchanger (Figure 10)

Units use an aluminized steel primary and stainless steel secondary heat exchanger assembly. Heat is transferred to the air stream from all surfaces of the heat exchanger. The shape of the heat exchanger ensures maximum efficiency.

The combustion air inducer pulls fresh air through the burner box. This air is mixed with gas in the burners. The gas / air mixture is then burned at the entrance of each clamshell. Combustion gases are then pulled through the primary and secondary heat exchangers and exhausted out the exhaust vent pipe.

## 5. Primary Limit Control

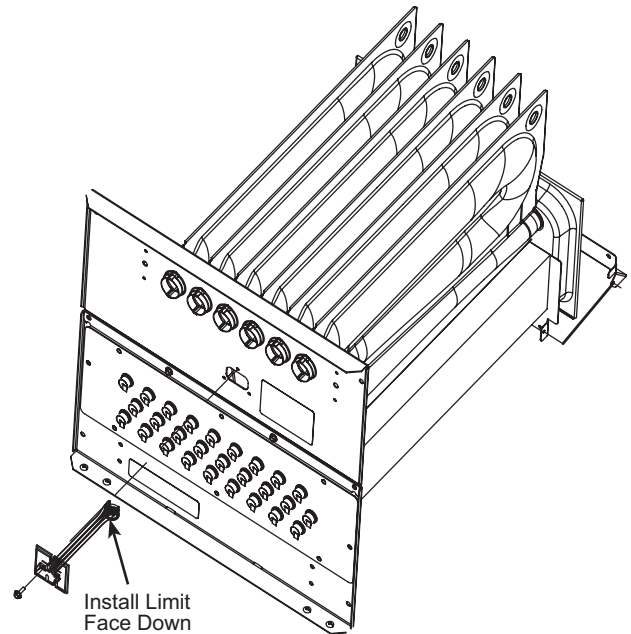
Primary limit (S10) used on NF96U\*\*\*S\*\*R units is located in the heating vestibule pane (**Figure 10**). When excess heat is sensed in the heat exchanger, the limit will open. Once the limit opens, the furnace control energizes the supply air blower and de-energizes the gas valve. The limit automatically resets when unit temperature returns to normal. The switch is factory set and cannot be adjusted. For limit replacement remove wires from limit terminals, remove mounting screws, rotate limit switch 90 degrees and slowly remove from the vestibule panel. Install replacement limit with same care.

## 5. Gas Valve (Figure 11)

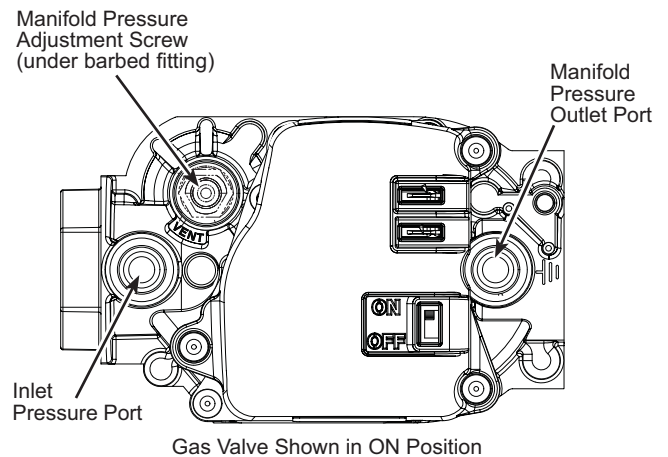
Units use an internally redundant valve to assure safety shut-off. If the gas valve must be replaced, the same type valve must be used.

24VAC terminals and gas control switch are located on top of the valve. All terminals on the gas valve are connected to wires from the ignition control. 24V applied to the terminals opens the valve.

Inlet and outlet pressure taps are located on the valve. A manifold adjustment screw is also located on the valve. An LP/Propane changeover kit is available.



**Figure 10. Primary Limit Location and Heat Exchanger**



**Figure 11. Gas Valve**

# Service Information

## 7. Combustion Air Inducer & Cold End Header Box

All NF96U\*\*\*S\*\*R units use a combustion air inducer (B6) to move air through the burners and heat exchanger during heating operation. The blower uses a shaded pole 120VAC motor. The motor operates during all heating operation and is controlled by integrated control A92. Blower operates continuously while there is a call for heat. The integrated control will not proceed with the ignition sequence until combustion air inducer operation is sensed by the proving switches.

The combustion air inducer is installed on the cold end header box. The cold end header box is a single piece made of hard plastic. The box has an internal channel where the combustion air inducer creates negative pressure at unit start up. The channel contains an orifice used to regulate flow created by the combustion air inducer.

The box has pressure taps for the combustion air inducer pressure switch hoses. The pressure switch measures the pressure across the combustion air inducer orifice or difference in the channel and the box. **If replacement is necessary the gaskets used to seal the box to the vestibule panel and the combustion air inducer to the box, must also be replaced.**

Table 5.

Unit	Combustion Air Inducer Orifice Size
-045	0.618"
-070	0.775"
-090	0.905"
-110	1.040"
-135	1.235"

## 8. Combustion Air Pressure Switch (Figure 12)

NF96U\*\*\*S\*\*R series units are equipped with a differential pressure switch located on the cold end header box. The switch monitors across the combustion air inducer orifice to insure proper flow through the heat exchanger.

The switch is a SPST N.O. pressure switch electrically connected to the integrated control. The purpose of the switch is to prevent burner operation if the combustion air inducer is not moving enough air for proper combustion.

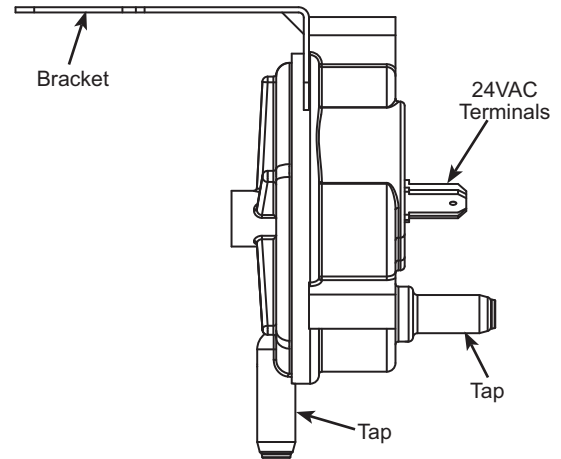


Figure 12. Pressure Switch

On start-up, the switch monitors whether the combustion air inducer is operating. It closes a circuit to the integrated control when the difference in pressure across the combustion air inducer orifice exceeds a non-adjustable factory setting. If the switch does not successfully sense the required differential, the switch cannot close and the furnace cannot operate. If the flue or air inlet become obstructed during operation, the switch senses a loss of pressure differential and opens the circuit to the integrated control. If the condensate line is blocked, water will back up into the header box and reduce the pressure differential across the switch. The pressure switch opens if the differential drops below the set point. See **Table 6**.

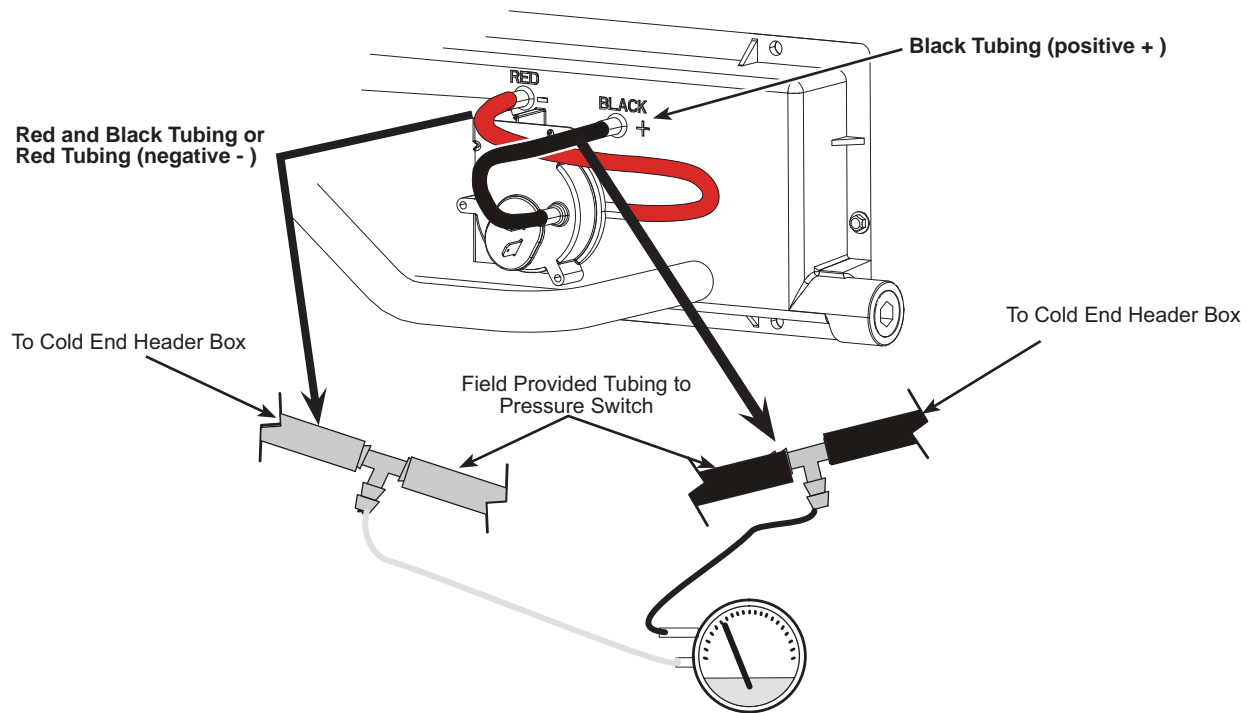
Checks of pressure differential can aid in troubleshooting. When measuring the pressure differential, readings should be taken at the pressure switch. See **Figure 13** and **Table 7**. Lack of differential usually indicates problems in the intake or exhaust piping, but may indicate problems in the heat exchanger, condensing coil, header boxes, combustion inducer or other components.

Table 6.

Unit	Altitude Ft		
	0-4500	4501-7500	7501-10000
	Set Point "w.c.	Set Point "w.c.	Set Point "w.c.
-045	-0.65	-0.65	-0.60
-070	-0.95	-0.65	-0.75
-090	-0.90	-0.80	-0.65
-110	-0.90	-0.85	-0.65
-135	-0.90	-0.80	-0.65

\*Set point is factory set and non-adjustable.

# Service Information



1. Remove thermostat demand and allow unit to cycle off.
  2. Install a tee in the negative (-) line (red and black tubing or red tubing) and a tee in the positive (+) line (black tubing) running from the pressure switch to the cold end header box.
  3. Install a manometer with hose from the negative (-) side of the manometer to the tee installed in the negative (-) line and with hose from the positive (+) side of the manometer to the tee in the positive (+) line.
  4. Operate unit and observe manometer reading. Readings will change as heat exchanger warms.
    - a. Take one reading immediately after startup.
    - b. Take a second reading after unit has reached steady state (approximately 5 minutes). This will be the pressure differential.  
**The pressure differential should be greater than those listed in Table 7.**
  5. Remove thermostat demand and allow to cycle off.
  6. Remove manometer and tee's. Reinstall combustion air sensing hoses to the pressure switch.
- NOTE:** Both sides of the cold end header box are negative. However, the (+) port reads less negative pressure than the (-) port.

**Figure 13. Measuring Pressure Differential**

# Service Information

**Table 7.**

<b>Problem</b>	<b>Corrective Action</b>
Pressure switch stuck closed	Check that the pressure switch is open without the combustion air inducer operating. Replace if defective.
Pressure switch does not close due to obstruction in vent pipe.	Check for restricted vent. Remove all blockage. Check for proper vent sizing. See <b>Table 13</b> .
Pressure switch does not close due to incorrect routing of the pressure switch tubing.	Check that the pressure switch tubing is correctly routed. Correctly route pressure switch line.
Pressure switch does not close due to obstructions in the pressure switch line.	Remove any obstructions from the pressure switch line and/or taps.
Pressure switch tubing damaged.	Check pressure switch tubing for leaks. Replace damaged tubing if necessary.
Condensate in pressure switch tubing.	Check pressure switch tubing for condensate. Remove condensate from tubing.
Pressure switch does not close due to a low differential pressure across the pressure switch.	Check the differential pressure across the pressure switch. Check for restricted inlet vent. Remove all blockage. Check for proper vent sizing and run length.
Wrong pressure switch installed in the unit, or pressure switch is out of calibration	Check that the correct pressure switch is installed in the unit. Replace pressure switch if necessary.
Miswiring of furnace or improper connections at pressure switch.	Check for correct wiring and loose connections. Correct wiring and/or replace any loose connections.
Pressure switch failure.	If all the above modes of failure have been checked, the pressure switch may have failed. Replace pressure switch and determine if unit will operate.
Damaged condensate trap.	Check trap for any cracks or damage and replace if necessary.
Cold end header box does not drain properly.	Check that the furnace is set properly with a slight tilt (0 - 1/2") towards the front if necessary. See furnace installation instruction.
Air leakage around the combustion air inducer gasket.	Check gasket and replace if necessary.
Air leakage around the cold end header box gasket.	Check gasket and replace if necessary.
Damaged cold end header box tubing.	Check tubing and replace if necessary.

# Service Information

## C- Blower Compartment

**▲IMPORTANT** Each blower is statically and dynamically balanced as an assembly before installation in the unit.

NF96U\*\*\*S\*\*R units are equipped with a constant torque ECM motor. It has a DC motor coupled to an electronic control module both contained in the same motor housing. The motor is programmed to provide constant torque at each of the five selectable speed taps. Each tap requires 24 volts to energize.

### Input Voltage Requirements

The circuit is designed to be operated with AC voltage. To enable a tap requires 12 to 33VAC. Expected current draw will be less than 20mA.

### Troubleshooting

Troubleshooting the motor is an easy process. Follow steps below.

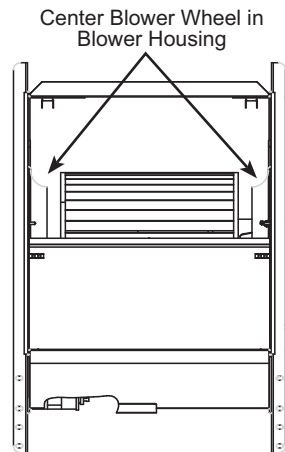
1. Shut off power to unit.
2. Remove input connectors J48 and J49 motor. See **Figure 17** for troubleshooting procedure.

If correct voltage is present in tests 1 and 2 and motor is not operating properly, replace motor. The motor is not field repairable.

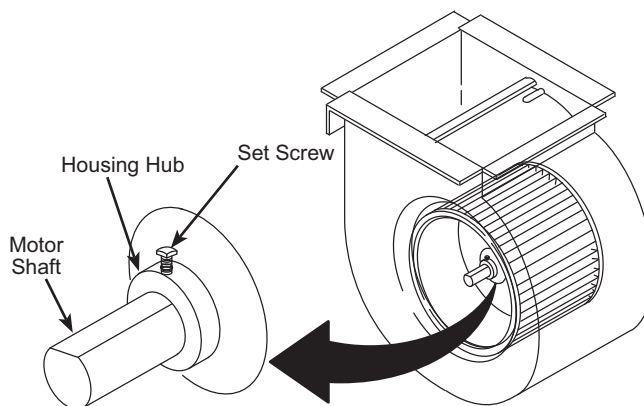
If replacing the indoor blower motor or blower wheel is necessary, placement is critical. The blower wheel must be centered in the blower housing as shown in **Figure 14**. When replacing the indoor blower motor the set screw must be aligned and tightened with the motor shaft as shown in **Figure 15**.

### 9. Secondary Limit Controls

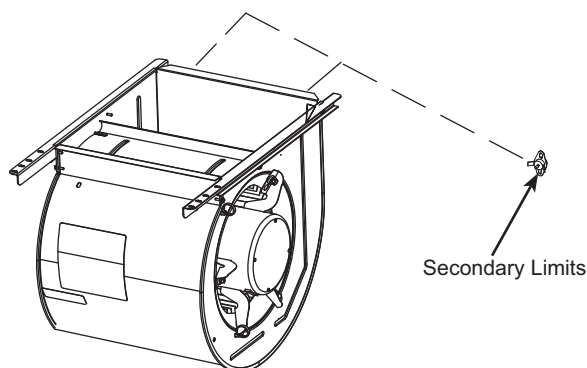
The secondary limit is located in the blower compartment on the back side of the blower housing. See **Figure 16**. When excess heat is sensed in the blower compartment, the limit will open. If the limit is open, the furnace control energizes the supply air blower and closes the gas valve. The limit automatically resets when unit temperature returns to normal. The secondary limit cannot be adjusted.



**Figure 14. Blower Wheel Replacement**

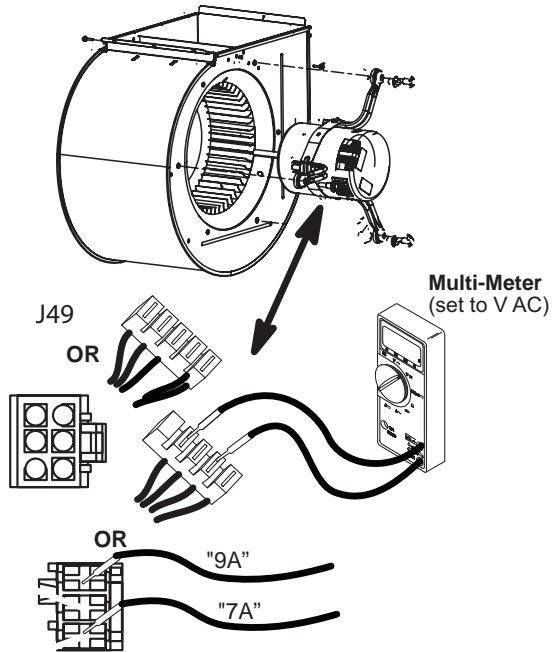


**Figure 15.**



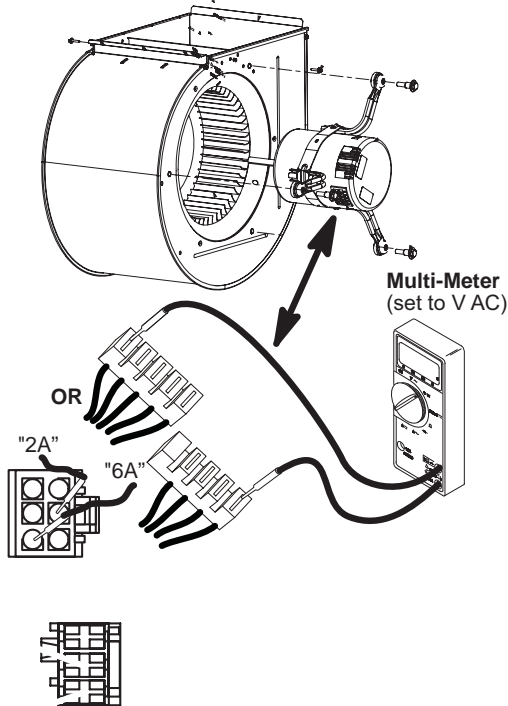
**Figure 16. Secondary Limit Control**

# Service Information

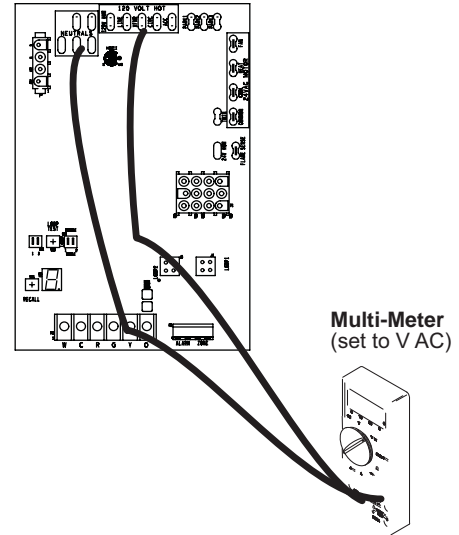


**Test 1** - Turn power on to unit. Check for 120 volts across terminals "L" and "N" or terminals "7A" and "9A" of connector J48. If voltage is present continue to test 2. If voltage is not present, problem may be upstream of J48. Proceed to **Test 3**.

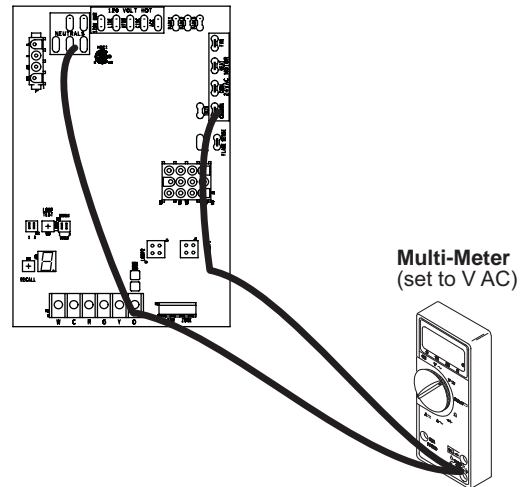
OR



**Test 2** - Switch thermostat to **CONTINUOUS FAN MODE**. For units using 4 and 5 position connector blocks, test for 24 volts terminal "C" of J48 and the tap used for continuous fan on J49 (1, 2, 3, 4 or 5). For units using 3 and 6 position connectors, test for 24 volts between pin "6A" and the pin used for continuous fan on connector J49 (1., 2, 3, 4 or 5).



**Test 3** (if necessary) - **NOTE** - Ignition control illustration is typical. Check for 120 volts across terminals "L1" and "Neutrals" on the integrated control. If voltage is present, problem is with the harness. If voltage is not present problem may be may be with the integrated control.



**Test 4** (if necessary) - **NOTE** - Ignition control illustration is typical. Check for 24 volts across terminals "24 COM" and the "active speed tap" on the integrated control. If voltage is present, problem is with the harness. If voltage is not present problem may be may be with the integrated control.

Figure 17.

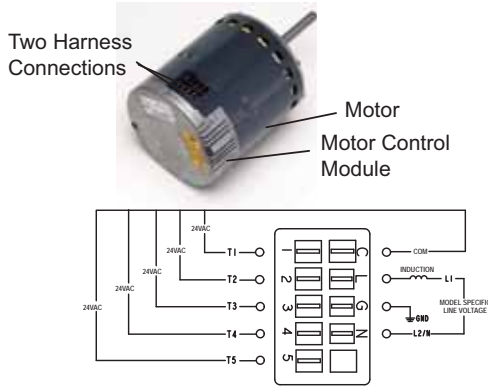
# Service Information

## Replacing the Motor Module

**NOTE** - Not all motors have field replaceable control modules. Only motors that utilize a 4 pin power connector and 5 pin signal connector as shown below may have replaceable controls. Motors that use a 3 pin power connector and 6 pin signal connector do not have field replaceable control modules. In the event of failure, the entire motor must be replaced.

- 1 - Disconnect electrical power to unit.
- 2 - Remove unit access panel.
- 3 - Unplug the two harnesses from the motor control module. See **Figure 18**.

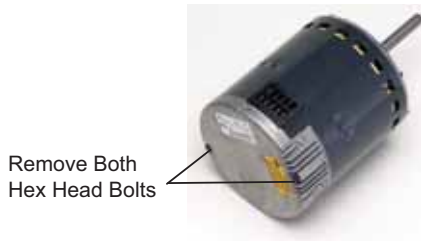
### Unplug the Two Harness Connection



**Figure 18.**

- 4 - Remove the two hex head bolts securing the motor control module to the motor (**Figure 19**).

### Remove the Hex Head Bolts



**Figure 19.**

- 5 - Slide the motor control module away from the motor to access and disconnect the internal three wire connector. It is not necessary to remove blower motor itself. Set both hex head bolts aside.

### Testing the Motor (Figure 20)

If any motor fails the below tests, do not install the new control module. The motor is defective and it also must be replaced. The new control can fail if placed on a defective motor.

- 1 - Using an ohmmeter check the resistance from any one of the motor connector pins to the aluminum end plate of the motor. This resistance should be greater than 100k ohms.

- 2 - Check the resistances between each of the three motor connector pins. These should all read approximately the same resistance within an ohm.
- 3 - Check to see if the blower wheel spins freely.

### Motor Test



**Figure 20.**

**Table 8.**

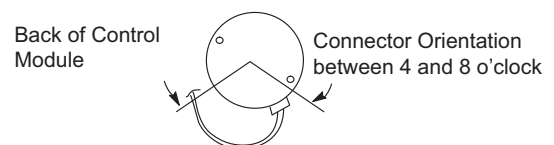
Scale	Measurement range in words	ohms
2M	two megohm-two million ohms	0 - 2,000,000
200 K	two hundred kilo-ohm-two hundred thousand ohms	0 - 200,000
20 K	twenty kilo-ohm-twenty thousand ohms	0 - 20,000
2 K	two kilo-ohm two-thousand ohms	0 - 2,000
200	two hundred ohms	0 - 200

### Motor Module Installation

All replacement motor control modules look similar; however, each module is designed for a specific motor size. It is very important to make sure that you are using the correct replacement motor control module. **USE OF THE WRONG MOTOR CONTROL MODULE MAY RESULT IN UNEXPECTED UNIT OPERATION.**

- 1 - Verify electrical power to unit is disconnected.
- 2 - Connect three-wire harness from motor to control module.
- 3 - Mount new motor control module to motor using two hex head bolts removed in **Figure 10**. Torque bolts to 22 inch pounds or 1/16th clock wise turn.
- 4 - Reconnect the two harnesses to the motor control module.
- 5 - The electrical connectors of the motor should be facing down to form a drip loop (**Figure 19**). This will direct moisture away from the motor and its electric connections on the motor.

### Drip Loop



**Figure 21.**

# Service Information

## PLACEMENT AND INSTALLATION

### Pipe & Fittings Specifications

All pipe, fittings, primer and solvent cement must conform with American National Standard Institute and the American Society for Testing and Materials (ANSI/ASTM) standards. The solvent shall be free flowing and contain no lumps, undissolved particles or any foreign matter that adversely affects the joint strength or chemical resistance of the cement. The cement shall show no gelation, stratification, or separation that cannot be removed by stirring. Refer to **Table 9** for approved piping and fitting materials.

**Table 9.**

<b>PIPING AND FITTINGS SPECIFICATIONS</b>	
Schedule 40 PVC (Pipe)	D1785
Schedule 40 PVC (Fittings)	D2466
Schedule 40 CPVC (Pipe)	F441
Schedule 40 CPVC (Fittings)	F438
SDR-21 PVC or SDR-26 PVC (Pipe)	D2241
SDR-21 CPVC or SDR-26 CPVC (Pipe)	F442
Schedule 40 ABS (Pipe)	D1527
Schedule 40 ABS (Fittings)	D2468
ABS-DWV (Drain Waste & Vent) (Pipe & Fittings)	D2661
PVC-DWV (Drain Waste & Vent) Pipe & Fittings)	D2665
<b>PRIMER &amp; SOLVENT CEMENT</b>	<b>ASTM SPECIFICATION</b>
PVC & CPVC Primer	F656
PVC Solvent Cement	D2564
CPVC Solvent Cement	F493
ABS Solvent Cement	D2235
PVC/CPVC/ABS All Purpose Cement For Fittings & Pipe of the same material	D2564, D2235, F493
ABS to PVC or CPVC Transition Solvent Cement	D3138
<b>CANADA PIPE &amp; FITTING &amp; SOLVENT CEMENT</b>	<b>MARKING</b>
PVC & CPVC Pipe and Fittings	ULCS636
PVC & CPVC Solvent Cement	
ABS to PVC or CPVC Transition Cement	
POLYPROPYLENE VENTING SYSTEM	
PolyPro® by Duravent	
InnoFlue® by Centrotherm	
<b>UL 1738 CERTIFIED GAS VENTING SYSTEM</b>	
IPEX System1738 Schedule 40 PVC Pipes and Fittings	UL1738
IPEX System1738 PVC FGV Cement & Primer	

\* Not approved as of 12-1-2022

### ▲ IMPORTANT

Exhaust and intake connections are made of PVC. Use PVC primer and solvent cement when using PVC vent pipe. When using ABS vent pipe, use transitional solvent cement to make connections to the PVC fittings in the unit.

### ▲ CAUTION

Solvent cements for plastic pipe are flammable liquids and should be kept away from all sources of ignition. Do not use excessive amounts of solvent cement when making joints. Good ventilation should be maintained to reduce fire hazard and to minimize breathing of solvent vapors. Avoid contact of cement with skin and eyes.

Use PVC primer and solvent cement or ABS solvent cement meeting ASTM specifications, refer to **Table 10**. As an alternate, use all purpose cement, to bond ABS, PVC, or CPVC pipe when using fittings and pipe made of the same materials. Use transition solvent cement when bonding ABS to either PVC or CPVC.

Low temperature solvent cement is recommended during cooler weather. Metal or plastic strapping may be used for vent pipe hangers. Uniformly apply a liberal coat of PVC primer for PVC or use a clean dry cloth for ABS to clean inside socket surface of fitting and male end of pipe to depth of fitting socket.

**Canadian Applications Only** - Pipe, fittings, primer and solvent cement used to vent (exhaust) this appliance must be certified to ULC S636 and supplied by a single manufacturer as part of an approved vent (exhaust) system. In addition, the first three feet of vent pipe from the furnace flue collar must be accessible for inspection.

# Service Information

Table 10. Outdoor Termination Kits

Capacity	Vent Pipe Dia. (in.)	Standard			<sup>6</sup> Concentric		
		Outdoor Exhaust Accelerator requirements for field provided terminations		Flush Mount Kit	1-1/2" Concentric Kit	2" Concentric Kit	3" Concentric Kit
		<sup>3</sup> Exhaust Accelerator (Dia. X Length)	<sup>3</sup> Exhaust Accelerator (Dia. X Length)	<sup>2</sup> 51W11	<sup>4</sup> 71M80	<sup>5</sup> 69M29	<sup>5</sup> 60L46
		1-1/2 X 12"	2 X 12"				
045	<sup>1</sup> 1-1/2	NO	NO	YES	YES	NO	NO
	2	YES	NO	YES	YES	NO	NO
	2-1/2	YES	NO	YES	YES	NO	NO
	3	YES	NO	YES	YES	NO	NO
070	<sup>1</sup> 1-1/2	NO	NO	YES	YES	NO	NO
	2	YES	NO	YES	YES	NO	NO
	2-1/2	YES	NO	YES	YES	NO	NO
	3	YES	NO	YES	YES	NO	NO
090	2	NO	NO	YES	NO	YES	YES
	2-1/2	NO	YES	YES	NO	YES	YES
	3	NO	YES	YES	NO	YES	YES
110	2	NO	NO	YES	NO	YES	YES
	2-1/2	NO	YES	YES	NO	YES	YES
	3	NO	YES	YES	NO	YES	YES
135	3	NO	YES	YES	NO	YES	YES

**NOTE: ALL KITS MUST BE PROPERLY INSTALLED ACCORDING TO KIT INSTRUCTIONS**

- 2" pipe to 1-1/2" reducer required to connect 1-1/2" vent pipe to furnace and must be field provided.
- Flush mount kit 51W11 includes a 1-1/2" outdoor exhaust accelerator, which is required when used with 045, 070, and 090 input models. The flush mount kit may be installed with 2", 2-1/2" (with provided reducer) or 3" vent pipe. When using 1-1/2" pipe, transition to 2" pipe prior to the installation of the flush mount kit.
- Field provided or field fabricated termination require use of a field provided exhaust accelerator as defined in the table.
- Concentric kit 71M80 includes a 1-1/2" outdoor accelerator which must be installed on the exhaust outlet when used with 045 and 070 input models.
- No Accelerator is required for kits 69M29 or 60L46.
- When the vent/intake diameters are different from the concentric vent kit size, field provided transitions must be used.

## Joint Cementing Procedure

All cementing of joints should be done according to the specifications outlined in ASTM D 2855.

**⚠ DANGER DANGER OF EXPLOSION!**

Fumes from PVC glue may ignite during system check. Allow fumes to dissipate for at least 5 minutes before placing unit into operation.

- Measure and cut vent pipe to desired length.
- Debur and chamfer end of pipe, removing any ridges or rough edges. If end is not chamfered, edge of pipe may remove cement from fitting socket and result in a leaking joint.

**NOTE:** Check the inside of vent pipe thoroughly for any obstruction that may alter furnace operation.

- Clean and dry surfaces to be joined.
- Test fit joint and mark depth of fitting on outside of pipe.
- Uniformly apply a liberal coat of PVC primer for PVC or use a clean dry cloth for ABS to clean inside socket surface of fitting and male end of pipe to depth of fitting socket.
 

**NOTE:** Time is critical at this stage. Do not allow primer to dry before applying cement.
- Promptly apply solvent cement to end of pipe and inside socket surface of fitting. Cement should be applied lightly but uniformly to inside of socket. Take care to keep excess cement out of socket. Apply second coat to end of pipe.

# Service Information

## Joint Cementing Procedure (Cont.)

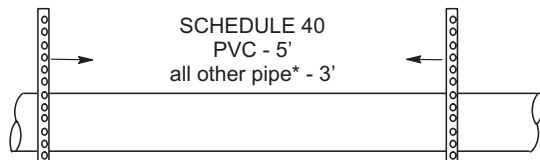
7. Immediately after applying last coat of cement to pipe, and while both inside socket surface and end of pipe are wet with cement, forcefully insert end of pipe into socket until it bottoms out. Turn PVC pipe 1/4 turn during assembly (but not after pipe is fully inserted) to distribute cement evenly. DO NOT turn ABS pipe.

**NOTE:** Assembly should be completed within 20 seconds after last application of cement. Hammer blows should not be used when inserting pipe.

8. After assembly, wipe excess cement from pipe at end of fitting socket. A properly made joint will show a bead around its entire perimeter. Any gaps may indicate an improper assembly due to insufficient solvent.

9. Handle joints carefully until completely set.

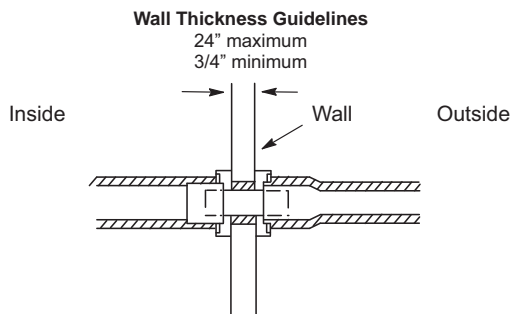
## Venting Practices



\* See Piping and Fittings Specifications table

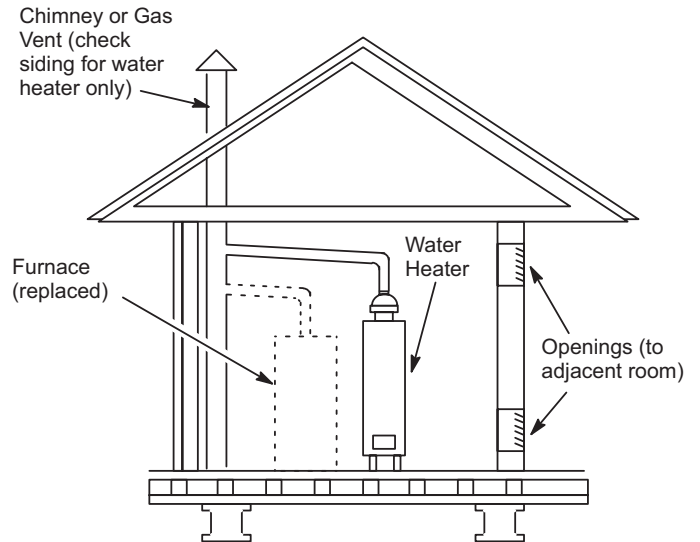
**NOTE:** Vertical support guidelines: Recommend following the guidelines in the International Plumbing code for PVC.

**NOTE:** Isolate piping at the point where it exits the outside wall or roof in order to prevent transmission of vibration to the structure.



**Figure 22. Horizontal Piping Support Guidelines**

1. In areas where piping penetrates joists or interior walls, hole must be large enough to allow clearance on all sides of pipe through center of hole using a hanger.
2. When furnace is installed in a residence where unit is shut down for an extended period of time, such as a vacation home, make provisions for draining condensate collection trap and lines.



If replacing a furnace which was commonly vented with another gas appliance, the size of the existing vent pipe for that gas appliance must be checked. Without the heat of the original furnace flue products, the existing vent pipe is probably oversized for the single water heater or other appliance. The vent should be checked for proper draw with the remaining appliance.

**Figure 23. REPLACING FURNACE THAT WAS PART OF A COMMON VENT SYSTEM**

## Exhaust Piping (Figure 26 & Figure 27)

Route piping to outside of structure. Continue with installation following instructions given in piping termination section.

**CAUTION** Do not discharge exhaust into an existing stack or stack that also serves another gas appliance. If vertical discharge through an existing unused stack is required, insert PVC pipe inside the stack until the end is even with the top or outlet end of the metal stack.

**CAUTION** The exhaust vent pipe operates under positive pressure and must be completely sealed to prevent leakage of combustion products into the living space.

# Service Information

## Vent Piping Guidelines

**NOTE:** GE Appliances has approved the use of DuraVent® and Centrotherm manufactured vent pipe and terminations as an option to PVC. When using the PolyPro® by DuraVent or InnoFlue® by Centrotherm venting system the vent pipe requirements stated in the unit installation instruction – minimum & maximum vent lengths, termination clearances, etc. – apply and must be followed. Follow the instructions provided with PoyPro by DuraVent and InnoFlue by Centrotherm venting system for assembly or if requirements are more restrictive. The PolyPro by Duravent and InnoFlue by Centrotherm venting system must also follow the uninsulated and unconditioned space criteria listed in **Table 15**.

The NF96U\*\*\*S\*\*R can be installed as either a Non-Direct Vent or a Direct Vent gas central furnace.

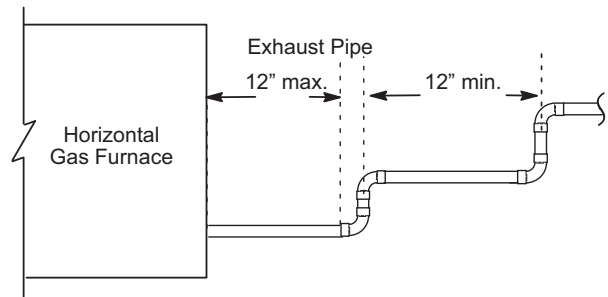
**NOTE:** In Non-Direct Vent installations, combustion air is taken from indoors and flue gases are discharged outdoors. In Direct Vent installations, combustion air is taken from outdoors and flue gases are discharged outdoors.

Intake and exhaust pipe sizing -- Size pipe according to **Table 11** (minimum pipe lengths) and **Table 12** (maximum pipe lengths). Count all elbows inside and outside the home. **Table 13** lists maximum pipe lengths for furnaces installed in a closet or basement using ventilated attic or crawl space for intake air.

Regardless of the diameter of pipe used, the standard roof and wall terminations described in section Exhaust Piping Terminations should be used. Exhaust vent termination pipe is sized to optimize the velocity of the exhaust gas as it exits the termination. Refer to **Table 15**.

In some applications which permit the use of several different sizes of vent pipe, a combination vent pipe may be used. Contact GE Appliances for assistance in sizing vent pipe in these applications.

**NOTE:** The exhaust collar on all models is sized to accommodate 2" Schedule 40 vent pipe. In horizontal applications, any transition to exhaust pipe larger than 2" must be made in vertical runs of the pipe. Therefore a 2" elbow must be added before the pipe is transitioned to any size larger than 2". This elbow must be added to the elbow count used to determine acceptable vent lengths. Contact GE Appliances for more information concerning sizing of vent systems which include multiple pipe sizes.



**NOTE:** All horizontal runs of exhaust pipe must slope back toward unit. A minimum of 1/4" (6mm) drop for each 12" (305mm) of horizontal run is mandatory for drainage.

**NOTE:** Exhaust pipe MUST be glued to furnace exhaust fitting, unless the optional glueless vent adapter kit 17H92 is used.

**NOTE:** Exhaust piping should be checked carefully to make sure there are no sags or low spots.

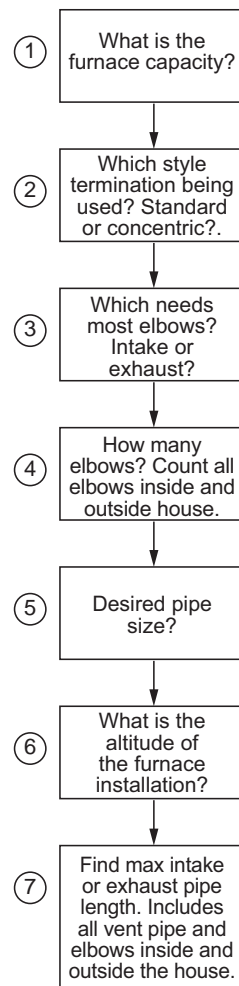
**Figure 24. Horizontal Installation Offset Requirements**

**Table 11. Minimum Vent Pipe Lengths**

NF96U***S**R	Model MIN. VENT LENGTH*
045, -070, -090, 110, 135	15 ft. or 5 ft. plus 2 elbows or 10 ft. plus 1 elbow

\*Any approved termination may be added to the minimum length listed. Two 45 degree elbows are the equivalent of one 90 degree elbow.

**Figure 25. Piping Size Process**



# Service Information

## Vent Piping Guidelines (Cont.)

### ▲ IMPORTANT

Do not use screens or perforated metal in exhaust or intake terminations. Doing so will cause freeze-ups and may block the terminations.

**Table 12. Maximum Allowable Intake or Exhaust Vent Length in Feet**

**NOTE:** Size intake and exhaust pipe length separately. Values in table are for Intake OR Exhaust, not combined total. Both Intake and Exhaust must be same pipe size.

**NOTE:** Additional vent pipe and elbows used to terminate the vent pipe outside the structure must be included in the total vent length calculation.

Standard Termination at Elevation 0 - 2000 ft																				
No. Of 90° Elbows	1-1/2" Pipe					2" Pipe					2-1/2" Pipe					3" Pipe				
	Model					Model					Model					Model				
	045	070	090	110	135	045	070	090	110	135	045	070	090	110	135	045	070	090	110	1135
1	20	15	n/a	n/a	n/a	81	66	44	24	n/a	115	115	93	8	n/a	138	137	118	118	80
2	15	10				76	61	39	19		110	110	88	53		133	132	113	113	75
3	10	71				56	34	14	105		105	83	48	128		127	108	108	70	
4	66	51				29	100	100	78		43	123	122	103		103	65			
5	61	46				24	95	95	73		38	118	117	98		98	60			
6	56	41				19	90	90	68		33	113	112	93		93	55			
7	51	36				14	85	85	63		28	108	107	88		88	50			
8	46	31				n/a	80	80	58		23	103	102	83		83	45			
9	41	26					75	75	53		18	98	97	78		78	40			
10	36	21					70	70	48		13	93	92	73		73	35			

1 Contact your local FTC if more than 85ft of venting is needed for the NF96U135S5DR

Standard Termination at Elevation 20001 - 10,000 ft															
No. Of 90° Elbows	2" Pipe					2-1/2" Pipe					3" Pipe				
	Model					Model					Model				
	045	070	090	110	135	045	070	090	110	135	045	070	090	110	1135
1	81	35	20	n/a	n/a	115	110	67	53	n/a	138	137	118	118	80
2	76	30	15			110	105	62	48		133	132	113	113	75
3	71	25	10			105	100	57	43		128	127	108	108	70
4	66	20	100			95	52	38	123		122	103	103	65	
5	61	15	95			90	47	33	118		117	98	98	60	
6	56	10	90			85	42	28	113		112	93	93	55	
7	51	n/a	n/a			85	80	37	23		108	107	88	88	50
8	46					80	75	32	18		103	102	83	83	45
9	41					75	70	27	13		98	97	78	78	40
10	36					70	65	22	n/a		93	92	73	73	35

1 Contact your local FTC if more than 85ft of venting is needed for the NF96U135S5DR

# Service Information

## Vent Piping Guidelines (Cont.)

Table 12. (Cont.)

**NOTE:** Size intake and exhaust pipe length separately. Values in table are for Intake OR Exhaust, not combined total. Both Intake and Exhaust must be same pipe size.

**NOTE:** Additional vent pipe and elbows used to terminate the vent pipe outside the structure must be included in the total vent length calculation.

Concentric Termination at Elevation 0 - 2000 ft																				
No. Of 90° Elbows	1-1/2" Pipe					2" Pipe					2-1/2" Pipe					3" Pipe				
	Model					Model					Model					Model				
	045	070	090	110	135	045	070	090	110	135	045	070	090	110	135	045	070	090	110	1135
1	15	10				73	58	42	22		105	105	89	54		121	121	114	114	70
2	10					68	53	37	17		100	100	84	49		116	116	109	109	65
3						63	48	32	12		95	95	79	44		111	111	104	104	60
4						58	43	27			90	90	74	39		106	106	99	99	55
5						53	38	22			85	85	69	34		101	101	94	94	50
6	n/a	n/a	n/a	n/a	n/a	48	33	17			80	80	64	29		96	96	89	89	45
7						43	28	12	n/a		75	75	59	24		91	91	84	84	40
8						38	23				70	70	54	19		86	86	79	79	35
9						33	18	n/a			65	65	49	14		81	81	74	74	30
10						28	13				60	60	44	n/a		76	76	69	69	25

Standard Termination at Elevation 20001 - 10,000 ft															
No. Of 90° Elbows	2" Pipe					2-1/2" Pipe					3" Pipe				
	Model					Model					Model				
	045	070	090	110	135	045	070	090	110	135	045	070	090	110	1135
1	81	35	20			115	110	67	53		138	137	118	118	80
2	76	30	15			110	105	62	48		133	132	113	113	75
3	71	25	10			105	100	57	43		128	127	108	108	70
4	66	20				100	95	52	38		123	122	103	103	65
5	61	15				95	90	47	33		118	117	98	98	60
6	56	10			n/a	90	85	42	28		113	112	93	93	55
7	51					85	80	37	23		108	107	88	88	50
8	46					80	75	32	18		103	102	83	83	45
9	41					75	70	27	13		98	97	78	78	40
10	36					70	65	22	n/a		93	92	73	73	35

# Service Information

## Vent Piping Guidelines (Cont.)

**Table 13. Maximum Allowable Exhaust Vent Lengths With Furnace Installed in a Closet or Basement Using Ventilated Attic or Crawl Space For Intake Air in Feet**

**NOTE:** Additional vent pipe and elbows used to terminate the vent pipe outside the structure must be included in the total vent length calculation.

Standard Termination at Elevation 0 - 2000 ft																				
No. Of 90° Elbows	1-1/2" Pipe					2" Pipe					2-1/2" Pipe					3" Pipe				
	Model					Model					Model					Model				
	045	070	090	110	135	045	070	090	110	135	045	070	090	110	135	045	070	090	110	1135
1	15	10				71	56	34	14		100	100	78	43		118	117	98	98	60
2	10					66	51	29	9		95	95	73	38		113	112	93	93	55
3						61	46	24			90	90	68	33		108	107	88	88	50
4						56	41	19			85	85	63	28		103	102	83	83	45
5						51	36	14			80	80	58	23		98	97	78	78	40
6						46	31	9			75	75	53	18		93	92	73	73	35
7	n/a	n/a	n/a	n/a	n/a	41	26				70	70	48	13		88	87	68	68	30
8						36	21				65	65	43			83	82	63	63	25
9						31	16				60	60	38	n/a		78	77	58	58	20
10						26	11				55	55	33			73	72	53	53	15

Standard Termination at Elevation 20001 - 10,000 ft															
No. Of 90° Elbows	2" Pipe					2-1/2" Pipe					3" Pipe				
	Model					Model					Model				
	045	070	090	110	135	045	070	090	110	135	045	070	090	110	1135
1	71	30	15			100	96	53	38		118	117	98	98	60
2	66	25	10			95	91	48	33		113	112	93	93	55
3	61	20				90	86	43	28		108	107	88	88	50
4	56	15				85	81	38	23		103	102	83	83	45
5	51	10				80	76	33	18		98	97	78	78	40
6	46					75	71	28	13		93	92	73	73	35
7	41					70	66	23			88	87	68	68	30
8	36					65	61	18			83	82	63	63	25
9	31					60	56	13			78	77	58	58	20
10	26					55	51	n/a			73	72	53	53	15

# Service Information

## Vent Piping Guidelines (Cont.)

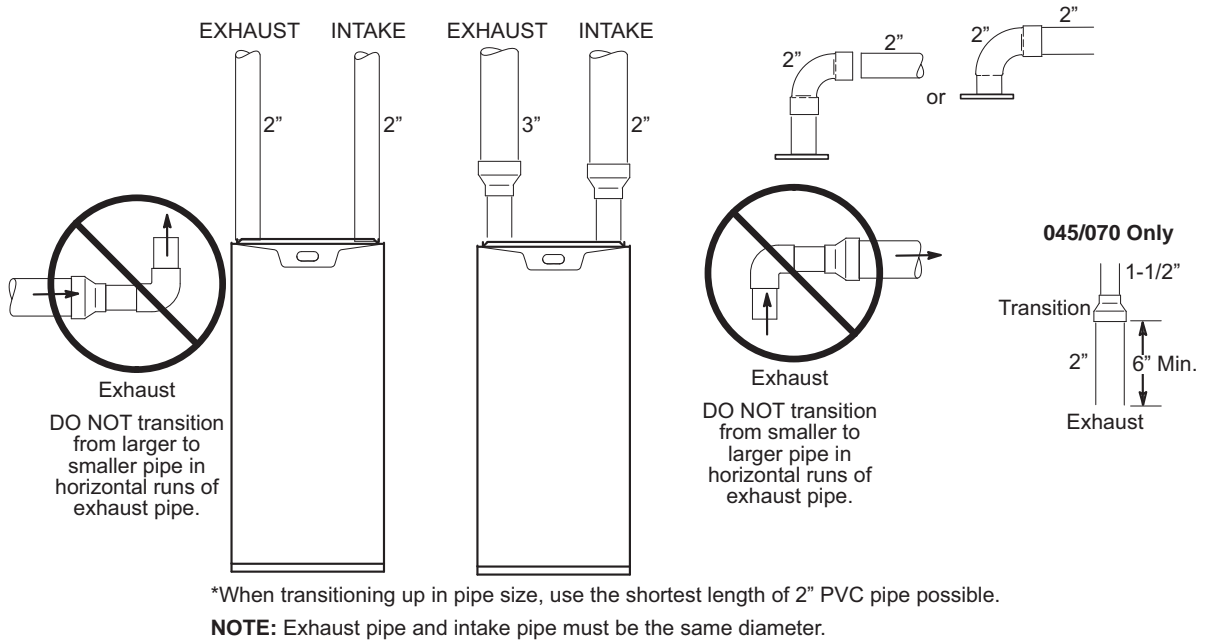


Figure 26. Typical Exhaust and Intake Pipe Connections in Upflow Direct or Non-Direct Vent Applications

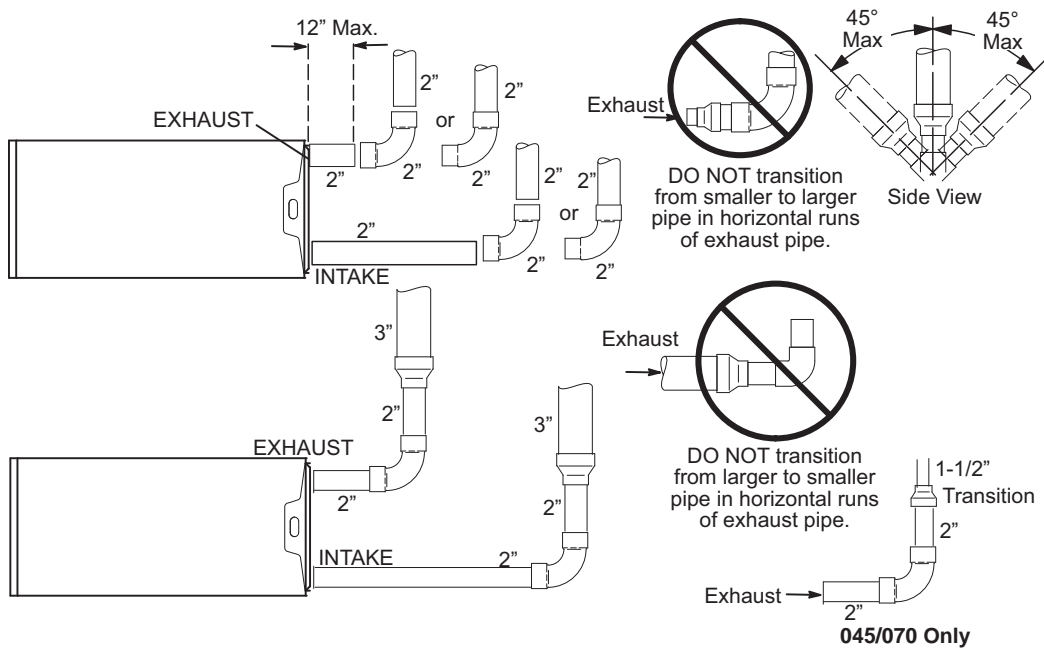


Figure 27. Typical Exhaust and Intake Pipe Connections in Horizontal Direct or Non-Direct Vent Applications (Right Hand Discharge Shown)

# Service Information

## Intake Piping

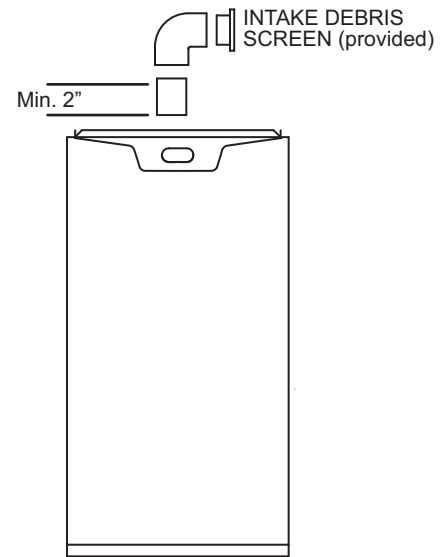
The NF96U\*\*\*S\*\*R furnace may be installed in either direct vent or non-direct vent applications. In non-direct vent applications, when intake air will be drawn into the furnace from the surrounding space, the indoor air quality must be considered and guidelines listed in Combustion, Dilution and Ventilation Air section must be followed.

Follow the next two steps when installing the unit in Direct Vent applications, where combustion air is taken from outdoors and flue gases are discharged outdoors. The provided air intake screen must not be used in direct vent applications (outdoors).

1. Use transition solvent cement or a sheet metal screw to secure the intake pipe to the inlet air connector.
2. Route piping to outside of structure. Continue with installation following instructions given in general guidelines for piping terminations and intake and exhaust piping terminations for direct vent sections. Refer to **Table 12** for pipe sizes.

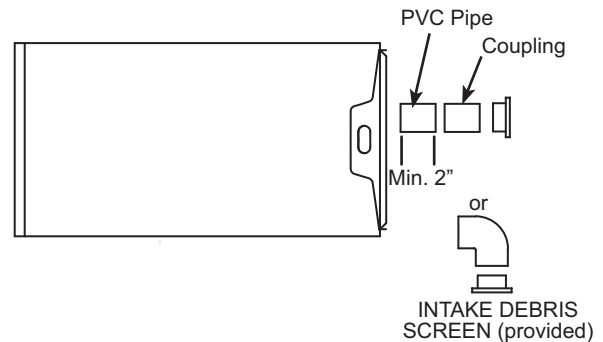
Follow the next two steps when installing the unit in Non-Direct Vent applications where combustion air is taken from indoors and flue gases are discharged outdoors.

1. Use field-provided materials and the factory-provided air intake screen to route the intake piping as shown in **Figure 28** and **Figure 29**. Maintain a minimum clearance of 3" (76mm) around the air intake opening. The air intake opening (with the protective screen) should always be directed forward or to either side in the upflow position, and either straight out or downward in the horizontal position. The air intake piping must not terminate too close to the flooring or a platform. Ensure that the intake air inlet will not be obstructed by loose insulation or other items that may clog the debris screen.
2. If intake air is drawn from a ventilated attic (**Figure 30**) or ventilated crawl space (**Figure 31**) the exhaust vent length must not exceed those listed in **Table 13**. If 3" diameter pipe is used, reduce to 2" diameter pipe at the termination point to accommodate the debris screen.
3. Use a sheet metal screw to secure the intake pipe to the connector, if desired.



**NOTE:** Debris screen and elbow may be rotated so that screen may be positioned to face forward or to either side.

**Figure 28. Typical Air in Take Pipe Connections Upflow Non-Direct Vent Applications**



**NOTE:** Debris screen may be positioned straight out (preferred) or with an elbow rotated to face down.

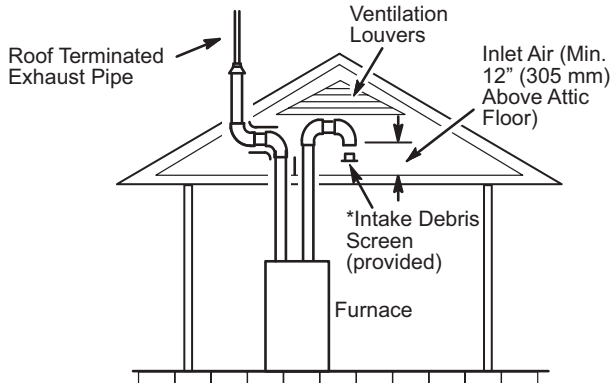
**Figure 29. Typical Air in Take Pipe Connections Horizontal Non-Direct Vent Applications (Horizontal Right-Hand Air Discharge Application Shown)**

# Service Information

## Intake Piping (Cont.)

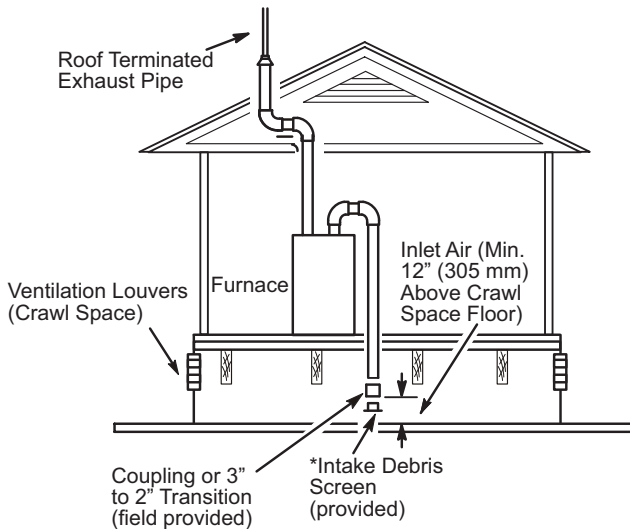
### CAUTION

If this unit is being installed in an application with combustion air coming in from a space serviced by an exhaust fan, power exhaust fan, or other device which may create a negative pressure in the space, take care when sizing the inlet air opening. The inlet air opening must be sized to accommodate the maximum volume of exhausted air as well as the maximum volume of combustion air required for all gas appliances serviced by this space.



**NOTE:** The inlet and outlet air openings shall each have a free area of at least one square inch per 4,000 Btu (645mm<sup>2</sup> per 1.17kW) per hour of the total input rating of all equipment in the enclosure.

**Figure 30. Equipment in Confined Space (Inlet Air from Ventilated Attic and Outlet Air to Outside)**



**NOTE:** The inlet and outlet air openings shall each have a free area of at least one square inch per 4,000 Btu (645mm<sup>2</sup> per 1.17kW) per hour of the total input rating of all equipment in the enclosure.

**Figure 31. Equipment in Confined Space (Inlet Air from Ventilated Crawl Space and Outlet Air to Outside)**

## General Guidelines for Vent Terminations

In Non-Direct Vent applications, combustion air is taken from indoors and the flue gases are discharged to the outdoors. The NF96U\*\*\*S\*\*R is then classified as a non-direct vent, Category IV gas furnace.

In Direct Vent applications, combustion air is taken from outdoors and the flue gases are discharged to the outdoors. The NF96U\*\*\*S\*\*R is then classified as a direct vent, Category IV gas furnace.

In both Non-Direct Vent and Direct Vent applications, the vent termination is limited by local building codes. In the absence of local codes, refer to the current National Fuel Gas Code ANSI Z223-1/NFPA 54 in U.S.A., and current CSA-B149 Natural Gas and Propane Installation Codes in Canada for details.

Position termination according to location given in **Figure 33** or **Figure 34**. In addition, position termination so it is free from any obstructions and 12" above the average snow accumulation.

At vent termination, care must be taken to maintain protective coatings over building materials (prolonged exposure to exhaust condensate can destroy protective coatings). It is recommended that the exhaust outlet not be located within 6 feet (1.8m) of an outdoor AC unit because the condensate can damage the painted coating.

**NOTE:** See **Table 14** for maximum allowed exhaust pipe length without insulation in unconditioned space during winter design temperatures below 32°F (0°C). If required exhaust pipe should be insulated with 1/2" (13mm) Armaflex or equivalent. In extreme cold climate areas, 3/4" (19mm) Armaflex or equivalent may be necessary. Insulation must be protected from deterioration. Armaflex with UV protection is permissible. Basements or other enclosed areas that are not exposed to the outdoor ambient temperature and are above 32°F (0°C) are to be considered conditioned spaces.

### IMPORTANT

Do not use screens or perforated metal in exhaust terminations. Doing so will cause freeze-ups and may block the terminations.

### IMPORTANT

#### For Canadian Installations Only:

In accordance to CSA International B149 installation codes, the minimum allowed distance between the combustion air intake inlet and the exhaust outlet of other appliances shall not be less than 12" (305mm).

# Service Information

**Table 14. Maximum Allowable Exhaust Vent Pipe Length (in ft.)<sup>3</sup> without Insulation in Unconditioned Space for Winter Design Temperatures Single - Stage High Efficiency Furnace**

Winter Design Temp <sup>1</sup> °F (°C)	Vent Pipe Diam	Unit Input Size									
		045		070		090		110		135	
		PVC	²PP	PVC	²PP	PVC	²PP	PVC	²PP	PVC	²PP
32 to 21 (0 to -6)	1-1/2 in	25	N/A	20	N/A	N/A	N/A	N/A	N/A	N/A	N/A
	2 in	18	16	31	28	50	48	30	30		
	2-1/2 in	13	N/A	24	N/A	42	N/A	56	N/A		
	3 in	9	9	18	18	35	35	47	47	42	42
20 to 1 (-7 to -17)	1-1/2 in	15	N/A	20	N/A	N/A	N/A	N/A	N/A	N/A	N/A
	2 in	9	8	18	16	32	29	30	30		
	2-1/2 in	5	N/A	13	N/A	24	N/A	34	N/A		
	3 in	1	1	8	8	19	19	26	26	23	23
0 to -20 (-18 to -29)	1-1/2 in	10	N/A	15	N/A	N/A	N/A	N/A	N/A	N/A	N/A
	2 in	5	3	12	10	22	19	30	27		
	2-1/2 in	1	N/A	7	N/A	15	N/A	22	N/A		
	3 in	N/A	N/A	2	2	10	10	16	16	13	13

1 Refer to 99% Minimum Design Temperature table provided in the current edition of the ASHRAE Fundamentals Handbook.

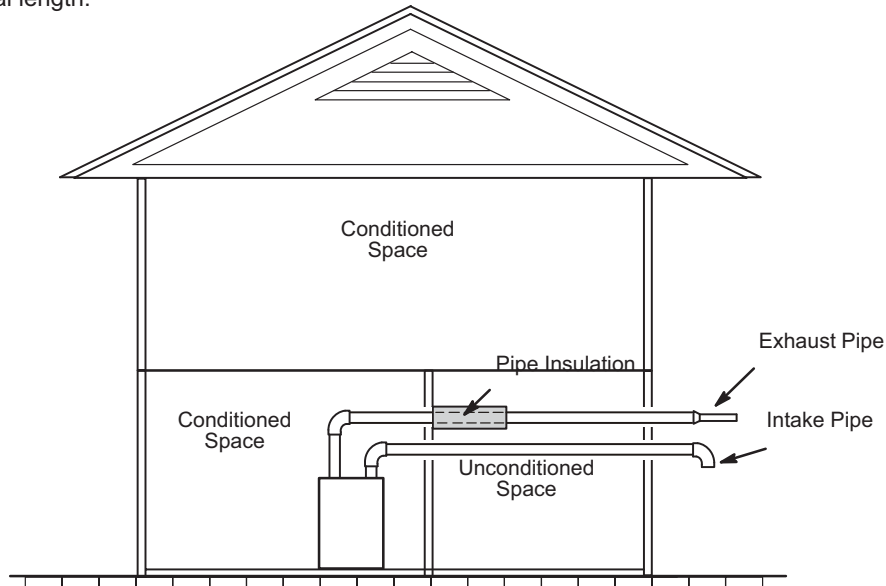
2 Poly-Propylene vent pipe (PP) by Duravent and Centrotherm.

**NOTE:** Concentric terminations are the equivalent of 5' and should be considered when measuring pipe length.

**NOTE:** Maximum uninsulated vent lengths listed may include the termination (vent pipe exterior to the structure) and cannot exceed 5 linear feet or the maximum allowable intake or exhaust vent length listed in table **Table 12** or **Table 14** which ever is less.

**NOTE:** If insulation is required in an unconditioned space, it must be located on the pipe closest to the furnace. See **Figure 32**.

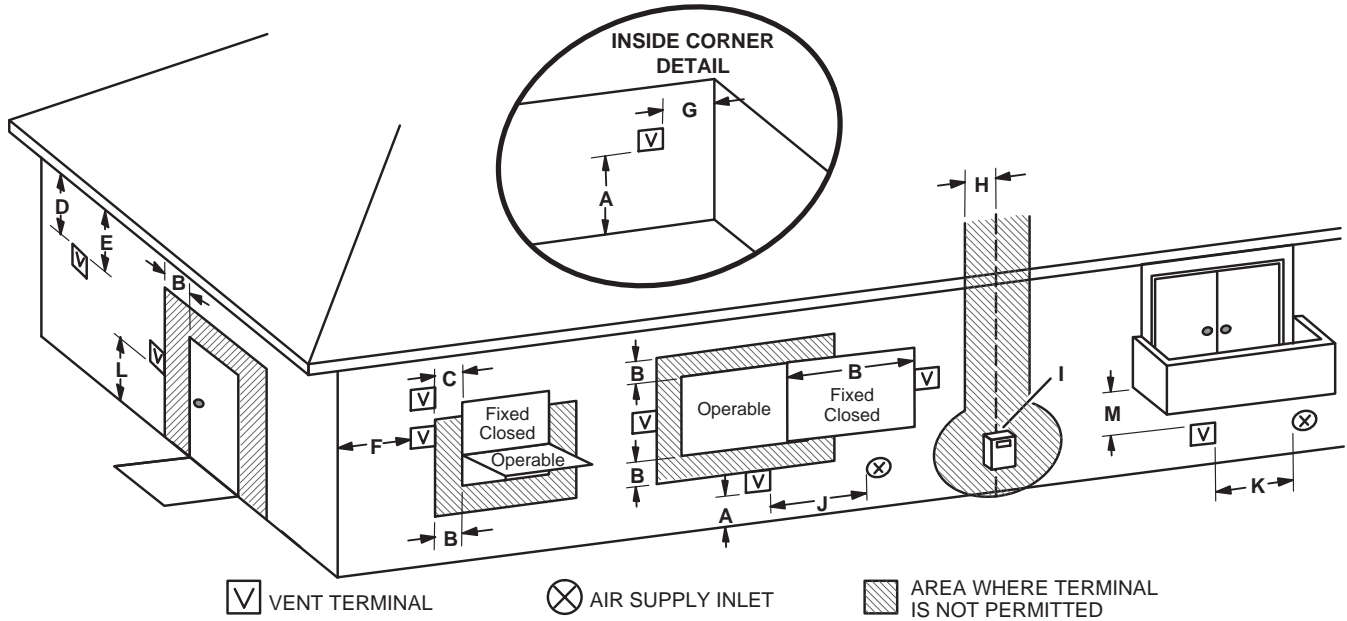
3 Vent length in the table is equivalent length. Each elbow is equivalent to 5ft of straight pipe and should be included when measuring total length.



**Figure 32.**

# Service Information

## VENT TERMINATION CLEARANCES FOR NON-DIRECT VENT INSTALLATIONS IN THE USA AND CANADA



	US Installations <sup>1</sup>	Canadian Installations <sup>2</sup>	
A =	Clearance above grade, veranda, porch, deck or balcony	12 inches (305mm) or 12 in. (305mm) above average snow accumulation.	12 inches (305mm) or 12 in. (305mm) above average snow accumulation.
B =	Clearance to window or door that may be opened	4 feet (1.2 m) below or to side of opening; 1 foot (30cm) above opening	6 inches (152mm) for appliances <10,000 Btuh (3kw), 12 inches (305mm) for appliances > 10,000 Btuh (3kw) and <100,000 Btuh (30kw), 36 inches (.9m) for appliances > 100,000 Btuh (30kw)
C =	Clearance to permanently closed window	* 12"	* 12"
D =	Vertical clearance to ventilated soffit located above the terminal within a horizontal distance of 2 feet (610 mm) from the center line of the terminal	* Equal to or greater than soffit depth.	* Equal to or greater than soffit depth.
E =	Clearance to unventilated soffit	* Equal to or greater than soffit depth.	* Equal to or greater than soffit depth.
F =	Clearance to outside corner	* No minimum to outside corner	* No minimum to outside corner
G =	Clearance to inside corner	*	*
H =	Clearance to each side of center line extended above meter / regulator assembly	* 3 feet (.9m) within a height 15 feet (4.5m) above the meter / regulator assembly	3 feet (.9m) within a height 15 feet (4.5m) above the meter / regulator assembly
I =	Clearance to service regulator vent outlet	* 3 feet (.9m)	3 feet (.9m)
J =	Clearance to non-mechanical air supply inlet to building or the combustion air inlet to any other appliance	4 feet (1.2 m) below or to side of opening; 1 foot (30 cm) above opening	6 inches (152mm) for appliances <10,000 Btuh (3kw), 12 inches (305mm) for appliances > 10,000 Btuh (3kw) and <100,000 Btuh (30kw), 36 inches (.9m) for appliances > 100,000 Btuh (30kw)
K =	Clearance to mechanical air supply inlet	3 feet (.9m) above if within 10 feet (3m) horizontally	6 feet (1.8m)
L =	Clearance above paved sidewalk or paved driveway located on public property	7 feet (2.1m)†	7 feet (2.1m)†
M =	Clearance under veranda, porch, deck or balcony	*12 inches (305mm)‡	12 inches (305mm)‡

<sup>1</sup> In accordance with the current ANSI Z223.1/NFPA 54 Natural Fuel Gas Code

<sup>2</sup> In accordance with the current CSA B149.1, Natural Gas and Propane Installation Code

† A vent shall not terminate directly above a sidewalk or paved driveway that is located between two single family dwellings and serves both dwellings.

‡ Permitted only if veranda, porch, deck or balcony is fully open on a minimum of two sides beneath the floor. GE Appliances recommends avoiding this location if possible.

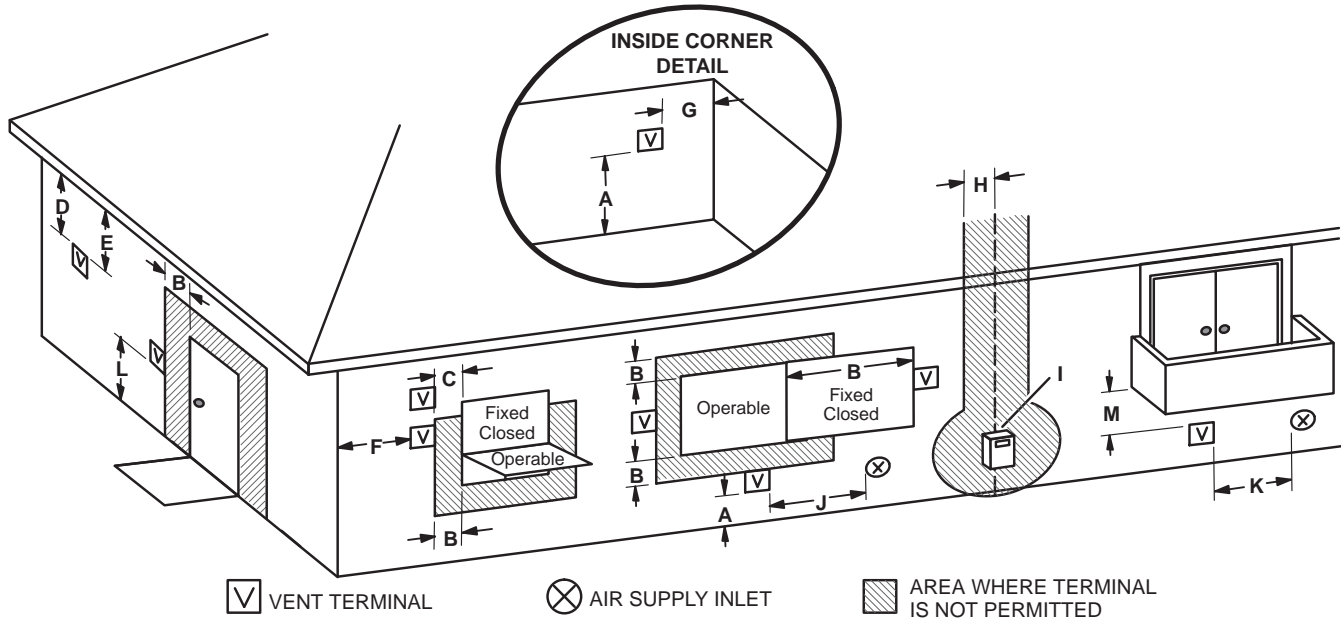
\*For clearances not specified in ANSI Z223.1/NFPA 54 or CSA B149.1, clearance will be in accordance with local installation codes and the requirements of the gas supplier and these installation instructions."

**NOTE** - This figure is intended to illustrate clearance requirement and does not serve as a substitute for locally adopted installation codes.

Figure 33.

# Service Information

## VENT TERMINATION CLEARANCES FOR DIRECT VENT INSTALLATIONS IN THE US AND CANADA



	US Installations <sup>1</sup>	Canadian Installations <sup>2</sup>
A =	Clearance above grade, veranda, porch, deck or balcony	12 inches (305mm) or 12 in. (305mm) above average snow accumulation.
B =	Clearance to window or door that may be opened	6 inches (152mm) for appliances <10,000 Btuh (3kw), 9 inches (228mm) for appliances > 10,000 Btuh (3kw) and <50,000 Btuh (15 kw), 12 inches (305mm) for appliances > 50,000 Btuh (15kw)
C =	Clearance to permanently closed window	* 12"
D =	Vertical clearance to ventilated soffit located above the terminal within a horizontal distance of 2 feet (610mm) from the center line of the terminal	* Equal to or greater than soffit depth
E =	Clearance to unventilated soffit	* Equal to or greater than soffit depth
F =	Clearance to outside corner	* No minimum to outside corner
G =	Clearance to inside corner	*
H =	Clearance to each side of center line extended above meter / regulator assembly	3 feet (.9m) within a height 15 feet (4.5m) above the meter / regulator assembly
I =	Clearance to service regulator vent outlet	* 3 feet (.9m)
J =	Clearance to non-mechanical air supply inlet to building or the combustion air inlet to any other appliance	6 inches (152mm) for appliances <10,000 Btuh (3kw), 9 inches (228mm) for appliances > 10,000 Btuh (3kw) and <50,000 Btuh (15 kw), 12 inches (305mm) for appliances > 50,000 Btuh (15kw)
K =	Clearance to mechanical air supply inlet	3 feet (.9m) above if within 10 feet (3m) horizontally
L =	Clearance above paved sidewalk or paved driveway located on public property	* 7 feet (2.1m)
M =	Clearance under veranda, porch, deck or balcony	*12 inches (305mm)‡

<sup>1</sup> In accordance with the current ANSI Z223.1/NFPA 54 Natural Fuel Gas Code

<sup>2</sup> In accordance with the current CSA B149.1, Natural Gas and Propane Installation Code

† A vent shall not terminate directly above a sidewalk or paved driveway that is located between two single family dwellings and serves both dwellings.

‡ Permitted only if veranda, porch, deck or balcony is fully open on a minimum of two sides beneath the floor. GE Appliances recommends avoiding this location if possible.

\*For clearances not specified in ANSI Z223.1/NFPA 54 or CSA B149.1, clearance will be in accordance with local installation codes and the requirements of the gas supplier and these installation instructions."

**NOTE** - This figure is intended to illustrate clearance requirements and does not serve as a substitute for locally adopted installation codes.

Figure 34.

# Service Information

## Details of Intake and Exhaust Piping Terminations for Direct Vent Installations

**NOTE:** In Direct Vent installations, combustion air is taken from outdoors and flue gases are discharged to outdoors.

**NOTE:** Flue gas may be slightly acidic and may adversely affect some building materials. If any vent termination is used and the flue gasses may impinge on the building material, corrosion-resistant shield (minimum 24" square) should be used to protect the wall surface. If the optional tee is used, the protective shield is recommended. The shield should be constructed using wood, plastic, sheet metal or other suitable material. All seams, joints, cracks, etc. in the affected area should be sealed using an appropriate sealant. See **Figure 43**.

Intake and exhaust pipes may be routed either horizontally through an outside wall or vertically through the roof. In attic or closet installations, vertical termination through the roof is preferred. **Figure 35** through **Figure 42** shows typical terminations.

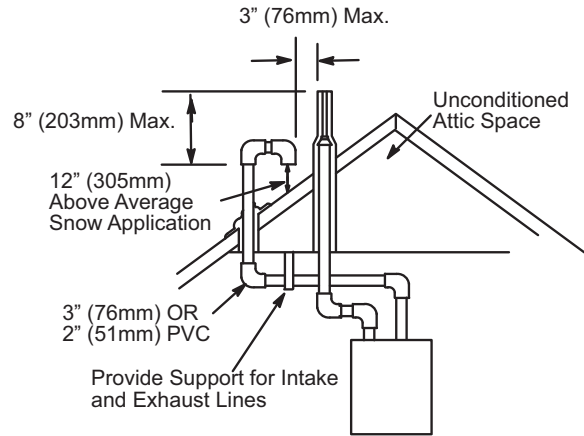
1. Intake and exhaust terminations are not required to be in the same pressure zone. You may exit the intake on one side of the structure and the exhaust on another side (**Figure 36**) you may exit the exhaust out the roof and the intake out the side of the structure (**Figure 37**).
2. Intake and exhaust pipes should be placed as close together as possible at termination end (refer to illustrations). Maximum separation is 3" (76mm) on roof terminations and 6" (152mm) on side wall terminations.

**NOTE:** When venting in different pressure zones, the maximum separation requirement of intake and exhaust pipe DOES NOT apply.

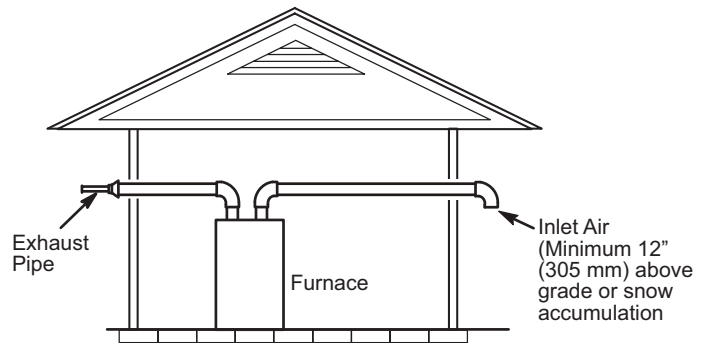
3. On roof terminations, the intake piping should terminate straight down using two 90° elbows (See **Figure 35**).
4. Exhaust piping must terminate straight out or up as shown. A reducer may be required on the exhaust piping at the point where it exits the structure to improve the velocity of exhaust away from the intake piping. See **Table 15**.

**NOTE:** Care must be taken to avoid recirculation of exhaust back into intake pipe.

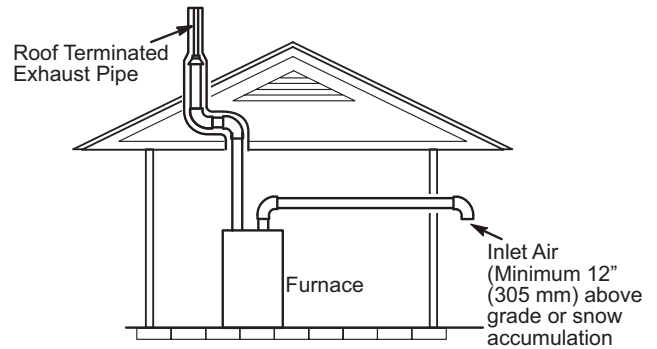
5. On field-supplied terminations for side wall exit, exhaust piping may extend a maximum of 12" (305mm) for 2" PVC and 20" (508mm) for 3" (76mm) PVC beyond the outside wall. Intake piping should be as short as possible. See **Figure 43**.
6. On field-supplied terminations, a minimum distance between the end of the exhaust pipe and the end of the intake pipe without a termination elbow is 8" and a minimum distance of



**Figure 35. Direct Vent Roof Termination Kit Equipment in Confined Space**



**Figure 36. (Inlet Air from Ventilated Crawl Space and Outlet Air to Outside)**



**Figure 37. Exiting Exhaust and Intake Vent (different pressure zone)**

**Table 15. Exhaust Pipe Termination Size Reduction**

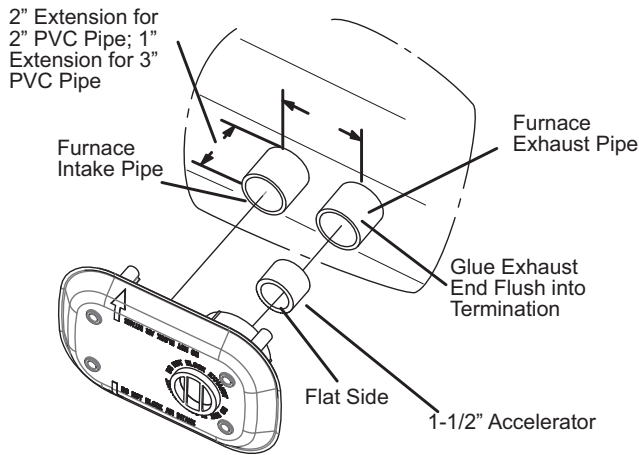
NF96U***S**R Model	Termination Pipe Size
*045, *070	1-1/2" (38mm)
*090	2" (51mm)
110, -135	

\*Use the provided 1-1/2" accelerator if matched with the flush mount termination.

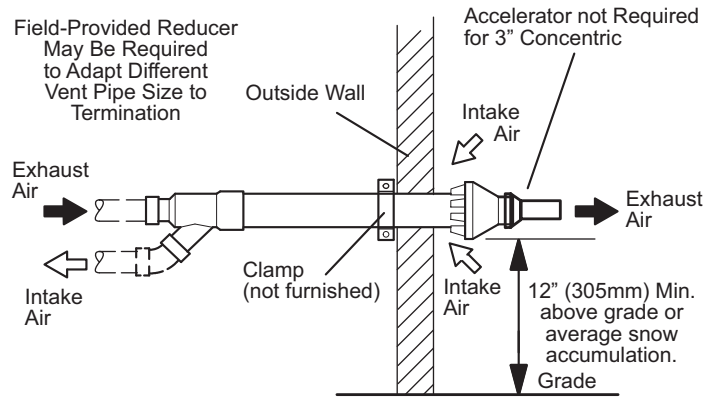
# Service Information

## Details of Intake and Exhaust Piping Terminations for Direct Vent Installations

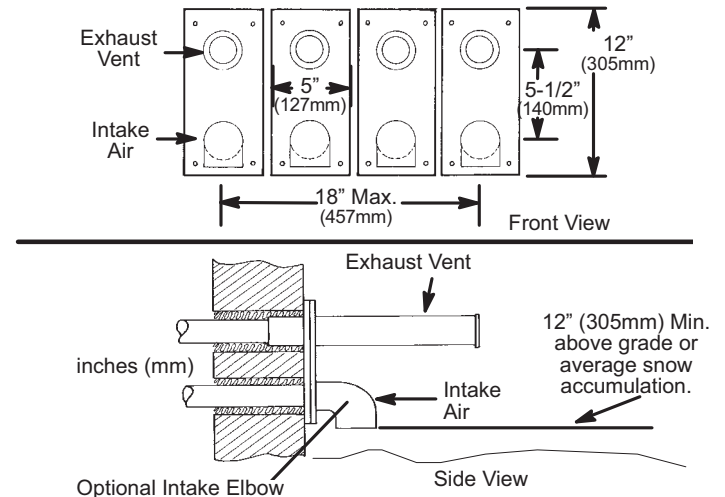
- If intake and exhaust piping must be run up a side wall to position above snow accumulation or other obstructions, piping must be supported. At least one bracket must be used within 6" from the top of the elbow and then every 24" (610mm) as shown in **Figure 43**, to prevent any movement in any direction. When exhaust and intake piping must be run up an outside wall, the exhaust piping must be terminated with pipe sized per **Table 15**. The intake piping may be equipped with a 90° elbow turndown. Using turndown will add 5 feet (1.5m) to the equivalent length of the pipe.
- A multiple furnace installation may use a group of up to four terminations assembled together horizontally, as shown in **Figure 41**.



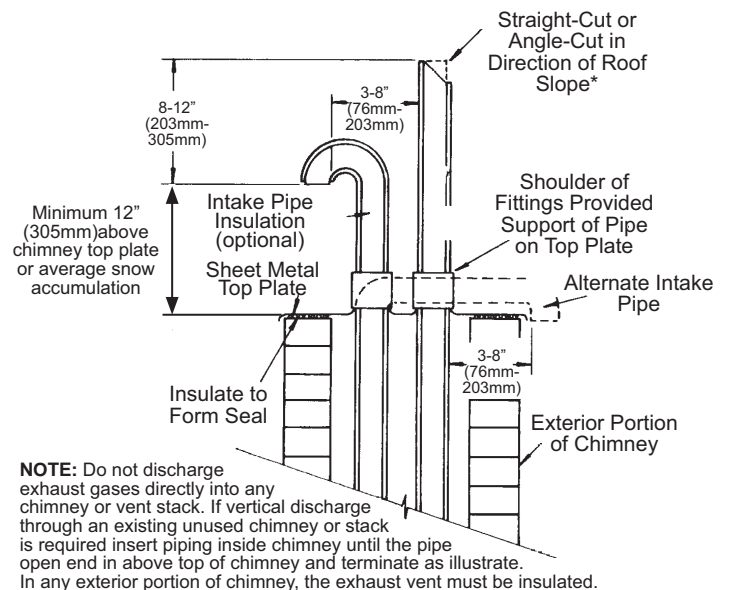
**Figure 38. Flush-Mount Side Wall termination Kit 51W11**



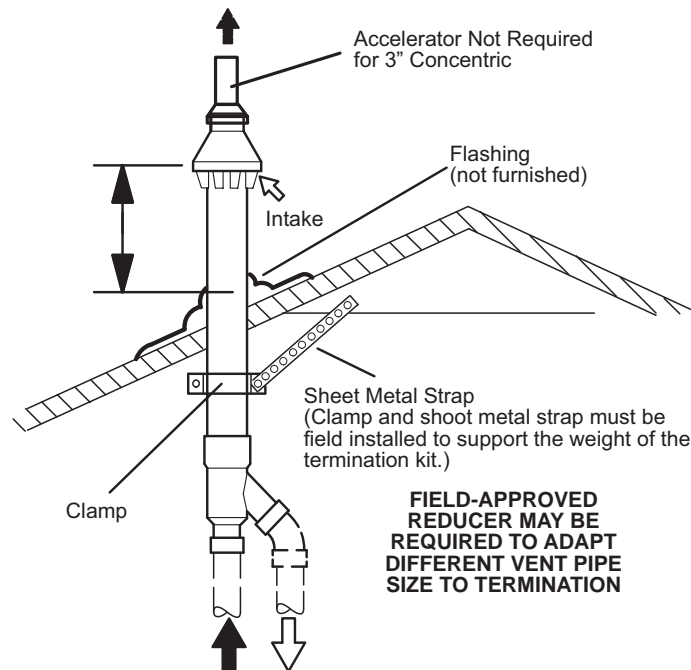
**Figure 40. Direct Vent Concentric Wall Termination 71M80, 69M29 or 60L46)**



**Figure 41. Optional Vent Termination for Multiple Unit Installation of Direct Vent Wall Termination**



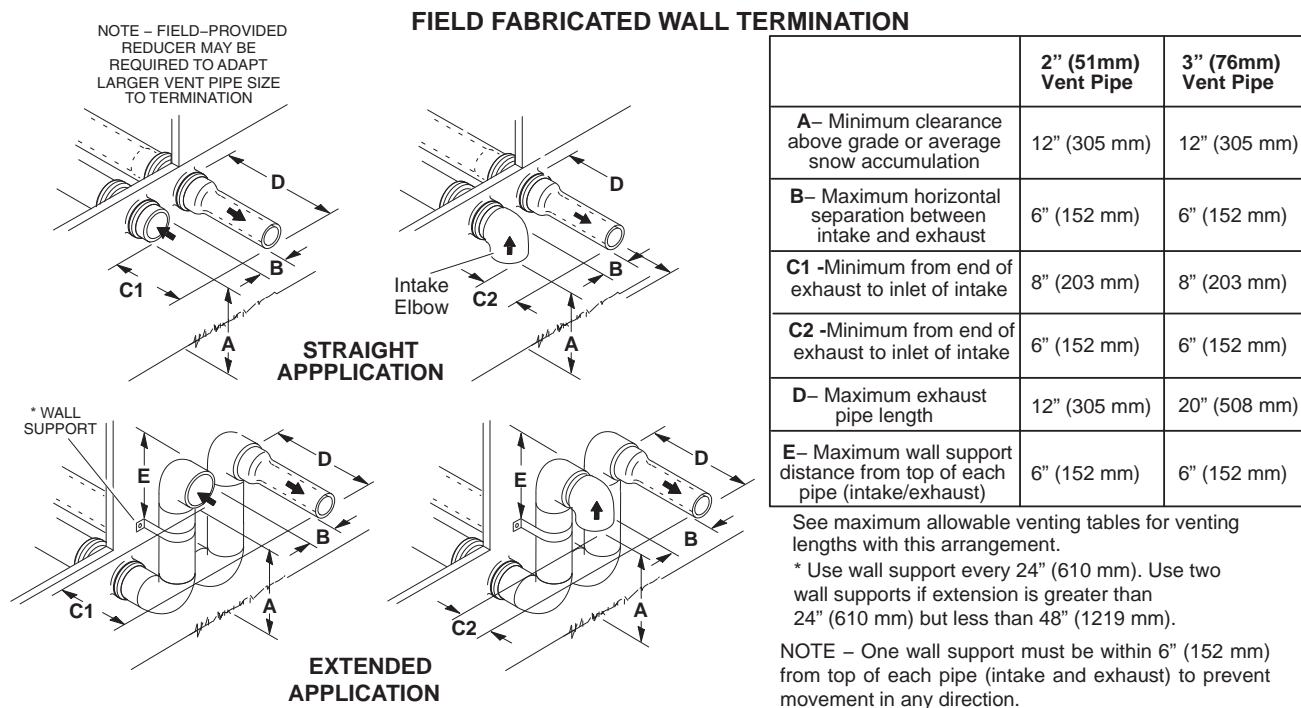
**Figure 42. Direct Vent Application Using Existing Chimney**



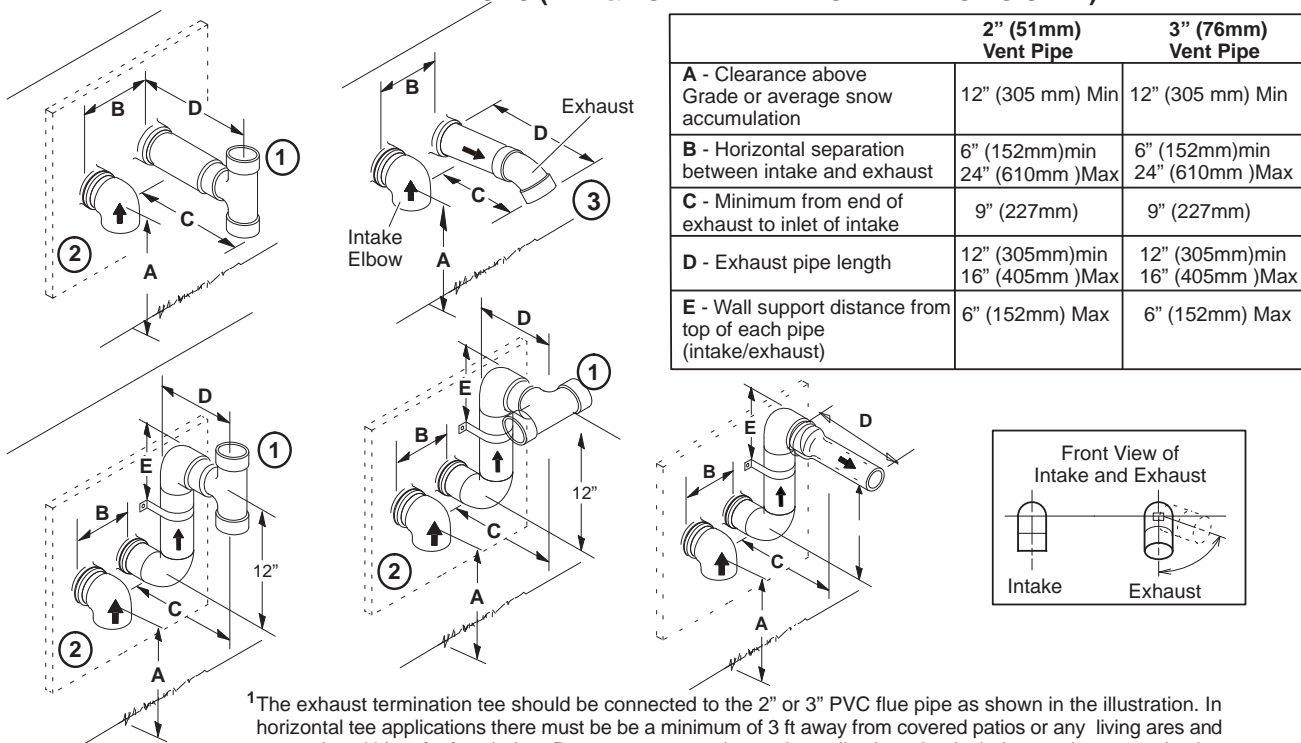
**Figure 39. Direct Vent Concentric Rooftop Termination 71M80, 69M29 or 60L46**

# Service Information

## Details of Intake and Exhaust Piping Terminations for Direct Vent Installations (Cont.)



### ALTERNATE TERMINATIONS (TEE & FORTY-FIVE DEGREE ELBOWS ONLY)



- The exhaust termination tee should be connected to the 2" or 3" PVC flue pipe as shown in the illustration. In horizontal tee applications there must be a minimum of 3 ft away from covered patios or any living areas and cannot be within 3 ft of a window. Do not use an accelerator in applications that include an exhaust termination tee. The accelerator is not required.
- As required. Flue gas may be acidic and may adversely affect some building materials. If a side wall vent termination is used and flue gases will impinge on the building materials, a corrosion-resistant shield (24 inches square) should be used to protect the wall surface. If optional tee is used, the protective shield is recommended. The shield should be constructed using wood, sheet metal or other suitable material. All seams, joints, cracks, etc. in affected area, should be sealed using an appropriate sealant.
- Exhaust pipe 45° elbow can be rotated to the side away from the combustion air inlet to direct exhaust away from adjacent property. The exhaust must never be directed toward the combustion air inlet.

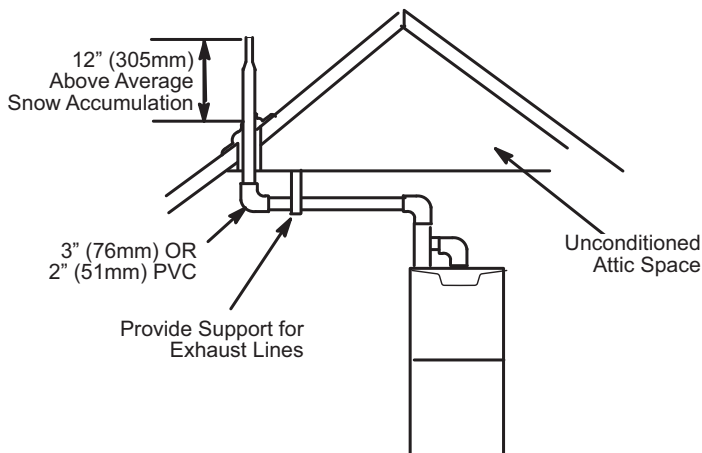
Figure 43.

# Service Information

## Details of Exhaust Piping Terminations for Non-Direct Vent Applications

Exhaust pipes may be routed either horizontally through an outside wall or vertically through the roof. In attic or closet installations, vertical termination through the roof is preferred. **Figure 44** and **Figure 45** shows typical terminations.

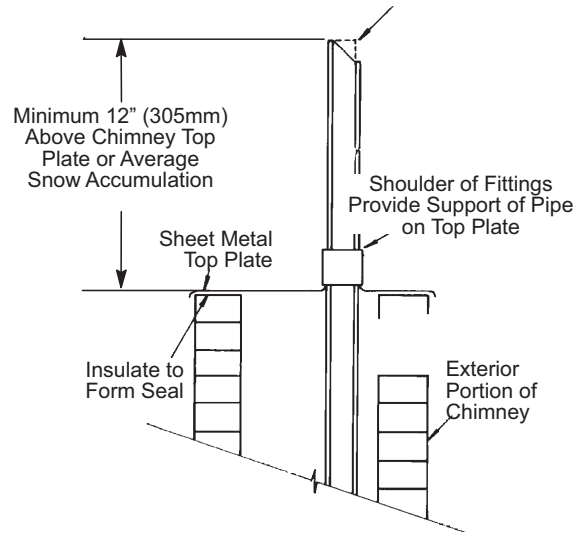
1. Exhaust piping must terminate straight out or up as shown. The termination pipe must be sized as listed in **Table 15**. The specified pipe size ensures proper velocity required to move the exhaust gases away from the building.
2. On field supplied terminations for side wall exit, exhaust piping may extend a maximum of 12" (305mm) for 2" PVC and 20" (508mm) for 3" (76mm) PVC beyond the outside wall.
3. If exhaust piping must be run up a side wall to position above snow accumulation or other obstructions, piping must be supported every 24" (610mm). When exhaust piping must be run up an outside wall, any reduction in exhaust pipe size must be done after the final elbow.
4. Distance between exhaust pipe terminations on multiple furnaces must meet local codes.



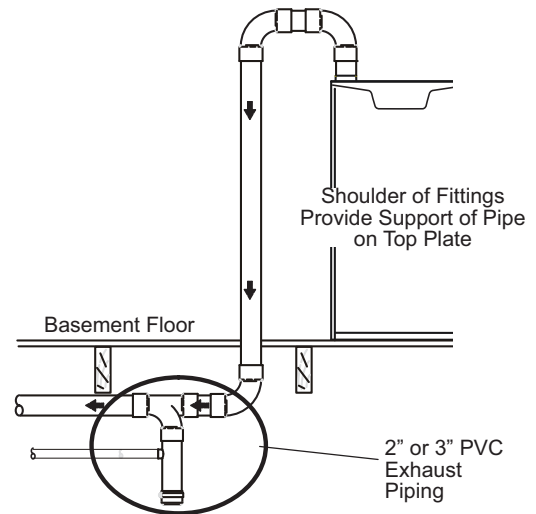
**Figure 44. NON-DIRECT VENT ROOF TERMINATION KIT (15F75 or 44J41)**

## Crawl Space and Extended Horizontal Venting

Install 2" or 3" PVC exhaust piping through the floor joists and into the the crawl space. See **Figure 46**. This can also be used as a supplemental drain for installations with condensate run back in the vent pipe (ie. long horizontal runs, unconditioned spaces, etc.).



**Figure 45. Non-Direct Vent Application Using Existing Chimney**



**Figure 46. Venting in a Crawl Space Basement**

## Condensate Piping

This unit is designed for either right- or left-side exit of condensate piping in upflow applications. In horizontal applications, the condensate trap must extend below the unit. An 8" service clearance is required for the condensate trap. Refer to **Figure 47** and **Figure 48** for condensate trap locations. **Figure 54** shows trap assembly using 1/2" PVC or 3/4" PVC.

**NOTE:** If necessary the condensate trap may be installed up to 5' away from the furnace. Use PVC pipe to connect trap to furnace condensate outlet. Piping from furnace must slope down a minimum of 1/4" per ft. toward trap.

# Service Information

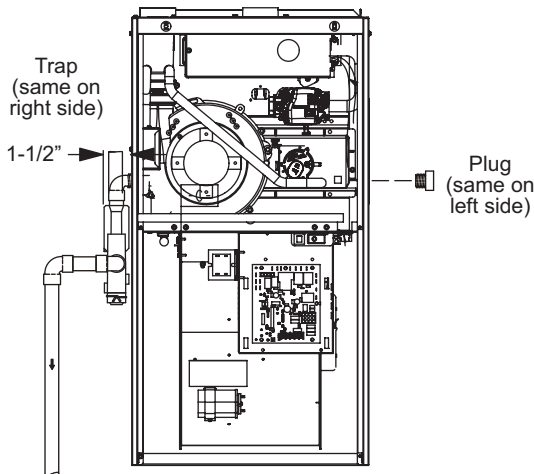
## Condensate Piping (Cont.)

1. Determine which side condensate piping will exit the unit, location of trap, field-provided fittings and length of PVC pipe required to reach available drain.

2. Use a large flat head screw driver or a 1/2" drive socket extension and remove plug (**Figure 47**) from the cold end header box at the appropriate location on the side of the unit. Install provided 3/4 NPT street elbow fitting into cold end header box. Use Teflon tape or appropriate pipe dope.

**NOTE:** Cold end header box drain plugs are factory installed. Check the unused plug for tightness to prevent leakage.

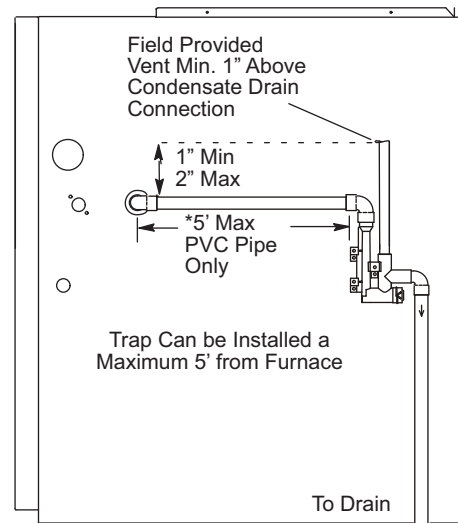
3. Install the cap over the clean out opening at the base of the trap. Secure with clamp. See **Figure 54**.



**NOTE:** In upflow applications where side return air filter is installed on same side as the condensate trap, filter rack must be installed beyond condensate trap or trap must be re-located to avoid interference.

**Figure 47. Condensate Trap and Plug Locations (Unit shown in upflow position)**

4. Install drain trap using appropriate PVC fittings, glue all joints. Glue the provided drain trap as shown in **Figure 55**. Route the condensate line to an open drain. Condensate line must maintain a 1/4" downward slope from the furnace to the drain.



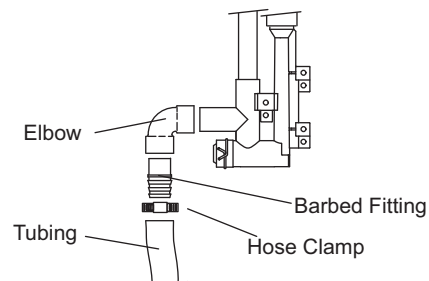
\*Piping from furnace must slope down a minimum 1/4" per ft. toward trap

**Figure 48. Condensate Trap Locations (Unit shown in upflow position with remote trap)**

5. **Figure 51** and **Figure 53** shows the furnace and evaporator coil using a separate drain. If necessary the condensate line from the furnace and evaporator coil can drain together. See **Figure 52** and **Figure 54**. Upflow furnace (**Figure 52**) - In upflow furnace applications the field provided vent must be a minimum 1" to a maximum 2" length above the condensate drain outlet connection. Any length above 2" may result in a flooded heat exchanger if the combined primary drain line were to become restricted. Horizontal furnace (**Figure 54**) - In horizontal furnace applications the field provided vent must be a minimum 4" to a maximum 5" length above the condensate drain outlet connection. Any length above 5" may result in a flooded heat exchanger if the combined primary drain line were to become restricted.

**NOTE:** In horizontal applications it is recommended to install a secondary drain pan underneath the unit and trap assembly.

**NOTE:** Appropriately sized tubing and barbed fitting may be used for condensate drain. Attach to the drain on the trap using a hose clamp. See **Figure 49**.



**Figure 49. Field Provided Drain Components**

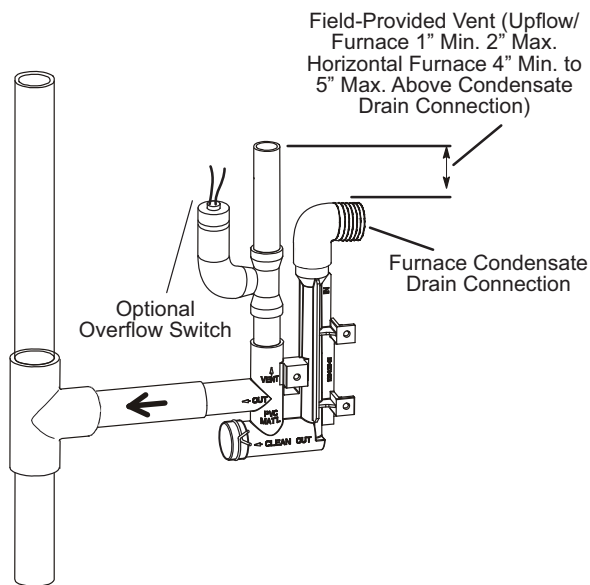
# Service Information

## Condensate Piping (Cont.)

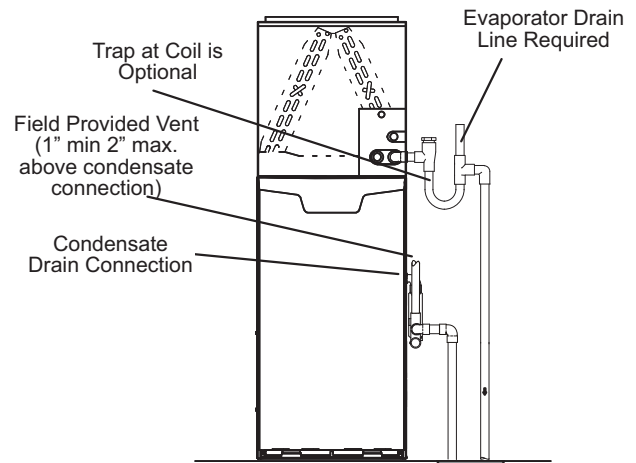
**CAUTION** Do not use copper tubing or existing copper condensate lines for drain line.

6. If unit will be started immediately upon completion of installation, prime trap per procedure outlined in Unit Start-Up section.

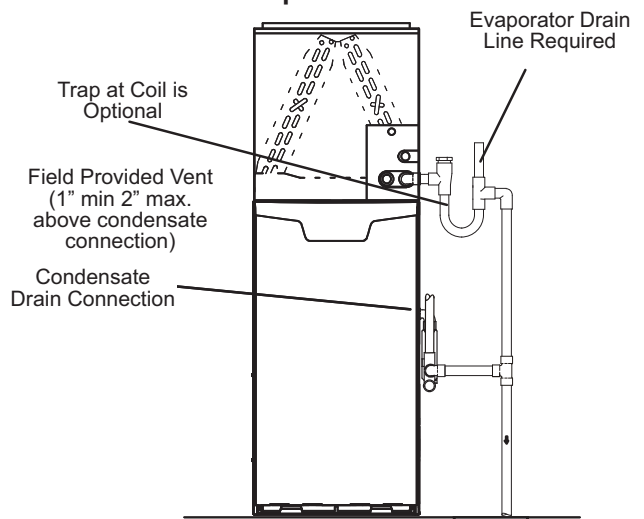
Condensate line must slope downward away from the trap to drain. If drain level is above condensate trap, condensate pump must be used. Condensate drain line should be routed within the conditioned space to avoid freezing of condensate and blockage of drain line. If this is not possible, a heat cable kit may be used on the condensate trap and line.



**Figure 50. Condensate Trap with Optional Overflow Switch**



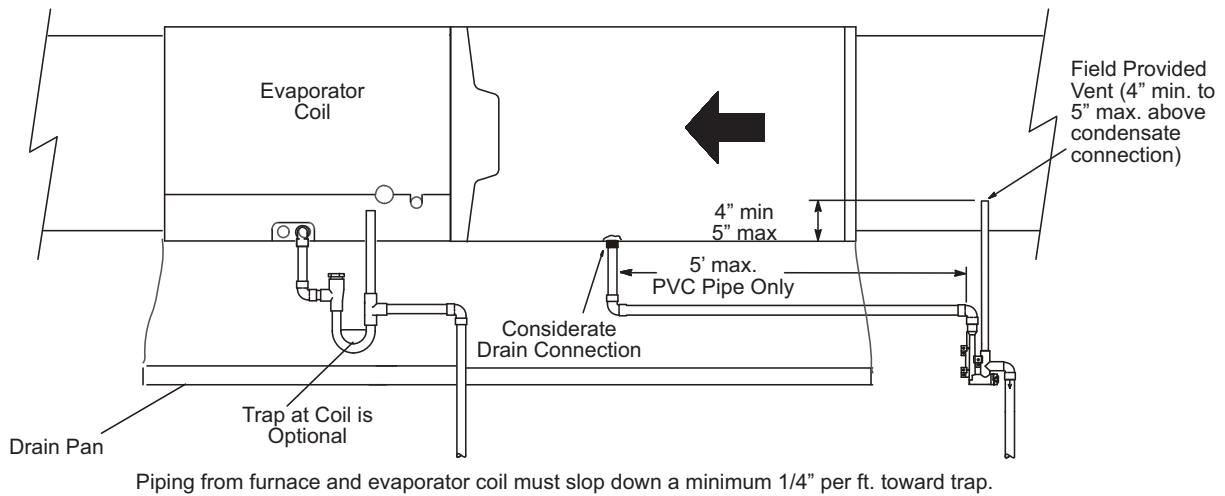
**Figure 51. Furnace with Evaporator Coil Using a Separate Drain**



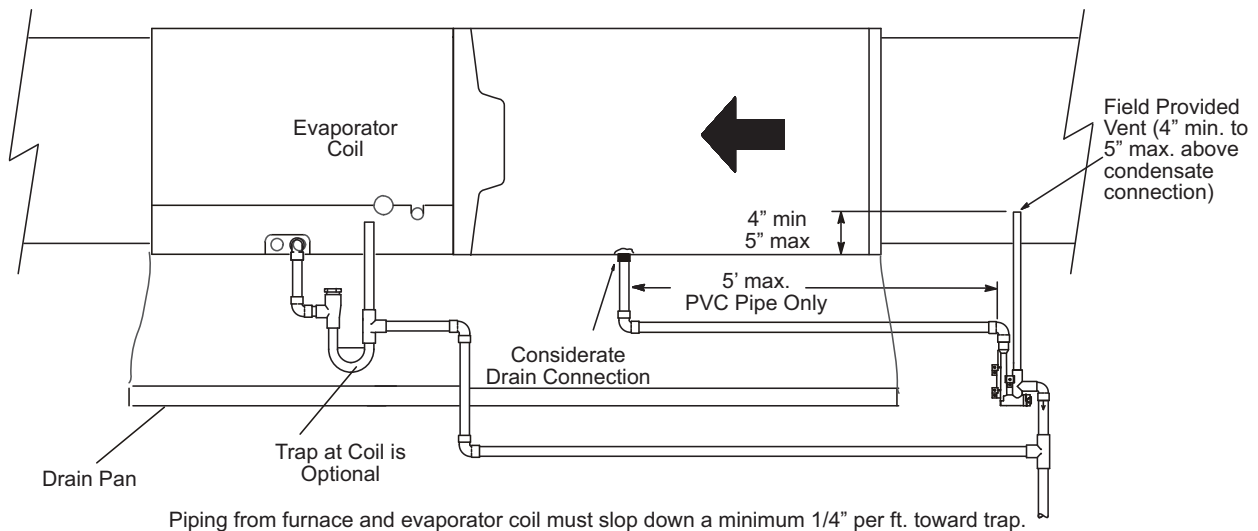
**Figure 52. Furnace with Evaporator Coil Using a Common Drain**

# Service Information

## Condensate Piping (Cont.)



**Figure 53. Furnace with Evaporator Coil Using a Separate Drain  
(Unit shown in horizontal left-hand discharge position)**



**Figure 54. Furnace with Evaporator Coil Using a Common Drain  
(Unit shown in horizontal left-hand discharge position)**

### **▲ IMPORTANT**

When combining the furnace and evaporator coil drains together, the A/C condensate drain outlet must be vented to relieve pressure in order for the furnace pressure switch to operate properly.

# Service Information

## Condensate Piping (Cont.)

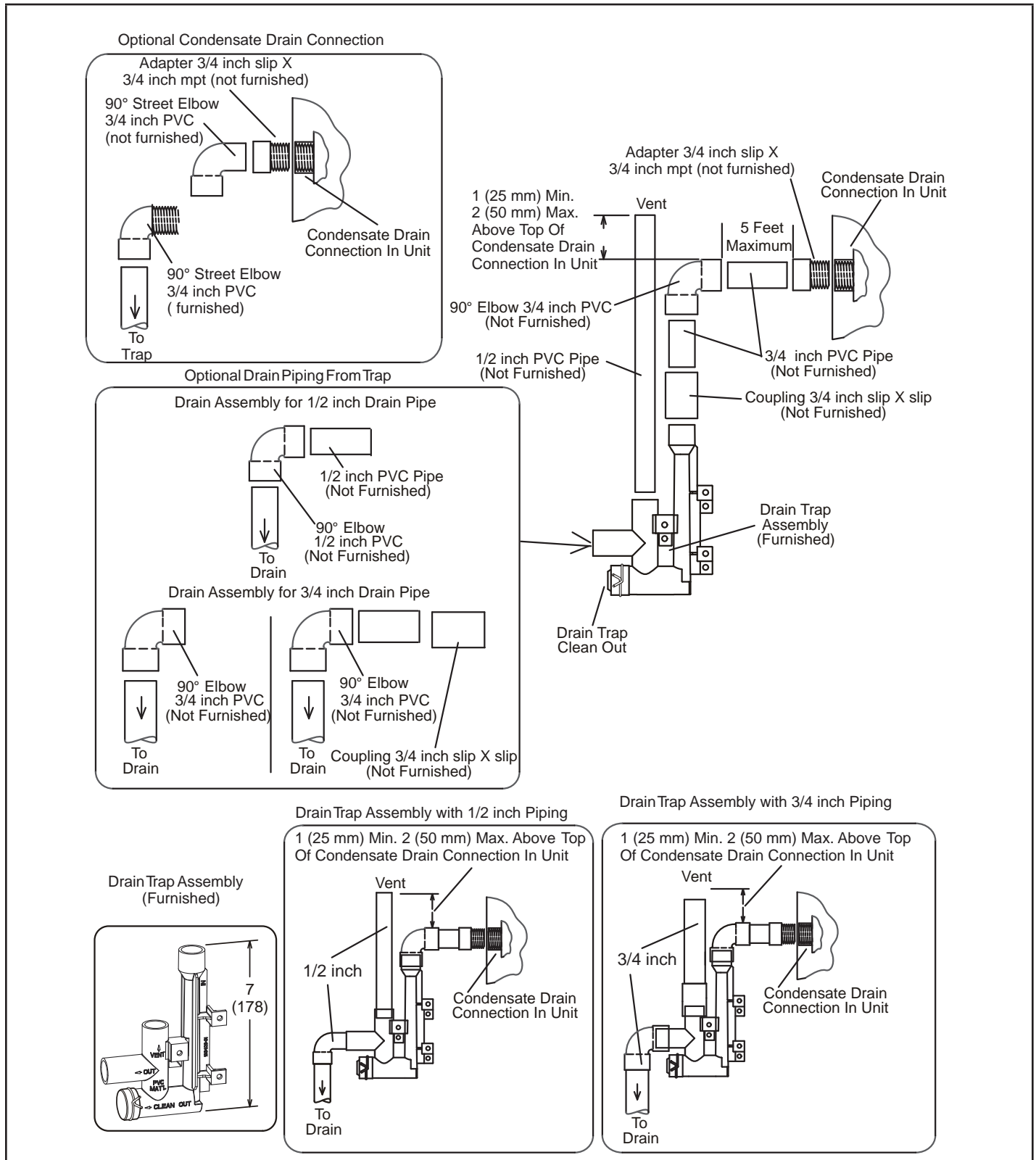


Figure 55. Trap/Drain Assembly Above Using 1/2" PVC or 3/4" PVC

# Service Information

## START-UP

### Preliminary and Seasonal Checks

1. Inspect electrical wiring, both field and factory installed for loose connections. Tighten as required.
2. Check voltage at disconnect switch. Voltage must be within range listed on the nameplate. If not, consult the power company and have voltage condition corrected before starting unit.
3. Inspect condition of condensate traps and drain assembly.

Disassemble and clean seasonally.

### Heating Start-Up

**BEFORE LIGHTING** the unit, smell all around the furnace area for gas. Be sure to smell next to the floor because some gas is heavier than air and will settle on the floor.

The gas valve on the NF96U\*\*\*S\*\*R is equipped with a gas control switch. Use only your hand to move the switch.

Never use tools. If the the switch will not move by hand, replace the valve. Do not try to repair it. Force or attempted repair may result in a fire or explosion.

### Placing the furnace into operation:

NF96U\*\*\*S\*\*R units are equipped with a ignition system. Do not attempt to manually light burners on this furnace. Each time the thermostat calls for heat, the burners will automatically light. The ignitor does not get hot when there is no call for heat on units with ignition system.

### Priming Condensate Trap

The condensate trap should be primed with water prior to start-up to ensure proper condensate drainage. Either pour 10 fl. oz. (300 ml) of water into the trap, or follow these steps to prime the trap:

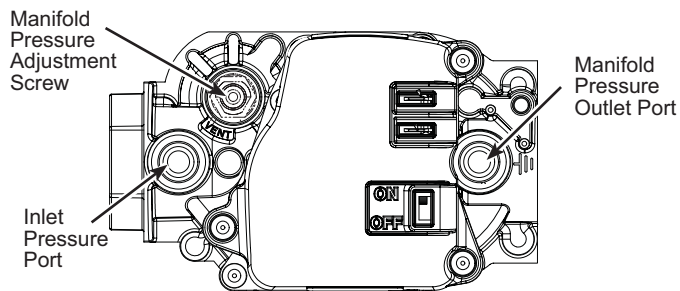
1. Follow the lighting instructions to place the unit into operation.
2. Set the thermostat to initiate a heating demand.
3. Allow the burners to fire for approximately 3 minutes.
4. Adjust the thermostat to deactivate the heating demand.
5. Wait for the combustion air inducer to stop. Set the thermostat to initiate a heating demand and again allow the burners to fire for approximately 3 minutes.
6. Adjust the thermostat to deactivate the heating demand and again wait for the combustion air inducer to stop. At this point, the trap should be primed with sufficient water to ensure proper condensate drain operation.

**⚠ WARNING** If you do not follow these instructions exactly, a fire or explosion may result causing property damage, personal injury or death.

### Gas Valve Operation (Figure 56)

1. STOP! Read the safety information at the beginning of this section.
2. Set the thermostat to the lowest setting.

3. Turn off all electrical power to the unit.
4. This furnace is equipped with an ignition device which automatically lights the burners. Do not try to light the burners by hand.
5. Remove the outer access panel.
6. Move gas valve switch to OFF. See **Figure 56**.
7. Wait five minutes to clear out any gas. If you then smell gas, **STOP!** Immediately call your gas supplier from a neighbor's phone. Follow the gas supplier's instructions. If you do not smell gas go to next step.
8. Move gas valve switch to ON. See **Figure 56**.



**Figure 56. Gas Valve Shown in ON Position**

9. Replace the upper outer access panel.
10. Turn on all electrical power to to the unit.
11. Set the thermostat to desired setting.  
**NOTE:** When unit is initially started, steps 1 through 11 may need to be repeated to purge air from gas line.
12. If the appliance will not operate, follow the instructions "Turning Off Gas to Unit" and call your service technician or gas supplier.

### Turning Off Gas to Unit

1. Set the thermostat to the lowest setting.
2. Turn off all electrical power to the unit if service is to be performed.
3. Remove the outer access panel.
4. Move gas valve switch to OFF.
5. Replace the outer access panel.

### Failure To Operate

If the unit fails to operate, check the following:

1. Is the thermostat calling for heat?
2. Are access panels securely in place?
3. Is the main disconnect switch closed?
4. Is there a blown fuse or tripped breaker?
5. Is the filter dirty or plugged? Dirty or plugged filters will cause the limit control to shut the unit off.
6. Is gas turned on at the meter?
7. Is the manual main shut-off valve open?
8. Is the internal manual shut-off valve open?
9. Is the unit ignition system in lockout? If the unit locks out again, inspect the unit for blockages.

# Service Information

## HEATING SYSTEM SERVICE CHECKS

### C.S.A. Certification

All units are C.S.A. design certified without modifications. Refer to the NF96U\*\*\*S\*\*R Operation and Installation Instruction Manual Information.

### Gas Piping

**▲ IMPORTANT** If a flexible gas connector is required or allowed by the authority that has jurisdiction, black iron pipe shall be installed at the gas valve and extend outside the furnace cabinet. The flexible connector can then be added between the black iron pipe and the gas supply line.

**▲ WARNING** Do not over torque (800 in-lbs) or under torque (350 in-lbs) when attaching the gas piping to the gas valve.

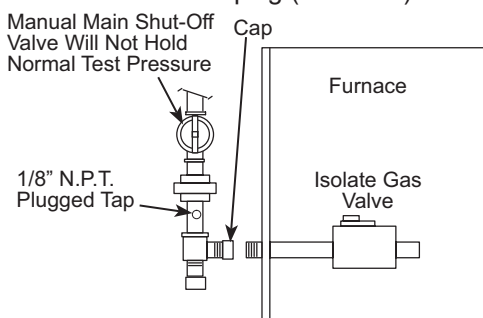
Gas supply piping should not allow more than 0.5" W.C. drop in pressure between gas meter and unit. Supply gas pipe must not be smaller than unit gas connection.

Compounds used on gas piping threaded joints should be resistant to action of liquefied petroleum gases.

### Testing Gas Piping

**▲ IMPORTANT** In case emergency shutdown is required, turn off the main shut-off valve and disconnect the main power to unit. These controls should be properly labeled by the installer.

When pressure testing gas lines, the gas valve must be disconnected and isolated. Gas valves can be damaged if subjected to more than 0.5 psig (14" W.C.). See **Figure 57**.



**Figure 57.**

When checking piping connections for gas leaks, use preferred means. Kitchen detergents can cause harmful corrosion on various metals used in gas piping. Use of a specialty Gas Leak Detector is strongly recommended. It is available through GE Appliances under part number 31B2001.

**▲ WARNING** Do not use matches, candles, flame or any other source of ignition to check for gas leaks.

## Gas Supply Pressure

### Gas Flow (Approximate)

**Table 16.**

GAS METER CLOCKING CHART				
Unit	Seconds for One Revolution			
	Natural		LP/Propane	
	1 cu ft Dial	2 cu ft Dial	1 cu ft Dial	2 cu ft Dial
-045	80	160	200	400
-070	55	110	136	272
-090	41	82	102	204
-110	33	66	82	164
-135	27	54	68	136
Natural-1000 btu/cu ft			LP-2500 btu/cu ft	

Furnace should operate at least 5 minutes before checking gas flow. Determine time in seconds for two revolutions of gas through the meter. (Two revolutions assures a more accurate time.) Divide by two and compare to time in **Table 16**. If manifold pressure matches **Table 18** and rate is incorrect, check gas orifices for proper size and restriction. Remove temporary gas meter if installed.

**NOTE:** To obtain accurate reading, shut off all other gas appliances connected to meter.

### Supply Pressure Measurement

When testing supply gas pressure, use the 1/8" N.P.T. plugged tap located on the gas valve to facilitate test gauge connection. See **Figure 56**. Check gas line pressure with unit firing at maximum rate. Low pressure may result in erratic operation or underfire. High pressure can result in permanent damage to gas valve or overfire.

On multiple unit installations, each unit should be checked separately, with and without other units operating. Supply pressure must fall within range listed in **Table 18**.

### Manifold Pressure Measurement

Follow the steps below and use **Figure 58** as a reference.

1. Connect the test gauge positive side "+" to manifold pressure tap on gas valve.
2. Tee into the gas valve regulator vent hose and connect to test gauge negative "-".
3. Start unit and let run for 5 minutes to allow for steady state conditions.
4. After allowing unit to stabilize for 5 minutes, record manifold pressure and compare to value given in **Table 18**.
5. Shut unit off and remove manometer as soon as an accurate reading has been obtained. Take care to remove barbed fitting and replace threaded plug.
6. Start unit and perform leak check. Seal leaks if found.

# Service Information

## Testing Gas Supply Pressure (Cont.)

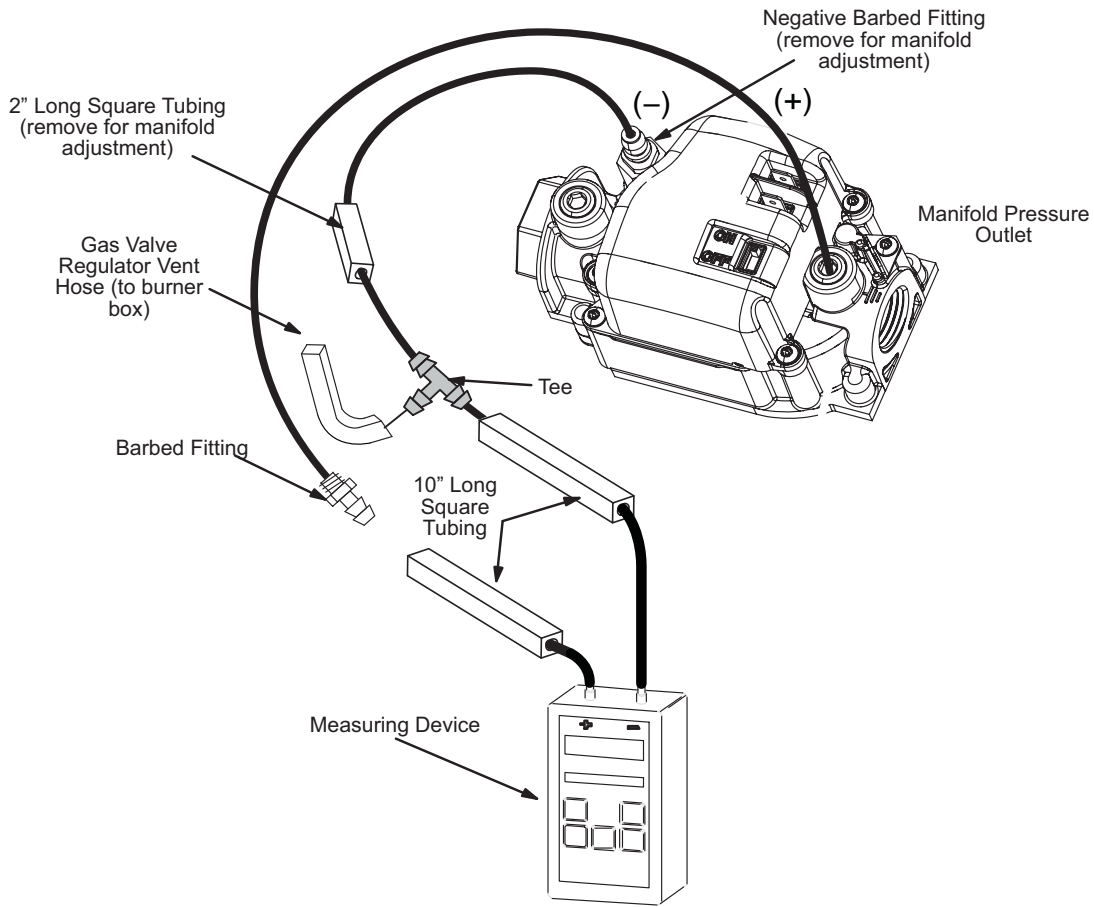


Figure 58.

### Proper Combustion

Furnace should operate at least 15 minutes with correct manifold pressure and gas flow rate before checking combustions. Take sample beyond the flue outlet and compare to **Table 17**. **The maximum carbon monoxide reading should not exceed 100 ppm.**

Table 17.

Unit	CO2% Nat	CO2% LP
-045	7.5- 8.5	8.2 - 9.5
-070		
-090		
-110		
-135		

### High Altitude

**NOTE:** In Canada, certification for installations at elevations over 4500 feet (1372 m) is the jurisdiction of local authorities.

Some units installed at altitude of 4501 - 10,000 feet (1373 to 3048 m) may require a pressure switch change which can be ordered separately and a manifold de-rate. See **Table 18** for manifold pressures at all altitudes. **Table 19** lists conversion kit and pressure switch requirements at varying altitudes.

The combustion air pressure switch is factory-set and requires no adjustment.

# Service Information

## High Altitude (Cont.)

**Table 18. Manifold and Supply Line Pressure 0-10,000ft.**

Unit	Gas	Manifold Pressure in. wg.					Supply Line Pressure in. w.g. 0 - 10000 ft.	
		0 - 4500 ft	4501 - 5500 ft	5501 - 6500 ft	6501 - 7500 ft	7501 - 10,000 ft		
All Models	Natural	3.5	3.3	3.2	3.1	3.5	4.5	13.0
	L.P. Propane	10.0	9.4	9.1	8.9	10.0	11.0	13.0

**NOTE:** A natural to L.P. propane gas changeover kit is necessary to convert this unit. Refer to the changeover kit installation instruction for the conversion procedure.


**Table 19. Conversion Kit and Pressure Switch Requirements at Varying Altitudes**

Unit	Natural to LP/ Propane	High Altitude Natural Burner Orifice Kit	High Altitude LP/ Propane Burner Orifice Kit	High Altitude Pressure Switch	
				4501 - 7500 ft (1373 - 2286m)	7501 -10,000 ft (2286 - 3048m)
	0 - 7500 ft (0 - 2286m)	7501 - 10,000 ft (2286 - 3038m)	7501 - 10,000 ft (2286 - 3038m)		
-045	11K49	73W37	11K44	11U66	11U69
-070				11U70	11U68
-090				11U70	11U64
-110				11U70	11U64
-135				11U70	11U68

Pressure switch is factory set. No adjustment necessary. All models use the factory-installed pressure switch from 0-4500 feet (0-1370 m).

# Service Information

## Proper Ground and Voltage (Cont.)

**⚠ WARNING**  **Electric Shock Hazard. Can cause injury or death. Unit must be properly grounded in accordance with national and local codes.**

A poorly grounded furnace can contribute to premature ignitor failure. Use the following procedure to check for ground and voltage to the integrated control.

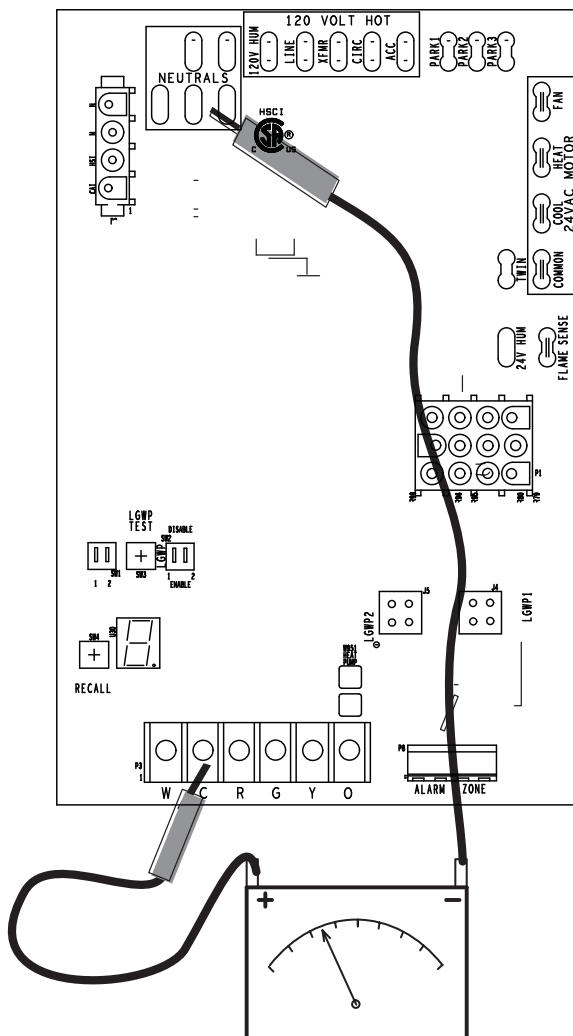
1. Measure the AC voltage between Line Neutral (spade terminals) and "C" terminal (low voltage terminal block) on the integrated control. See **Figure 59**. A wide variation in the voltage between Line Neutral and "C" as a function of load indicates a poor or partial ground. Compare the readings to the table below. If the readings exceed the maximum shown in **Table 20**, make repairs before operating the furnace.

2. In addition, measure the AC voltage from Line Hot to Line Neutral (spade terminals) on the integrated control. See **Figure 59**. This voltage should be in the range of 97 to 132 Vac.

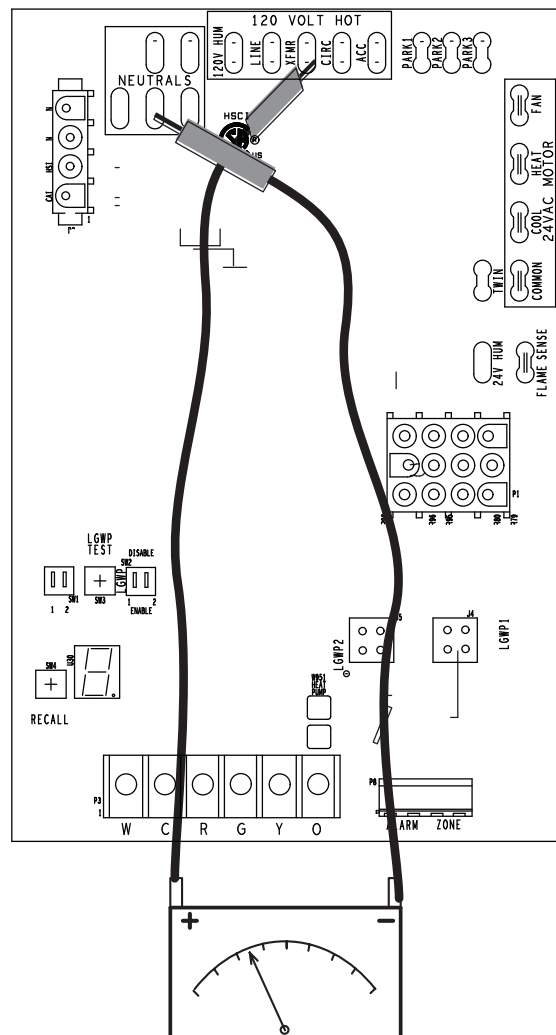
**Table 20.**

Furnace Status	Measurement VAC	
	Expected	Maximum
Power On Furnace Idle	0.3	2
CAI / Ignitor Energized	0.75	5
Indoor Blower Energized	Less than 2	10

### Check Voltage Between Line Neutral And Low Voltage "C" Terminal



### Check Voltage Between Line Hot And Line Neutral



**Figure 59.**

# Service Information

## TYPICAL OPERATING CHARACTERISTICS

### Blower Operation and Adjustment<sup>1</sup>

**NOTE:** The following is a generalized procedure and does not apply to all thermostat controls.

1. Blower operation is dependent on thermostat control system
2. Generally, blower operation is set at thermostat subbase fan switch. With fan switch in ON position, blower operates continuously. With fan switch in AUTO position, blower cycles with demand or runs continuously while heating or cooling circuit cycles.
3. Depending on the type of indoor thermostat, blower and entire unit will be off when the system switch is in OFF position.

### Temperature Rise (Figure 60)

Temperature rise for NF96U\*\*\*S\*\*R units depends on unit input, blower speed, blower horsepower and static pressure as marked on the unit rating plate. The blower speed must be set for unit operation within the range of "TEMP. RISE °F" listed on the unit rating plate.

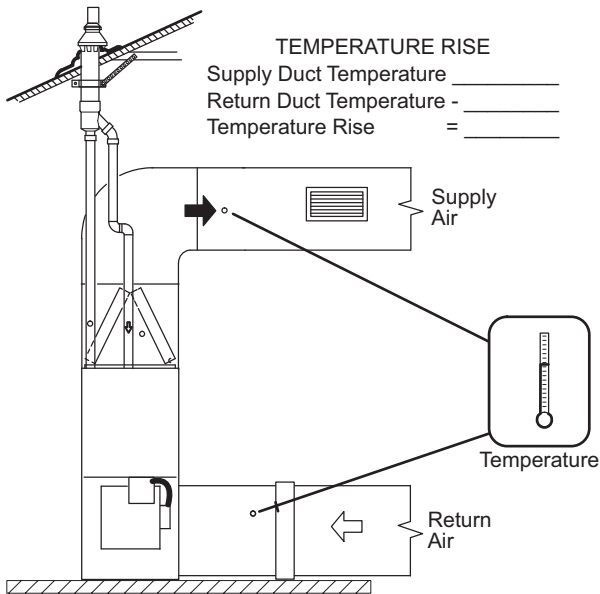


Figure 60.

### External Static Pressure

1. Tap locations shown in **Figure 61**.
2. Punch a 1/4" diameter hole in supply and return air plenums. Insert manometer hose flush with inside edge of hole or insulation. Seal around the hose with permagum. Connect the zero end of the manometer to the discharge (supply) side of the system. On ducted systems, connect the other end of manometer to the return duct as above.
3. With only the blower motor running and the evaporator coil dry, observe the manometer reading. Adjust blower motor speed to deliver the air desired according to the job requirements. For heating speed external static pressure drop must not be more than 0.5" W.C. For cooling speed external static pressure drop must not be more than 0.8" W.C.
4. Seal the hole when the check is complete.

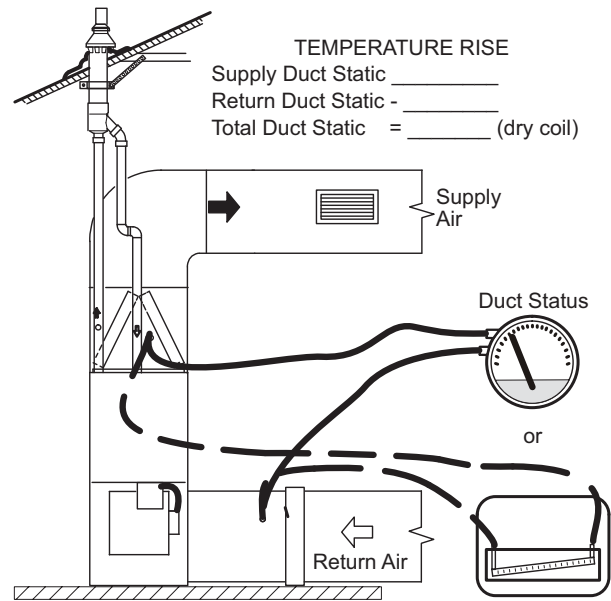


Figure 61.

### Blower Speed Taps

Blower speed tap changes are made on the integrated control. The heating tap is connected to the "HEAT" terminal and the cooling tap is connected to the "COOL" terminal. On all units the continuous blower tap is connected to the "FAN" terminal. Unused taps must be secured on two dummy terminals labeled "PARK". To change out existing speed tap, turn off power and switch out speed tap with tap connected to "PARK". See blower speed tap table on unit diagram for motor tap colors for each speed.

# Service Information

## MAINTENANCE

**⚠ WARNING ELECTRICAL SHOCK, FIRE, OR EXPLOSION HAZARD.** Failure to follow safety warnings exactly could result in dangerous operation, serious injury, death or property damage. Improper servicing could result in dangerous operation, serious injury, death, or property damage. Before servicing, disconnect all electrical power to the furnace.

At the beginning of each heating season, system should be checked as follows by a qualified service technician:

### Blower

Check the blower wheel for debris and clean if necessary. The blower motors are prelubricated for extended bearing life. No further lubrication is needed.

**⚠ WARNING** The blower access panel must be securely in place when the blower and burners are operating. Gas fumes, which could contain carbon monoxide, can be drawn into living space resulting in personal injury or death.

### Filters

All air filters are installed external to the unit. Filters should be inspected monthly. Clean or replace the filters when necessary to ensure proper furnace operation. **Table 21** lists recommended filter

**⚠ WARNING** If a high efficiency filter is being installed as part of this system to ensure better indoor air quality, the filter must be properly sized. High efficiency filters have a higher static pressure drop than standard efficiency glass/foam filters.

If the pressure drop is too great, system capacity and performance may be reduced. The pressure drop may also cause the limit to trip more frequently during the winter and the indoor coil to freeze in the summer, resulting in an increase in the number of service calls.

Before using any filter with this system, check the specifications provided by the filter manufacturer against the data given in the appropriate GE Appliances Product Specifications bulletin.

Furnace Cabinet Width	Filter Size	
	Side Return	Bottom Return
17-1/2"	16 X 25 X 1 (1)	16 X 25 X 1 (1)
21"	16 X 25 X 1 (1)	20 X 25 X 1 (1)
24-1/2"	16 X 25 X 1 (2)	24 X 25 X 1 (1)

**Table 21.**

Check the exhaust and air intake pipes and all connections for tightness and to make sure there is no blockage.

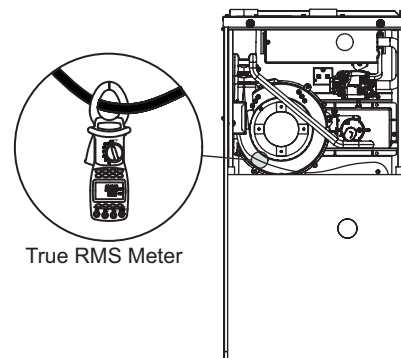
**NOTE:** After any heavy snow, ice or frozen fog event the furnace vent pipes may become restricted. Always check the vent system and remove any snow or ice that may be obstructing the plastic intake or exhaust pipes.

### Electrical

**⚠ WARNING Fire Hazard.** Use of aluminum wire with this product may result in a fire, causing property damage, severe injury or death. Use copper wire only with this product.

**⚠ WARNING** Failure to use properly sized wiring and circuit breaker may result in property damage. Size wiring and circuit breaker(s) per Product Specifications bulletin (EHB) and unit rating plate.

1. Check all wiring for loose connections.
2. Check for the correct voltage at the furnace (furnace operating). Correct voltage is 120VAC + 10%
3. Check amp-draw using a true RMS meter on the blower motor with blower access panel in place. See **Figure 62**.  
Furnace Nameplate \_\_\_\_\_ Actual \_\_\_\_\_
4. Inspect the Low GWP sensor / sensors and rubber sleeve.



**Figure 62. Check Motor AMP Draw (Typical set-up with upflow furnace shown)**

# Service Information

## Winterizing and Condensate Trap Care

1. Turn off power to the furnace.
2. Have a shallow pan ready to empty condensate water.
3. Remove the clean out cap from the condensate trap and empty water. Inspect the trap then reinstall the clean out cap.

## Condensate Hose Screens (Figure 63)

Check the condensate hose screens for blockage and clean if necessary.

1. Turn off power to the unit.
2. Remove hoses from cold end header box. Twist and pull screens to remove.
3. Inspect screens and rinse with tap water if needed.
4. Reinstall screens, reconnect hoses and turn on power to unit.

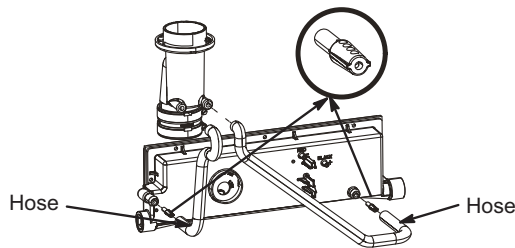


Figure 63. Condensate Hose Screens

## Cleaning Heat Exchanger

If cleaning the heat exchanger becomes necessary, follow the below procedures and refer to figure 1 when disassembling unit. Use papers or protective covering in front of furnace while removing heat exchanger assembly.

1. Turn off electrical and gas supplies to the furnace.
2. Remove the furnace access panels.
3. Disconnect the 2 wires from the gas valve.
4. Remove gas supply line connected to gas valve. Remove the burner box cover (if equipped) and remove gas valve/manifold assembly.
5. Remove sensor wire from sensor. Disconnect 2-pin plug from the ignitor.
6. Disconnect wires from flame roll-out switches.
7. Disconnect combustion air intake pipe. It may be necessary to cut the existing pipe to remove burner box assembly.
8. Remove four burner box screws at the vestibule panel and remove burner box. Set burner box assembly aside.  
**NOTE:** If necessary, clean burners at this time. Follow procedures outlined in Burner Cleaning section.
9. Loosen the clamps to the flexible exhaust coupling.
10. Disconnect condensate drain line from the cold end header box.
11. Disconnect condensate drain tubing from flue collar. Remove screws that secures the flue collar into place. Remove flue collar. It may be necessary to cut the exiting exhaust pipe for removal of the fitting.

12. Mark and disconnect all combustion air pressure tubing from cold end header collector box.
13. Mark and remove wires from pressure switch assembly. Remove the assembly. Keep tubing attached to pressure switches.
14. Disconnect the plug from the combustion air inducer. Remove two screws which secure combustion air inducer to collector box. Remove combustion air inducer assembly. Remove ground wire from vest panel.
15. Disconnect the condensate drain line.
16. Remove cold end header box.
17. Remove electrical junction box from the side of the furnace.
18. Mark and disconnect any remaining wiring to heating compartment components. Disengage strain relief bushing and pull wiring and bushing through the hole in the blower deck.
19. Remove the primary limit from the vestibule panel.
20. Remove two screws from the front cabinet flange at the blower deck. Spread cabinet sides slightly to allow clearance for removal of heat exchanger.
21. Remove screws along vestibule sides and bottom which secure vestibule panel and heat exchanger assembly to cabinet. Remove two screws from blower rail which secure bottom heat exchanger flange. Remove heat exchanger from furnace cabinet.
22. Back wash heat exchanger with soapy water solution or steam. If steam is used it must be below 275°F (135°C).
23. Thoroughly rinse and drain the heat exchanger. Soap solutions can be corrosive. Take care to rinse entire assembly.
24. Reinstall heat exchanger into cabinet making sure that the clamshells of the heat exchanger assembly is engaged properly into the support bracket on the blower deck. Remove the indoor blower to view this area through the blower opening.
25. Re-secure the supporting screws along the vestibule sides and bottom to the cabinet.
26. Reinstall cabinet screws on front flange at blower deck.
27. Reinstall the primary limit on the vestibule panel.
- 28/ Route heating component wiring through hole in blower deck and reinsert strain relief bushing.
29. Reinstall electrical junction box.
30. Reinstall the cold end header box.
31. Reinstall the combustion air inducer. Reconnect the plug to the wire harness.
32. Reinstall pressure switches and reconnect pressure switch wiring.
33. Carefully connect combustion air pressure switch tubing from pressure switches to proper ports on cold end header collector box.
34. Reconnect condensate drain line to the cold end header box.

# Service Information

---

## Cleaning Heat Exchanger (Cont.)

35. Use securing screws to reinstall flue collar to the top cap on the furnace. Reconnect exhaust piping and exhaust drain tubing.
36. Replace flexible exhaust adapter on combustion air inducer and flue collar. Secure using two existing hose clamps.
37. Reinstall burner box assembly in vestibule area. Secure burner box assembly to vestibule panel using four existing screws. Make sure burners line up in center of burner ports.
38. Reconnect flame roll-out switch wires.
39. Reconnect sensor wire and reconnect 2-pin plug from ignitor.
40. Reinstall gas valve manifold assembly. Reconnect gas supply line to gas valve.
41. Reconnect the combustion air intake pipe.
42. Reinstall burner box cover.
43. Reconnect wires to gas valve.
44. Replace the blower compartment access panel.
45. Reconnect gas supply piping. Turn on power and gas supply to unit.
46. Follow lighting instructions on unit nameplate to light and operate furnace for 5 minutes to ensure the furnace is operating properly.
47. Check all piping connections, factory and field, for gas leaks. Use a leak detecting solution or other preferred means.
48. Replace heating compartment access panel.

**▲ CAUTION** Some soaps used for leak detection are corrosive to certain metals. Carefully rinse piping thoroughly after leak test has been completed. Do not use matches, candles, flame or other sources of ignition to check for gas leaks.

## Cleaning the Burner Assembly (if needed)

1. Turn off electrical and gas power supplies to furnace. Remove upper and lower furnace access panels.
2. Disconnect the wires from the gas valve.
3. Remove the burner box cover (if equipped).
4. Disconnect the gas supply line from the gas valve. Remove gas valve/manifold assembly.
5. Mark and disconnect sensor wire from the sensor. Disconnect wires from flame rollout switches.
6. Disconnect combustion air intake pipe. It may be necessary to cut the existing pipe to remove burner box assembly.
7. Remove four screws which secure burner box assembly to vest panel. Remove burner box from the unit.
8. Use the soft brush attachment on a vacuum cleaner to gently clean the face of the burners. Visually inspect the inside of the burners and crossovers for any blockage caused by foreign matter. Remove any blockage.
9. Reinstall the burner box assembly using the existing four screws. Make sure that the burners line up in the center of the burner ports.
10. Reconnect the sensor wire and reconnect the 2-pin plug to the ignitor wiring harness. Reconnect wires to flame rollout switches.
11. Reinstall the gas valve manifold assembly. Reconnect the gas supply line to the gas valve. Reinstall the burner box cover.
12. Reconnect wires to gas valve.
13. Replace the blower compartment access panel.
14. Refer to instruction on verifying gas and electrical connections when re-establishing supplies.
15. Follow lighting instructions to light and operate furnace for 5 minutes to ensure that heat exchanger is clean and dry and that furnace is operating properly.
16. Replace heating compartment access panel.

# Service Information

## LOW GWP APPLICATION

### **⚠ WARNING**

For use with GE Appliances approved evaporator coil and LGWP sensors only. Use original manufacturer recommended LGWP sensors if using non GE Appliances approved evaporator coil.

### Connecting the Furnace Control Board Sensor.

See Figure 64 and follow steps below:

1. Route sensor wire #1 through provided grommet. Form a drip loop below the control board on upflow installations to prevent condensate dripping on the control board.

2. Avoid sharp edges when routing sensor wire during installation.

3. Sensor wire must not block view of 7 segment LED .

Ensure the cable is properly seated into the SENSOR 1 plug (LGWP1). The Molex plug clip should lock into the Molex connection point for a secured connection, as shown below in **Figure 65**. Verify the connection is free of dust, debris, and moisture.

**NOTE:** In confined space applications, connect the second sensor to the SENSOR 2 plug (LGWP2). Refer to evaporator coil installation instructions for more detail.

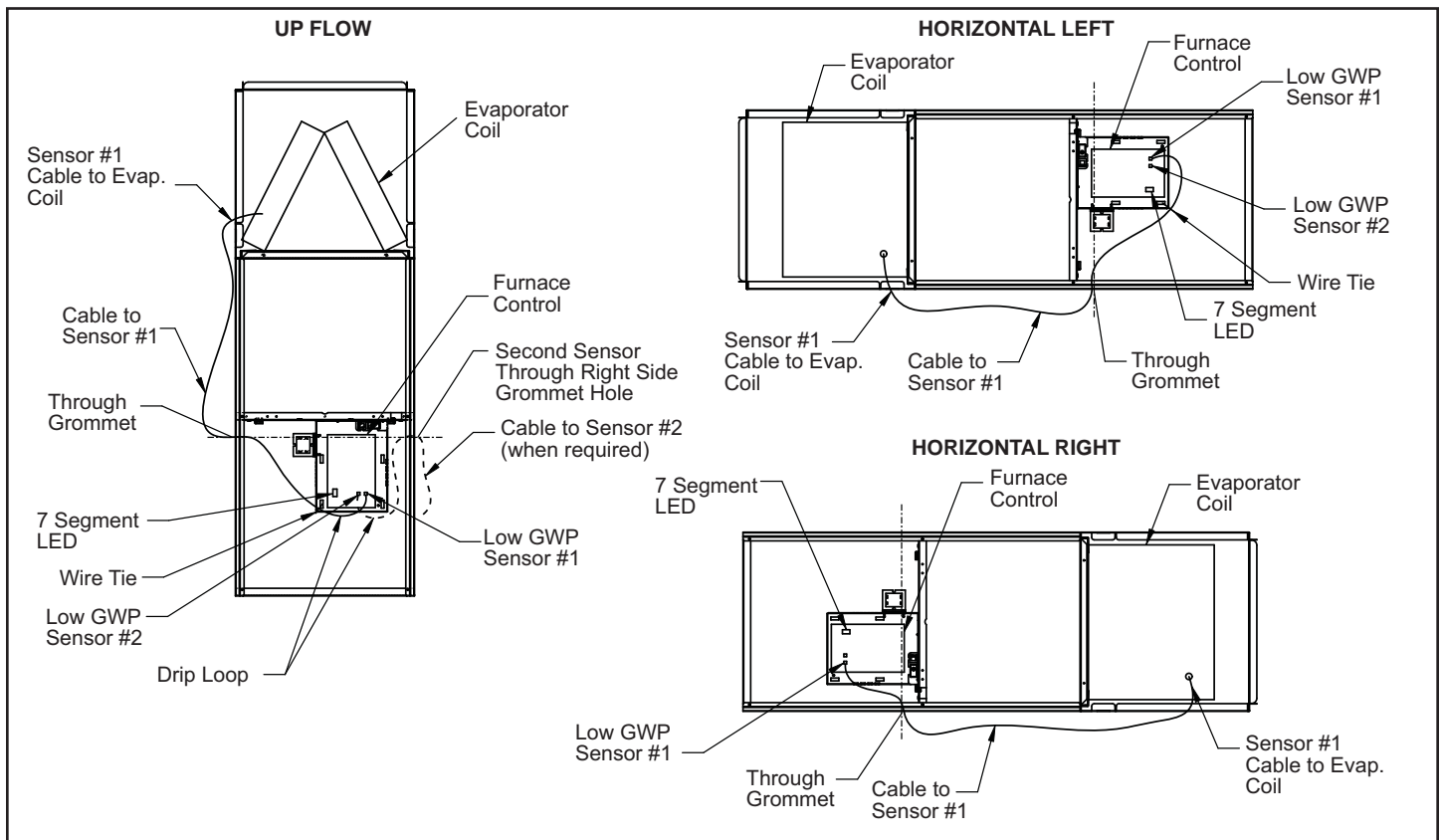


Figure 64.



Figure 65. Single Stage Constant Torque Control

# Service Information

## Low GWP Dip Switch Settings

Adjust the DIP switch settings to the sensor configuration. Failure to do so will cause faults on power-up. See **Figure 66** and **Table 22**.



Figure 66.

Table 22. DIP Switch Settings

Configuration	Switch 1	Switch 2
One (1) sensor, connected to SENSOR 1 plug	OFF (enable)	ON (disable)
Two (2) sensors, connected to SENSOR 1 plug and SENSOR 2 plug	OFF (enable)	OFF (enable)

In single sensor configurations, the sensor must be connected to the SENSOR 1 plug (LGWP1). Configurations other than the ones shown in **Table 22** will cause a servicing fault.

Each DIP switch corresponds to a sensor position (i.e., DIP switch 1 to sensor 1; DIP switch 2 to sensor 2). The default factory switch positions are set to OFF (ENABLED)

The furnace control board software reads the OFF position as an active sensor. A sensor should be present for the corresponding sensor connector. Setting the DIP switch to ON disables the sensor position.

## Secondary Sensor Requirements

### Additional Line Sets

If additional refrigerant line joints are present outside of the line set sleeve and a secondary refrigerant detection sensor is required, its installation must comply with the requirements listed in Refrigerant Detection Sensor Kit (27V53). See **Figure 66** for routing the secondary sensor cable through the furnace cabinet.

## Non-Low GWP Applications

**⚠ WARNING** For Furnace only applications or Furnace replacement in a Non-Low GWP applications, the LOW GWP sensors should be disabled, otherwise the blower will operate continuously. To do this, the Low GWP Dip switches setting for both – Sensor 1 and the Sensor 2 must be moved to the ON position.

## Furnace Control Board Low GWP Modes of Operation

The modes of operation for the furnace control board are Initializing, Normal, Leak Detected, and Fault.

### Initializing

The furnace control board is establishing connection with the refrigerant detection sensor and is completing an initial five-minute purge sequence.

### Normal

The HVAC system is functioning normally. The furnace control board has not detected a refrigerant leak.

### Leak Detected

When the furnace control board detects a refrigerant leak:

1. The furnace control board shuts off the (R) input (24VAC power) to the thermostat, which de-energizes the outdoor unit compressor and heat sources, such as gas and/or electric strip heat. No heating or cooling demands will be met.
2. The furnace control board activates the blower (high speed). The blower purges refrigerant from the cabinet, plenum, and ductwork.
3. After the furnace control board determines the refrigerant levels are below the safety threshold, the blower will continue to operate for the remainder of the seven (7) -minute cycle.
4. After the blower sequence is complete, the HVAC system resumes normal operation.

**NOTE:** The HVAC system may not maintain a cooling or heating setpoint if a significant leak exists. Any refrigerant leaks that remain unaddressed for an extended time may cause the HVAC system to shut down on a low refrigerant pressure limit condition.

### Fault

When a Low GWP fault is detected by the furnace control board, the indoor unit blower engages and remains engaged at a constant air flow output until the fault is cleared.

**NOTE:** See **Table 4** "Ignition control diagnostic codes".

# Service Information

## LGWP Test Button Functionality

The furnace control board is equipped with a **Test/Reset** push button. The Test button can be used to perform several functions, depending on the mode of operation of the furnace control board.

**Table 23** lists the functions of the Test button during each mode of operation.

**Table 23. LGWP Test Button Function**

Mode of Operation	Press the Test Button to:
Normal	Trigger a leak detection response. Verify all equipment is wired correctly into the furnace blower control board (after installation).
Leak Detected	Reset the furnace control board to a normal mode of operation after a previous leak has been detected and purged from the HVAC system.
Fault	Reset the furnace control board after troubleshooting and resolving a fault condition. If the fault is not resolved, the furnace control board will enter the Fault mode again.

## LGWP Test Button - Additional Functions

**Table 24** lists the additional functions of the Test Button while the furnace control board is functioning within the states of Initializing, Monitoring, Leak Detection, Servicing and Fault.

**Table 24. Additional Button Functions**

State	Press	Action
Initializing	Short	Skips remaining pre-purge after sensors are recognized by the furnace control board
Initializing	Long	Reset control
Monitoring	Short	Clear purge-counter if prior mitigation has occurred; Test mitigation
Monitoring	Long	Reset control
Mitigating	Short	If testing mitigation, end test
Servicing	Short	Reevaluate fault condition - if cleared return to monitoring, otherwise update indicator
Servicing	Long	Reset control
Fault	Short	Reevaluate fault condition - if cleared return to monitoring, otherwise update indicator
Fault	Long	Reset control

## External Alarm

(For applications with external alarms wired directly to the furnace control board)

The furnace control board triggers the external alarm system when it enters Leak Detected mode. For alarm notifications, the furnace control board provides a dry relay contact that is rated 3A at 30 VAC/DC.

## THERMOSTAT COMPATIBILITY

Thermostats that preserve memory settings are compatible with the furnace control board. Examples include:

- Battery-powered thermostats
- Analog Thermostat
- Late-model programmable thermostats

NOTE: Early-generation digital and programmable thermostats may not retain the operation mode and temperature setpoints after a power outage.

The following scenarios are likely to occur when home occupants are not available to adjust the thermostat setpoints as the system is recovering from leak detection and resuming normal operation:

- Heating could be lost during a cold night
- Cooling could be lost during a hot day
- The thermostat could reset to an incorrect temperature setpoint

## START UP PROCEDURE

The furnace control board is equipped with a **LGWP Test/Reset** button, see Test Button Functionality. After the furnace control board has been mounted and wired, restore power to the HVAC system. The system will then run through a purge sequence for five minutes. After the purge sequence is complete, proceed to testing cooling demand and heating demand.

### Cooling Demand

1. Prompt a cooling demand at the thermostat.
2. Press the LGWP Test button on the furnace control board. The system then executes a leak detection response.
3. Observe the following sequence:
  - a. The LED indicator for leak detection. See **Table 4** "Ignition control diagnostic codes".
  - b. The blower powers up.
  - c. The outdoor compressor powers down.
4. Press the **LGWP Test** button to terminate the simulated Leak Detected mode upon test completion

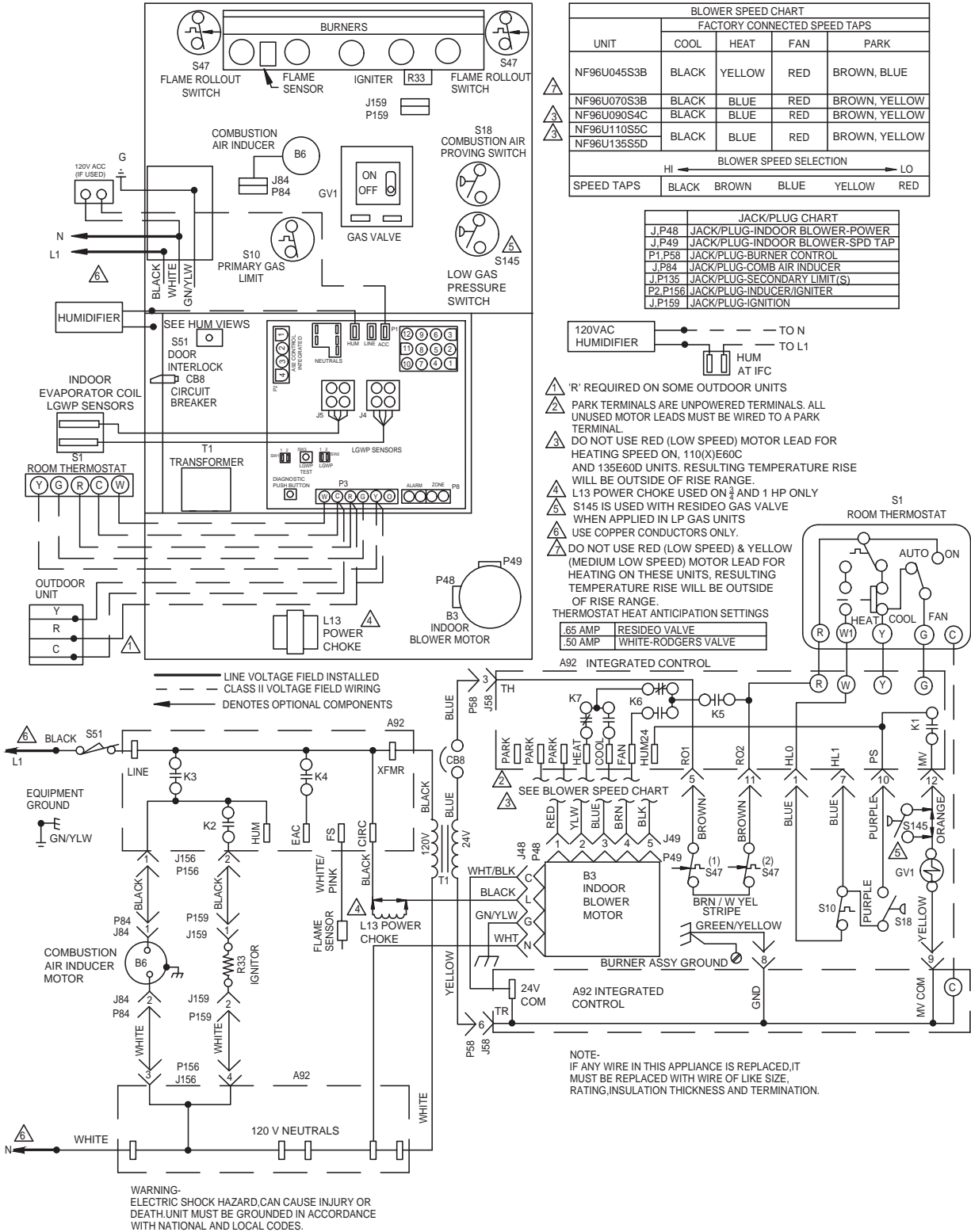
### Heating Demand

1. Prompt a heating demand at the thermostat.
2. Press the LGWP Test button on the furnace control board. The system then executes a leak detection response.
3. Observe the following sequence:
  - a. The LED indicator for leak detection. See **Table 4** "Ignition control diagnostic codes".
  - b. The blower powers up.
  - c. The gas burners power down.
  - d. The outdoor compressor powers down.
4. Press the **LGWP Test** button to terminate the simulated Leak Detected mode upon test completion.

The installation of the furnace control board is complete after both sequences are successfully completed.

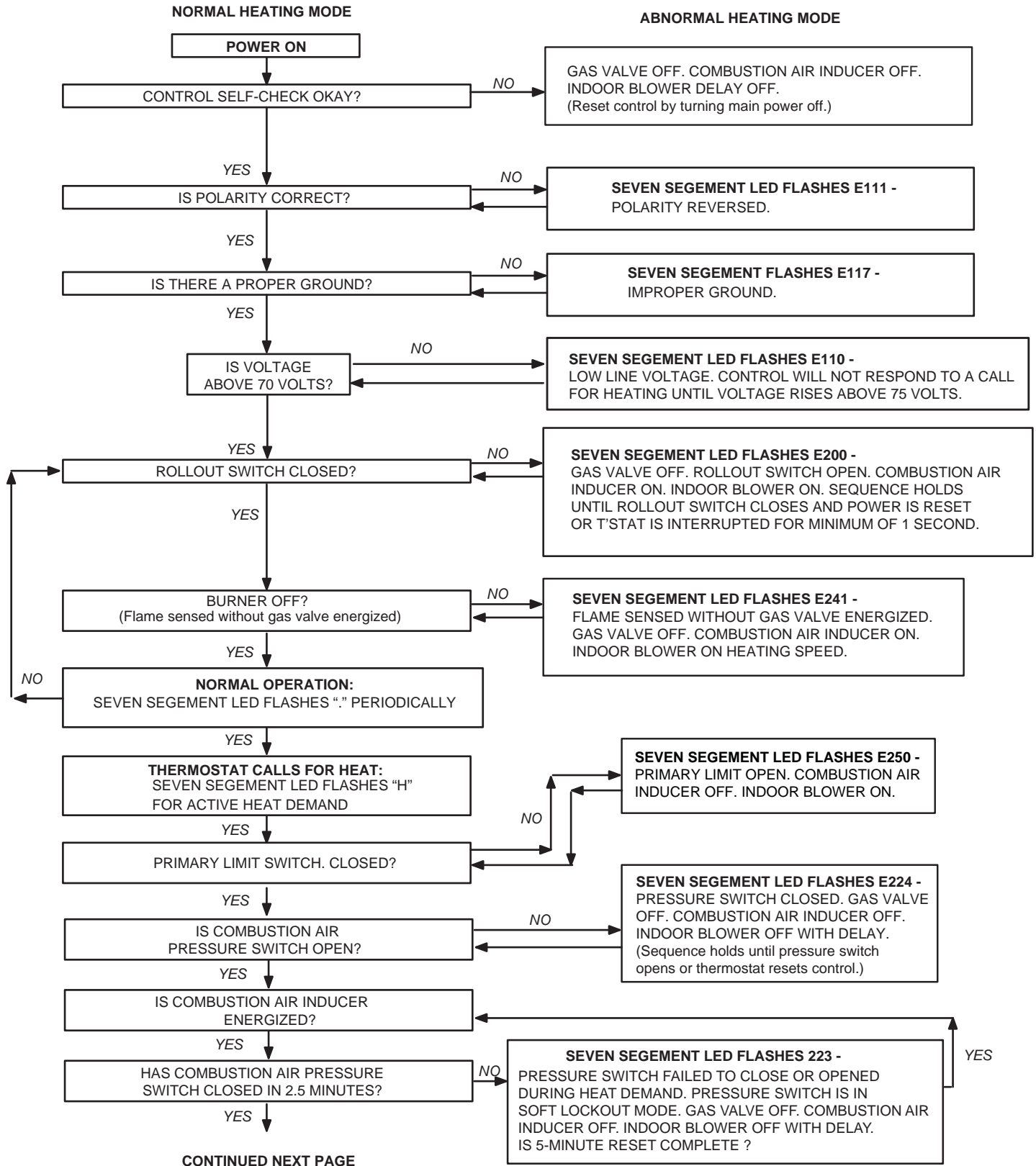
# Service Information

## WIRING DIAGRAM AND SEQUENCE OF OPERATION



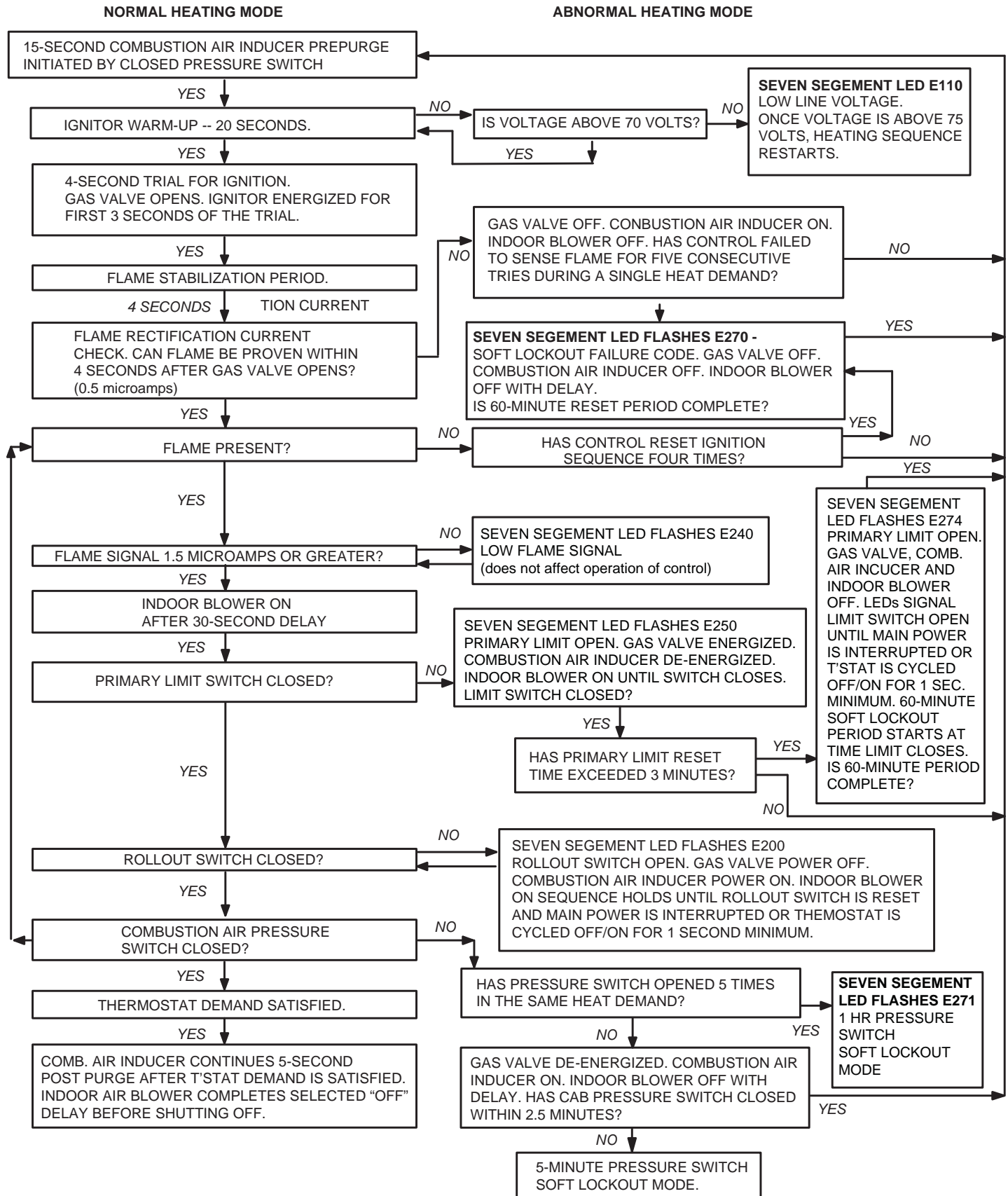
# Service Information

## TROUBLESHOOTING - Heating Sequence of Operation



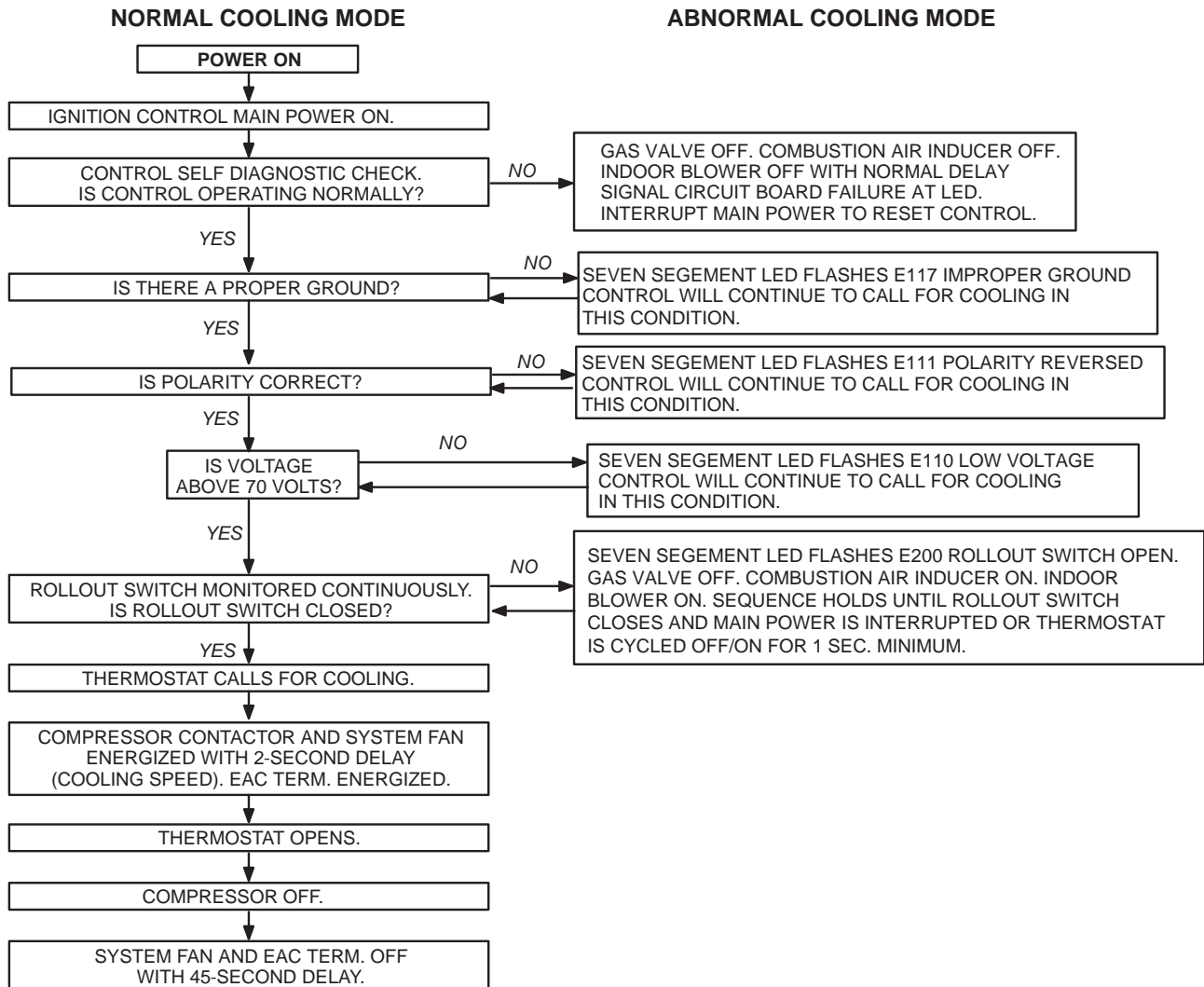
# Service Information

## TROUBLESHOOTING - Heating Sequence of Operation (cont)

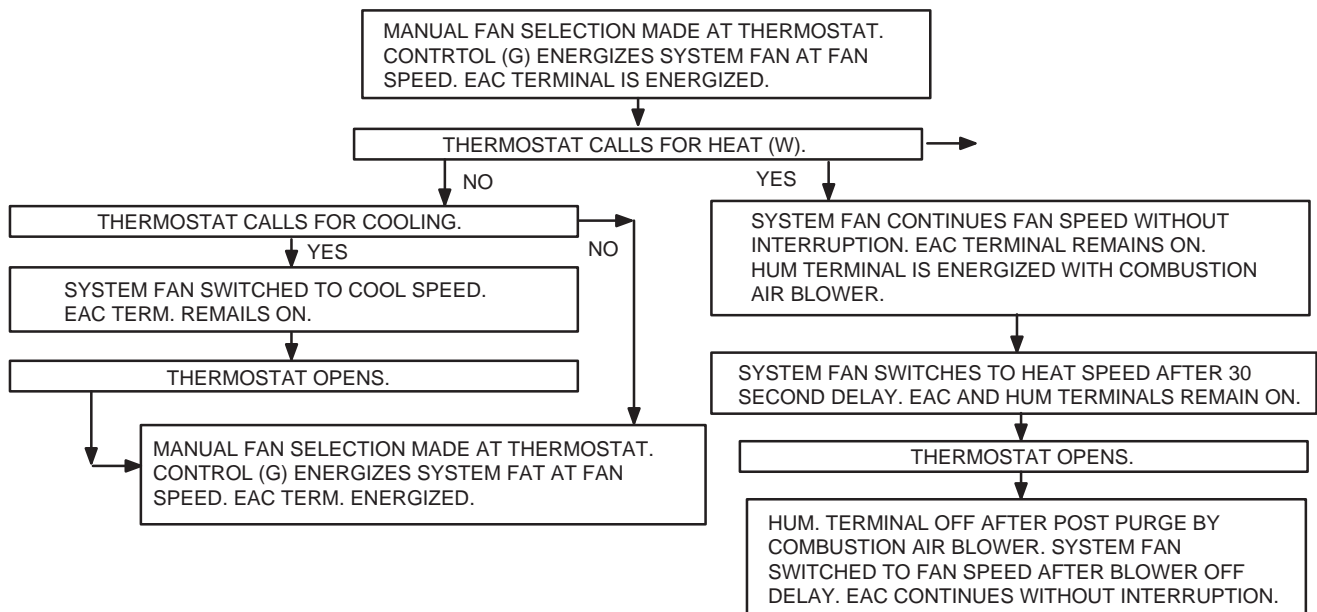


# Service Information

## TROUBLESHOOTING - Cooling Sequence of Operation



## Continuous Fan Sequence Of Operationmanual





**GE APPLIANCES**

All specifications and illustrations subject to change without notice and without incurring obligations.

Printed in the U.S.A.