



# Z1203-ND4

## ADJUSTABLE HORIZONTAL BACK TO BACK SIPHON JET-NO HUB

SPECIFICATION SHEET

TAG \_\_\_\_\_

Dimensional Data (inches and [ mm ]) are Subject to Manufacturing Tolerances and Change Without Notice

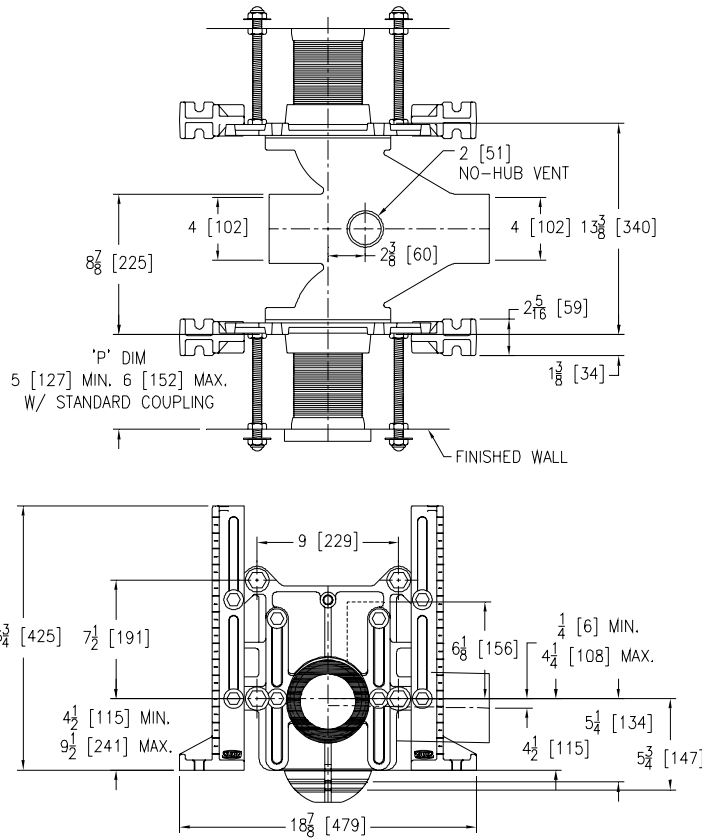

Product Number	Approx. Wt. Lbs. [kg]
Z1203-ND4	120[51]

Note:

1. Min. 'P' Dim. Obtainable=2 [51]
2. Feet bolted to floor using min. 1/2 [13] dia. bolts and back slots on carrier feet.

**ENGINEERING SPECIFICATION: ZURN Z1203-ND4**

Adjustable, horizontal siphon jet water closet "Rigid System" with 4 [102] No-Hub connections. Complete with Dura-Coated cast iron fitting, with 2 [51] vent, adjustable gasketed face plates, universal floor mounted foot supports, corrosion resistant adjustable ABS couplings with integral test cap, fixture bolts, trim, stud protectors and bonded "Neo-Seal" gaskets.

**OPTIONS** (Check/specify appropriate options)

**Z1203-ND4** 4 [102] No-Hub Back to Back Inlet (Double)

**PREFIXES**

- \_\_\_ Z D.C.C.I. System with Zurn "ZZ" Adjustable Coupling\*
- \_\_\_ ZQ D.C.C.I. System with Non-Adjustable Coupling

**SUFFIXES**

- |  |  |
|--|--|
| <ul style="list-style-type: none"> <li>___ -A Auxiliary Support Assembly (For P-Dim. Greater than 18 [457])</li> <li>___ -B Blowout Type Fixture Support</li> <li>___ -BC Back Cleanout</li> <li>___ -CC Corrosion Resistant Cast Iron Coupling (6 to 12 [152] to [305])</li> <li>___ -CL Coupling Length Greater than 12 [152] (Specify Length Required.)</li> <li>___ -F Floor Mount, Back Outlet Fixture Support</li> <li>___ -G Galvanized Cast Iron</li> <li>___ -JC 2 [51] Auxiliary Inlet with Sanitary Sweep on Faceplate Centerline (No-Hub only)</li> <li>___ -M Auxiliary Foot Support (For P-Dim. 10-18 [254-457])</li> <li>___ -T Threaded Connection (Available on Restricted Basis Only)</li> <li>___ -VP Vandal-Proof Trim</li> <li>___ -W Adapter for Women's Urinal</li> </ul> | <ul style="list-style-type: none"> <li>___ -XB Bariatric 1000 lb [454 kg] Carrier</li> <li>___ -XH Extra-Heavy-Duty 750 lb [340 kg] Carrier</li> <li>___ -X3 3 [76] Foot Extension</li> <li>___ -X4 4 [102] Foot Extension</li> <li>___ -29 Mechanical Test Cap Assembly (Previously Z1210-29)</li> <li>___ -45 Finishing Frame for Siphon Jet System (For Blowout System Specify -45-B) (Previously Z1210-45)</li> <li>___ -50 Flush Valve Supply Support for W.C. (Previously Z1210-50)</li> <li>___ -61 "ZZ" Coupling Wrench</li> </ul> |
|--|--|

\*REGULARLY FURNISHED UNLESS OTHERWISE SPECIFIED

<b>REV. G</b>	<b>DATE: 9/25/08</b>	<b>C.N. NO. 99142</b>
<b>DWG. NO. 54354</b>	<b>PRODUCT NO. Z1203-ND4</b>	